

LNB2306ELT1G

N-Channel 30V (D-S) MOSFET , ESD Protected

1. FEATURES

- $R_{DS(ON)} \leq 40m\Omega @ V_{GS} = 10V$
- $R_{DS(ON)} \leq 60m\Omega @ V_{GS} = 4.5V$
- ESD Protected.
- Super high density cell design for extremely low $R_{DS(ON)}$.
- Exceptional on-resistance and maximum DC current capability.
- We declare that the material of product compliance with RoHS requirements and Halogen Free.



2. APPLICATIONS

- Power Management in Note book
- Portable Equipment
- Load Switch

3. DEVICE MARKING AND ORDERING INFORMATION

Device	Marking	Shipping
LNB2306ELT1G	23	3000/Tape&Reel

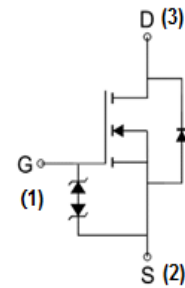

4. MAXIMUM RATINGS($T_a = 25^\circ C$)

Parameter	Symbol	Limits	Unit	
Drain–Source Voltage	VDS	30	V	
Gate–to–Source Voltage	VGSS	± 20	V	
Continuous Drain(Note 1)	ID	TA =25°C	5.3	A
		TA =70°C	4.2	
Pulsed Drain Current	IDM	21.2		
Maximum Power Dissipation(Note 1)	PD	TA =25°C	1.39	W
		TA =70°C	0.89	
Operating Junction Temperature	TJ	-55 ~150	°C	
Storage Temperature Range	Tstg	-55 ~150		
Thermal Resistance-Junction to Ambient(Note 1)	RθJA	90	°C/W	

1.The device mounted on 1in² FR4 board with 2 oz copper

5. ELECTRICAL CHARACTERISTICS (Ta= 25°C)

Characteristic	Symbol	Min.	Typ.	Max.	Unit
STATIC					
Gate Threshold Voltage (VDS =VGS , ID =250μA)	VGS(th)	1	1.5	3	Vdc
Gate Leakage Current (VDS =0V, VGS =±16V)	IGSS	-	-	±10	μA _{dc}
Zero Gate Voltage Drain Current (VDS =30V, VGS =0V)	IDSS	-	-	1	
Drain-Source On-Resistance (VGS =10V, ID = 6.7A)	RDS(ON)	-	35	40.0	mΩ
Drain-Source On-Resistance (VGS =4.5V, ID = 5.0A)		-	48	60.0	
Diode Forward Voltage (IS =1.7A, VGS =0V)	VSD	-	0.8	1.2	Vdc
DYNAMIC					
Input Capacitance	(VDS =15V, VGS =0V, f=1MHz)	Ciss	-	370	pF
Output Capacitance		Coss	-	68	
Reverse Transfer Capacitance		Crss	-	21	
Gate Resistance (f=1MHz)	Rg	-	1.9	-	mΩ
Total Gate Charge (VDS =15V, VGS =10V, ID =6.7A)	Qg	-	12	-	nC
Total Gate Charge	(VDS =15V, VGS =4.5V, ID =6.7A)	Qg	-	5.7	
Gate-Source Charge		Qgs	-	3	
Gate-Drain Charge		Qgd	-	2.1	
Turn-On Delay Time	(VDD =15V, RL =15Ω, ID =1.0A, VGEN =10V, RG =6Ω)	td(on)	-	9.2	ns
Turn-On Rise Time		tr	-	13	
Turn-Off Delay Time		td(off)	-	33	
Turn-Off Fall Time		tf	-	3.7	

2. Pulse test: pulse width ≤ 300μs, duty cycle ≤ 2%, Guaranteed by design, not subject to production testing.

6. ELECTRICAL CHARACTERISTICS CURVES

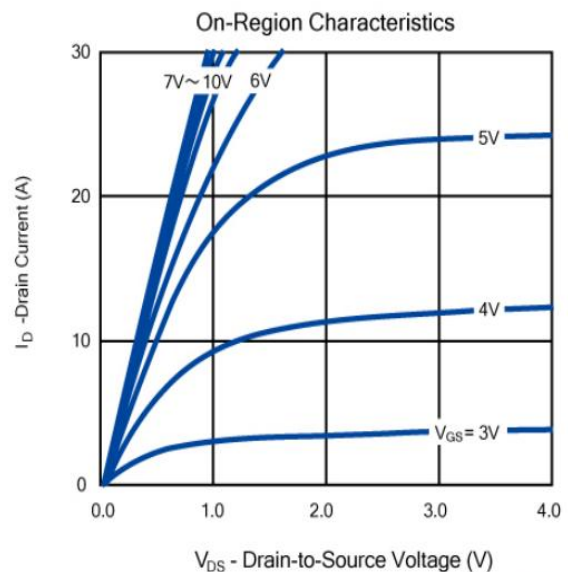
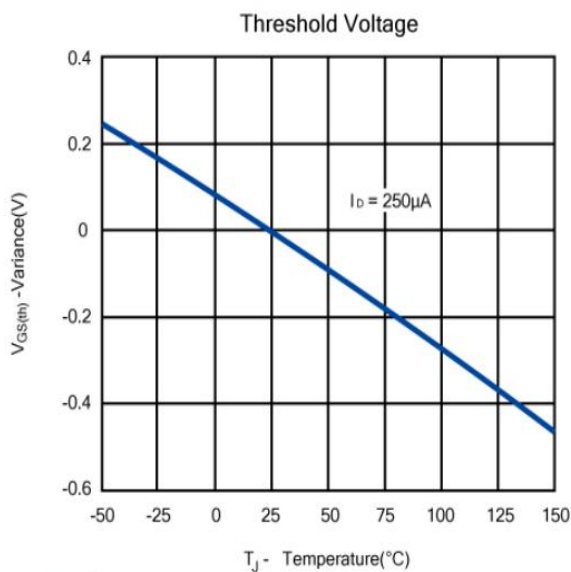
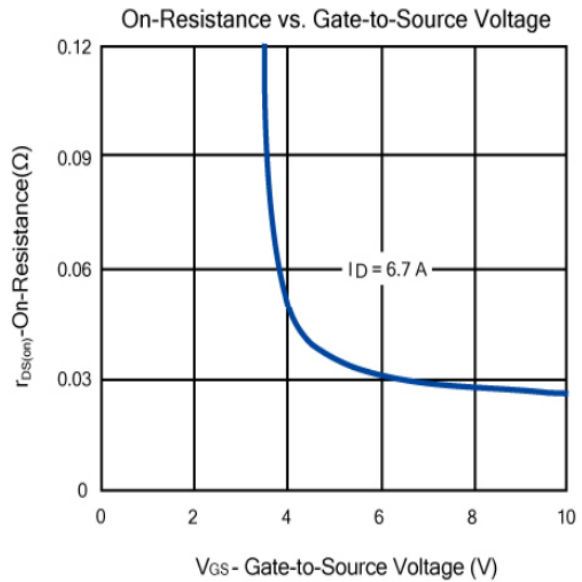
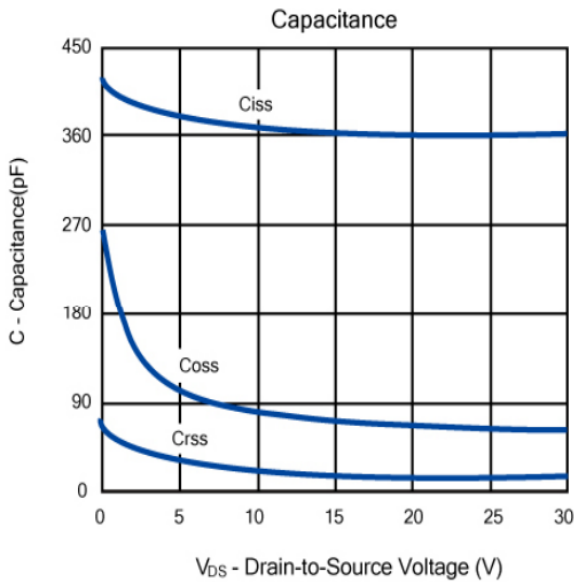
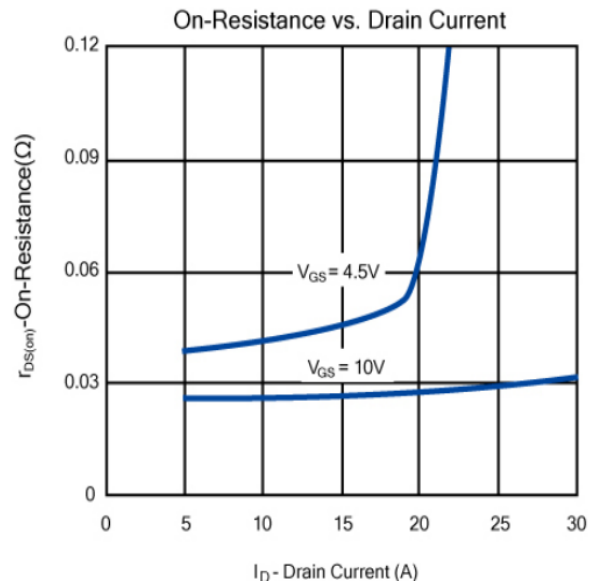
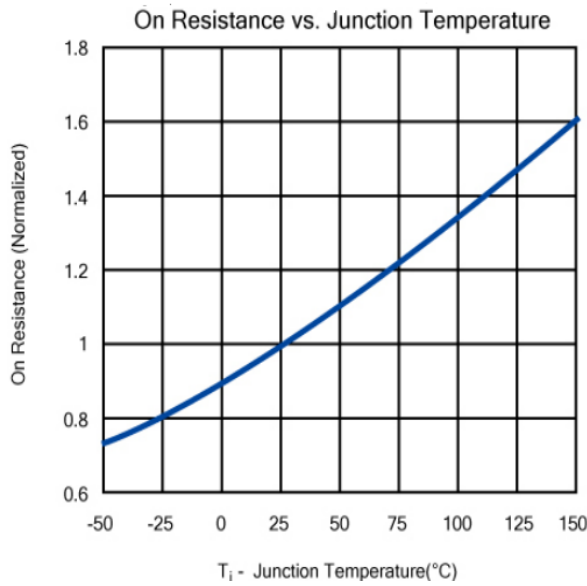

6. ELECTRICAL CHARACTERISTICS CURVES(Con.)

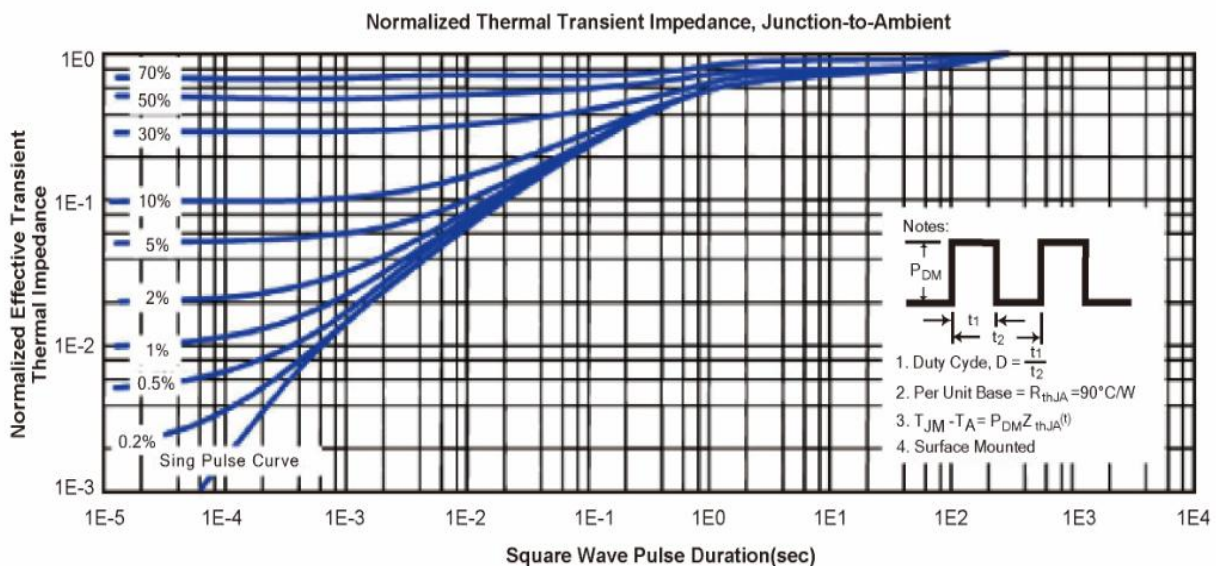
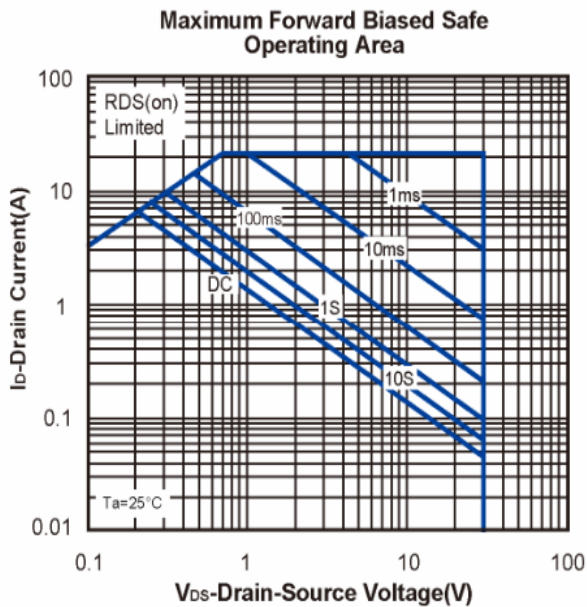
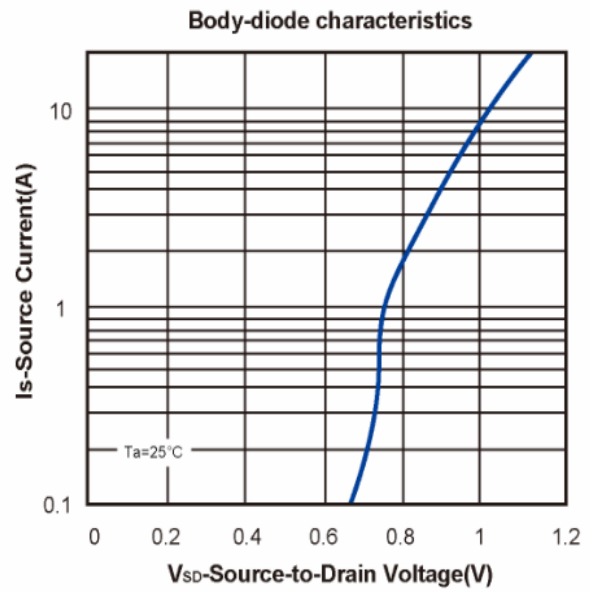
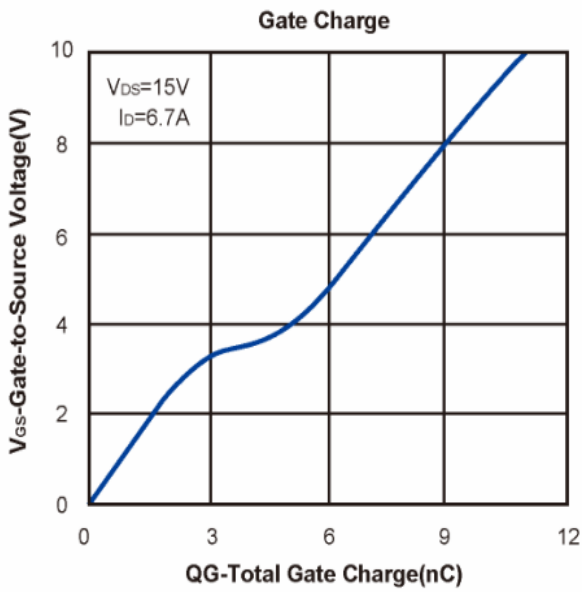

7.OUTLINE AND DIMENSIONS

SOT23-LC

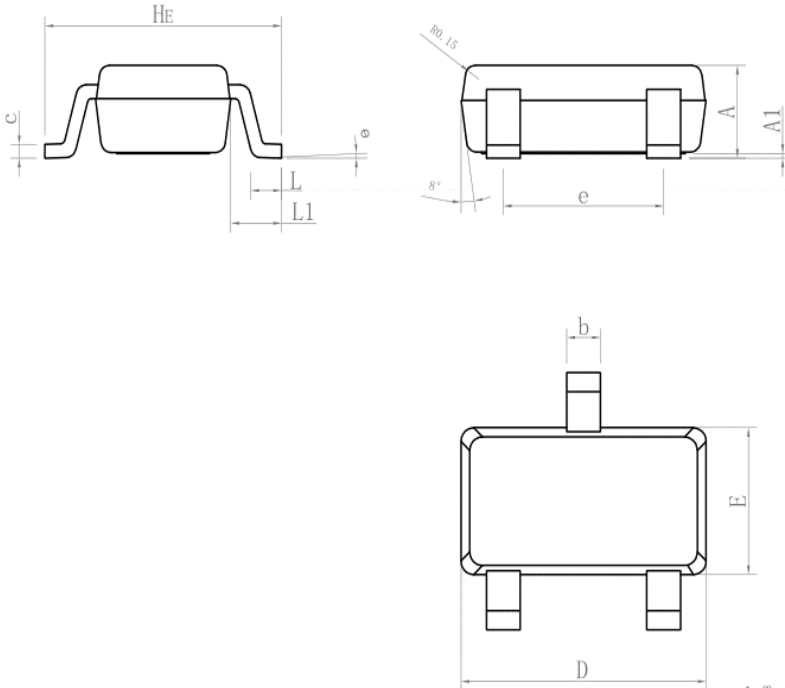

SOT23-LC			
DIM	MIN	NOR	MAX
A	0.90	1.00	1.10
A1	0.01	0.06	0.10
b	0.30	0.40	0.50
c	0.10	0.15	0.20
D	2.80	2.90	3.00
E	1.50	1.60	1.70
e	1.80	1.90	2.00
L	0.20	0.40	0.60
L1	0.45	0.60	0.75
HE	2.60	2.80	3.00
θ	0°	-	10°

GENERAL NOTES

1. Top package surface finish Ra0.4±0.2um
2. Bottom package surface finish Ra0.7±0.2um
3. Side package surface finish Ra0.4±0.2um

8.SOLDERING FOOTPRINT

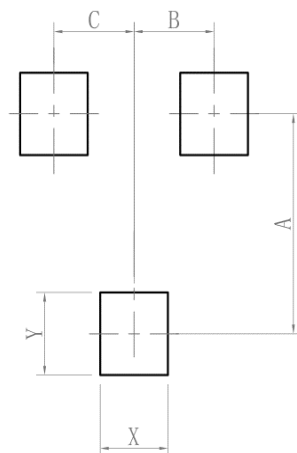

SOT23-LC	
DIM	(mm)
X	0.80
Y	0.90
A	2.40
B	0.95
C	0.95