

Transient Voltage Suppressors

P6KE Series

Transient Voltage Suppressors - P6KE Series

Features

- Fast response time
- Low incremental surge resistance
- Matte tin lead-free Plated
- Halogen free and RoHS compliant
- Typical IR less than 1μA above 12V
- Compatible with industrial standard package DO-15
- For surface mounted applications to optimize board space
- ESD protection of data lines in accordance with IEC 61000-4-2 (IEC801-2)
- EFT protection of data lines in accordance with IEC 61000-4-4 (IEC801-4)
- 600W peak pulse power capability with at 10/1000μs waveform, repetition rate (duty cycle): 0.01%
- High temperature soldering guaranteed: 260°C/40 seconds

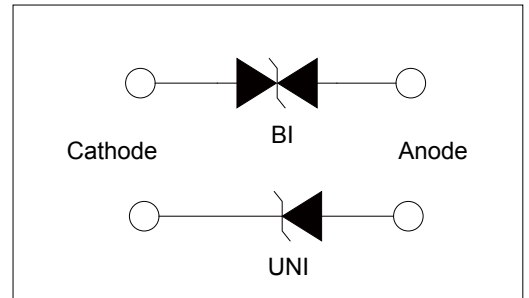
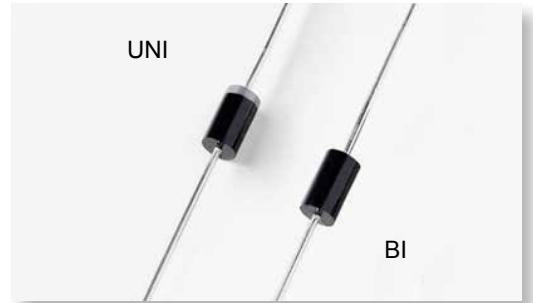

Description

The P6KE series is designed specifically to protect sensitive electronic equipment from voltage transients induced by lightning and other transient voltage events.

Mechanical Characteristics

Rating	Symbol	Value	Units
Peak Pulse Power Dissipation by 10x1000μs test waveform (Note 1)	P_{PPM}	600	Watts
Steady State Power Dissipation on infinite heat sink at $T_L=75^\circ\text{C}$	P_D	5	Watts
Peak Forward Surge Current, 8.3ms Single Half Sine Wave Unidirectional only (Note 2)	I_{FSM}	100	Amps
Maximum Instantaneous Forward Voltage at 25A for Unidirectional only (Note 3)	V_F	3.5/5.0	V
Operating junction and Storage Temperature Range	T_J, T_{STG}	-55°C to 175°C	°C
Typical Thermal Resistance Junction to Lead	$R_{\theta JL}$	20	°C/W
Typical Thermal Resistance Junction to Ambient	$R_{\theta JA}$	75	°C/W

Notes:

1. Non-repetitive current pulse, per Fig. 3 and derated above $T_A = 25^\circ\text{C}$ per Fig. 2.
2. Measured on 8.3ms single half sine wave or equivalent square wave, duty cycle=4 per minute maximum.
- 3.3. $V_F < 3.5\text{V}$ for devices of $V_{BR} \leq 200\text{V}$ and $V_F < 5.0\text{V}$ for devices of $V_{BR} \geq 201\text{V}$

Transient Voltage Suppressors - P6KE Series

Electrical Characteristics

Type Number		Reverse Stand-Off Voltage V _R (V)	Breakdown Voltage@I _T		Test Current I _T (mA)	Maximum Clamping Voltage@I _{PP} V _C (V)	Peak Pulse Current I _{PP} (A)	Reverse Leakage @V _R I _R (μA)
(UNI)	(BI)		V _{BR} MIN.(V)	V _{BR} MAX.(V)				
P6KE6.8A	P6KE6.8CA	5.80	6.45	7.14	10	10.5	58.1	1000
P6KE7.5A	P6KE7.5CA	6.40	7.13	7.88	10	11.3	54.0	500
P6KE8.2A	P6KE8.2CA	7.02	7.79	8.61	10	12.1	50.4	200
P6KE9.1A	P6KE9.1CA	7.78	8.65	9.55	1	13.4	45.5	50
P6KE10A	P6KE10CA	8.55	9.50	10.50	1	14.5	42.1	10
P6KE11A	P6KE11CA	9.40	10.50	11.60	1	15.6	39.1	5
P6KE12A	P6KE12CA	10.20	11.40	12.60	1	16.7	36.5	5
P6KE13A	P6KE13CA	11.10	12.40	13.70	1	18.2	33.5	1
P6KE15A	P6KE15CA	12.80	14.30	15.80	1	21.2	28.8	1
P6KE16A	P6KE16CA	13.60	15.20	16.80	1	22.5	27.1	1
P6KE18A	P6KE18CA	15.30	17.10	18.90	1	25.2	24.2	1
P6KE20A	P6KE20CA	17.10	19.00	21.00	1	27.7	22.0	1
P6KE22A	P6KE22CA	18.80	20.90	23.10	1	30.6	19.9	1
P6KE24A	P6KE24CA	20.50	22.80	25.20	1	33.2	18.4	1
P6KE27A	P6KE27CA	23.10	25.70	28.40	1	37.5	16.3	1
P6KE30A	P6KE30CA	25.60	28.50	31.50	1	41.4	14.7	1
P6KE33A	P6KE33CA	28.20	31.40	34.70	1	45.7	13.3	1
P6KE36A	P6KE36CA	30.80	34.20	37.80	1	49.9	12.2	1
P6KE39A	P6KE39CA	33.30	37.10	41.00	1	53.9	11.3	1
P6KE43A	P6KE43CA	36.80	40.90	45.20	1	59.3	10.3	1
P6KE47A	P6KE47CA	40.20	44.70	49.40	1	64.8	9.4	1
P6KE51A	P6KE51CA	43.60	48.50	53.60	1	70.1	8.7	1
P6KE56A	P6KE56CA	47.80	53.20	58.80	1	77.0	7.9	1
P6KE62A	P6KE62CA	53.00	58.90	65.10	1	85.0	7.2	1
P6KE68A	P6KE68CA	58.10	64.60	71.40	1	92.0	6.6	1
P6KE75A	P6KE75CA	64.10	71.30	78.80	1	103.0	5.9	1
P6KE82A	P6KE82CA	70.10	77.90	86.10	1	113.0	5.4	1
P6KE91A	P6KE91CA	77.80	86.50	95.50	1	125.0	4.9	1
P6KE100A	P6KE100CA	85.50	95.00	105.00	1	137.0	4.5	1
P6KE110A	P6KE110CA	94.00	105.00	116.00	1	152.0	4.0	1
P6KE120A	P6KE120CA	102.00	114.00	126.00	1	165.0	3.7	1
P6KE130A	P6KE130CA	111.00	124.00	137.00	1	179.0	3.4	1
P6KE150A	P6KE150CA	128.00	143.00	158.00	1	207.0	2.9	1
P6KE160A	P6KE160CA	136.00	152.00	168.00	1	219.0	2.8	1
P6KE170A	P6KE170CA	145.00	162.00	179.00	1	234.0	2.6	1
P6KE180A	P6KE180CA	154.00	171.00	189.00	1	246.0	2.5	1
P6KE200A	P6KE200CA	171.00	190.00	210.00	1	274.0	2.2	1
P6KE220A	P6KE220CA	185.00	209.00	231.00	1	328.0	1.9	1
P6KE250A	P6KE250CA	214.00	237.00	263.00	1	344.0	1.8	1
P6KE300A	P6KE300CA	256.00	285.00	315.00	1	414.0	1.5	1
P6KE350A	P6KE350CA	300.00	332.00	368.00	1	482.0	1.3	1
P6KE400A	P6KE400CA	342.00	380.00	420.00	1	548.0	1.1	1
P6KE440A	P6KE440CA	376.00	418.00	462.00	1	602.0	1.0	1
P6KE480A	P6KE480CA	408.00	456.00	504.00	1	658.0	0.9	1

For bidirectional type having VR of 10 volts and less, the IR limit is double.

Transient Voltage Suppressors - P6KE Series

I-V Curve Characteristics

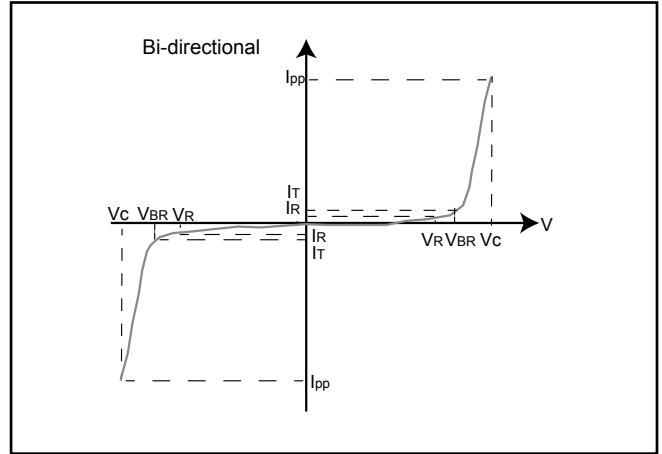
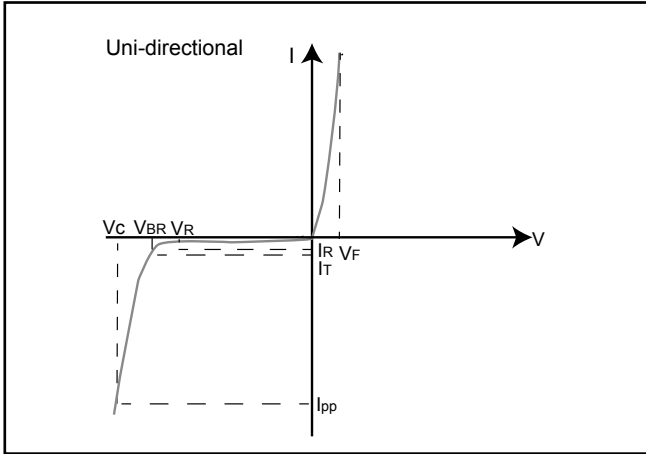

- P_{PPM} Peak Pulse Power Dissipation-- Max power dissipation
- V_r Stand-off Voltage -- Maximum voltage that can be applied to the TVS without operation
- V_{BR} Breakdown Voltage -- Maximum voltage that flows through the TVS at a specified test current (I_r)
- V_c Clamping Voltage -- Peak voltage measured across the suppressor at a specified I_{ppm} (peak impulse current)
- I_r Reverse Leakage Current -- Current measured at V_r
- V_f Forward Voltage Drop for Uni-directional

Ratings and Characteristic Curves ($T_A=25^\circ C$ unless otherwise noted)

Figure 1 - TVS Transients Clamping Waveform

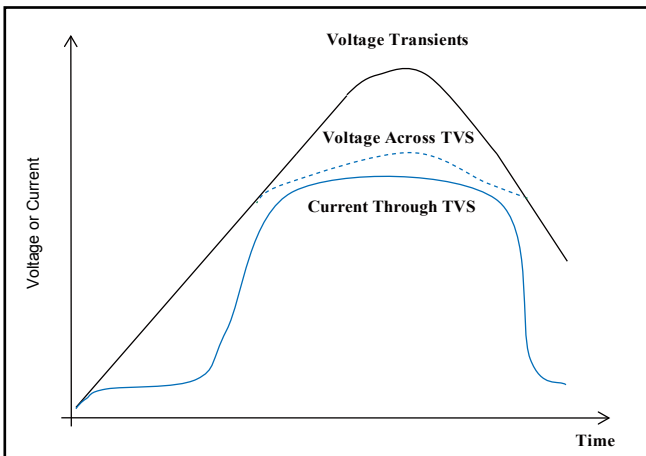
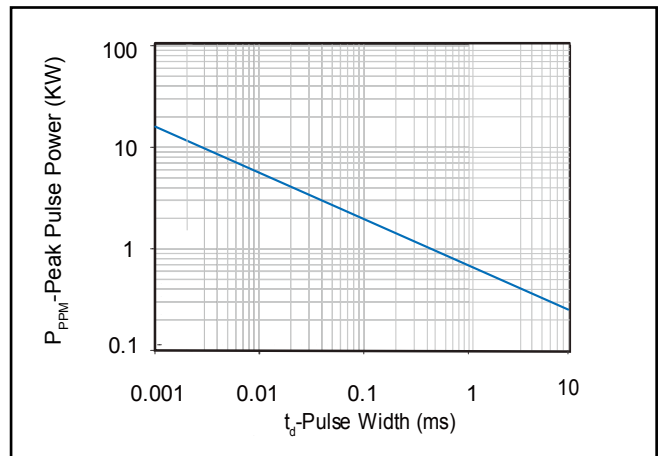

Figure 2 - Peak Pulse Power Rating



Transient Voltage Suppressors - P6KE Series

Ratings and Characteristic Curves (TA=25°C unless otherwise noted)

Figure 3 - Pulse Derating Curve

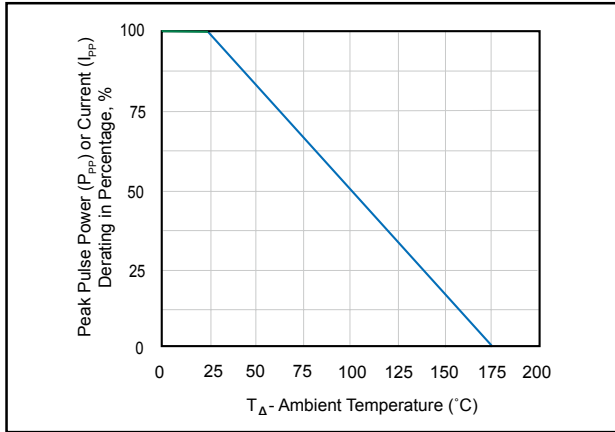

Figure 4 - Pulse Waveform

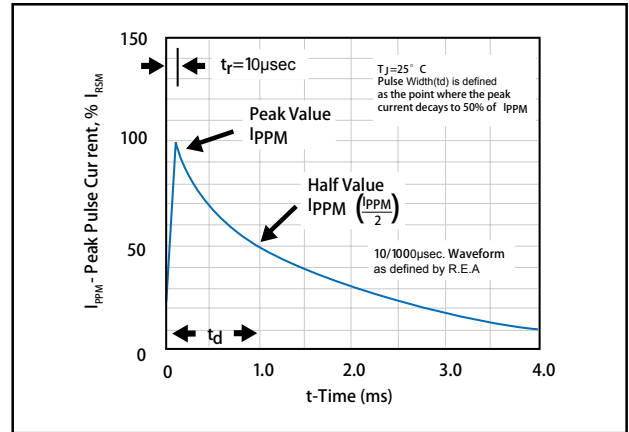

Figure 5 - Typical Junction Capacitance Uni-Directional

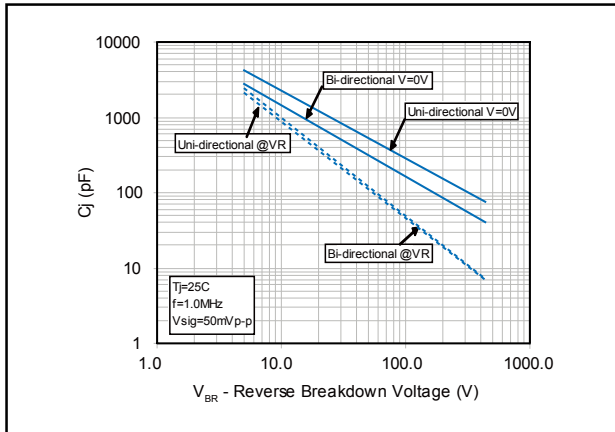

Figure 6 - Steady State Power Derating Curve

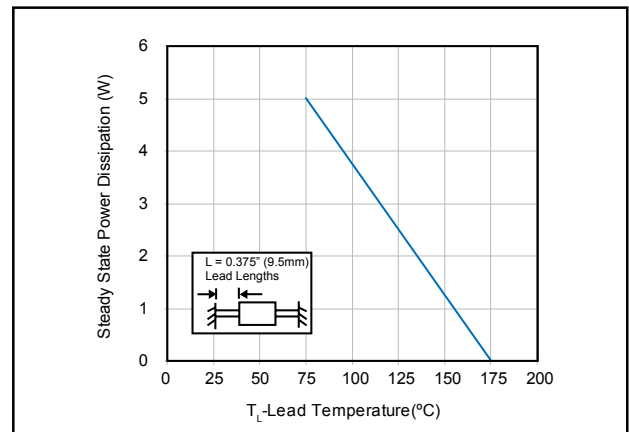
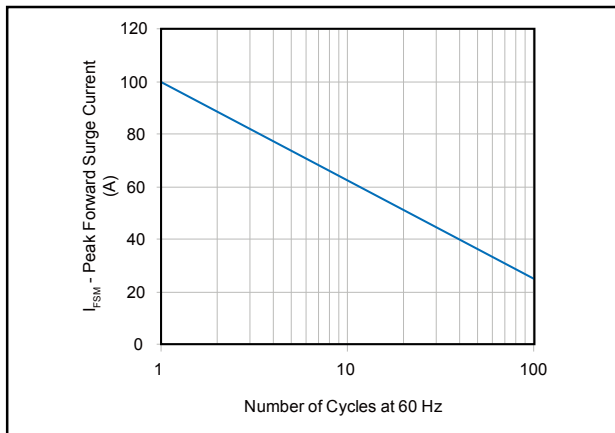

Figure 7 - Maximum Non-Repetitive Forward Surge Current



Transient Voltage Suppressors - P6KE Series

Soldering Parameters

	Reflow Condition	Lead-free assembly
Pre Heat	- Temperature Min ($T_{s(min)}$)	150°C
	- Temperature Max ($T_{s(max)}$)	200°C
	- Time (min to max) (t_s)	60-180 secs
Average ramp up rate (Liquidus Temp (T_L) to peak)		3°C/second max
$T_{s(max)}$ to T_L - Ramp-up Rate		3°C/second max
Reflow	- Temperature (T_L) (Liquidus)	217°C
	- Time (min to max) (t_s)	60-150 seconds
Peak Temperature (T_P)		260+0/-5 °C
Time within 5°C of actual peak Temperature (t_p)		20-40 seconds
Ramp-down Rate		6°C/second max
Time 25°C to peak Temperature (T_P)		8 minutes Max.
Do not exceed		280°C

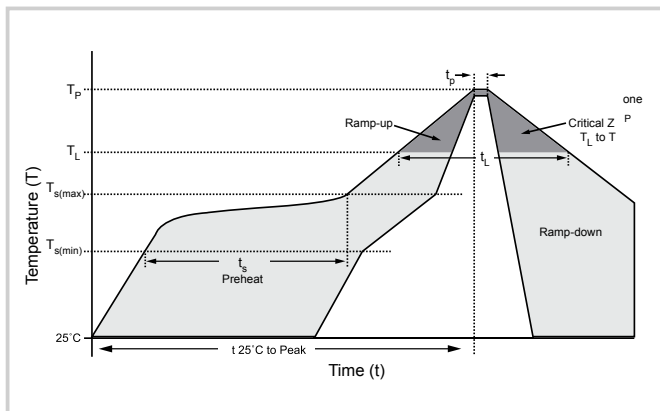

Physical Specifications

Weight	0.045oz., 1.2g
Case	JEDEC DO-15 molded plastic body over passivated junction.
Polarity	Color band denotes the cathode except Bipolar.
Terminals	Matte Tin axial leads, solderable per JESD22-B102D.

Environmental Specifications

Temperature Cycle	JESD22-A104
Pressure Cooker	JESD 22-A102
High Temp. Storage	JESD22-A103
HTRB	JESD22-A108
Thermal Shock	JESD22-A106

Flow/Wave Soldering

Peak Temperature :	265°C
Dipping Time :	10 seconds
Soldering :	1 time

Transient Voltage Suppressors - P6KE Series

Dimensions DO-15

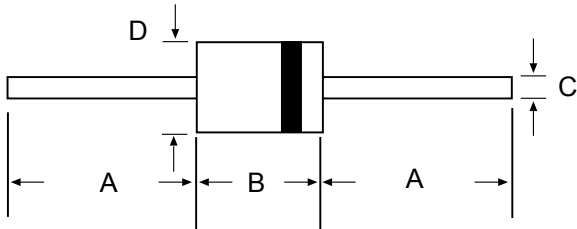

DIM	Inches		Millimeters	
	Min	Max	Min	Max
A	1.000	-	25.40	-
B	0.230	0.300	5.80	7.60
C	0.028	0.034	0.71	0.86
D	0.104	0.140	2.60	3.60

Part Numbering System

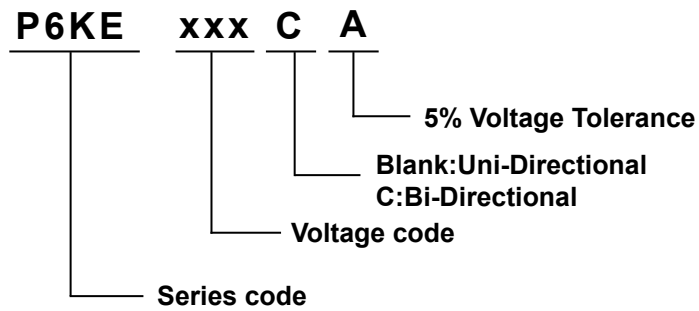

Transient Voltage Suppressors - P6KE Series

Packaging

Part Number	Component Package	Quantity	Packaging Option	Packaging Specification
P6KExxxXX	DO-15	2000	Reel	ELA STD RS-296E

	Symbol	Dimension (mm)
	A	5.0±0.5
	B	53.0±1.0
	Z	1.2Max.
	T	6.0±0.4
	E	0.8Max.
	L1-L2	1.0Max.
	D	250.0±5.0
	C	75.0±5.0
	H	114.0±5.0
Quantity: 2000PCS		

RuiLongYuan Electronics Co., Ltd.

- Reproducing and modifying information of the document is prohibited without permission from Ruilongyuan International Inc.
- Ruilongyuan International Inc. reserves the rights to make changes of the content herein the document anytime without notification. Please refer to our website for the latest document.
- Ruilongyuan International Inc. disclaims any and all liability arising out of the application or use of any product including damages incidentally and consequentially occurred.
- Ruilongyuan International Inc. does not assume any and all implied warranties, including warranties of fitness for particular purpose, non-infringement and merchantability.
- Applications shown on the herein document are examples of standard use and operation. Customers are responsible in comprehending the suitable use in particular applications. Ruilongyuan International Inc. makes no representation or warranty that such applications will be suitable for the specified use without further testing or modification.
- The products shown herein are not designed and authorized for equipments requiring high level of reliability or relating to human life and for any applications concerning life-saving or life-sustaining, such as medical instruments, transportation equipment, aerospace machinery et cetera. Customers using or selling these products for use in such applications do so at their own risk and agree to fully indemnify Ruilongyuan International Inc. for any damages resulting from such improper use or sale.

Tel: +86-755-8290 8296

Fax: +86-755-8290 8002

E-mail: jack@ruilon.com