

Gas Discharge Tube (GDT) Data Sheet

Features

- Provide ultra-fast response to surge voltage from slow-rising surge of 100V/s to rapid-rising surge of 1KV/μs.
- Stable breakdown voltage.
- High insulation resistance.
- Low capacitance (≤1.5pF)
- High holdover voltage
- Large absorbing transient current capability.
- Micro-Gap Design
- Size: 8.0mm*8.0mm
- Storage and operating temperature: -40°C ~ +85°C
- Meets MSL level 1, per J-STD-020
- Safety certification: UL: E327997



Applications

- Repeaters, Modems.
- Telephone Interface, Line cards.
- Data communication equipment.
- Line test equipment

Part Number Code

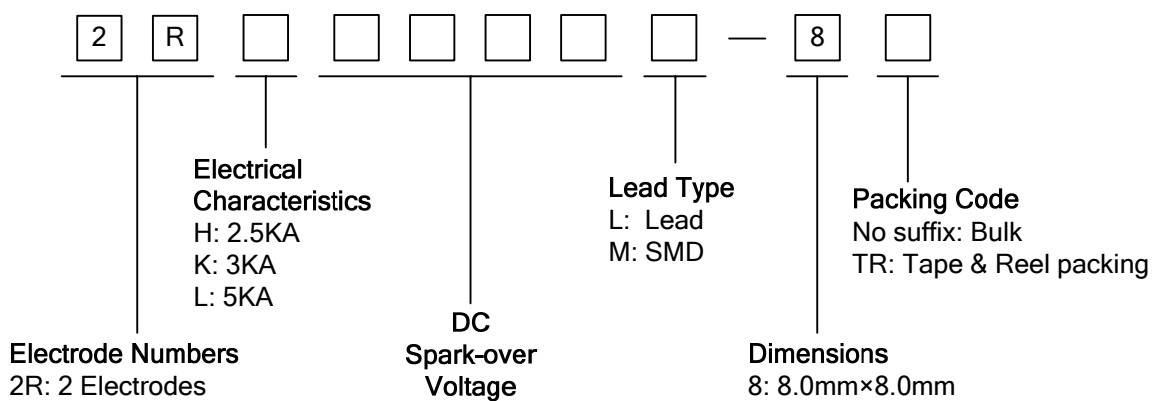

Marking

: BrightKing Logo
 2RL1000-8 : Device Marking Code
 YXXX : Date Code

Dimensions

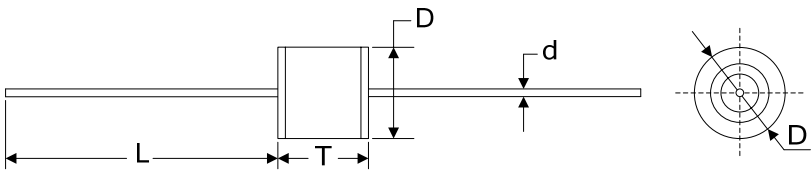
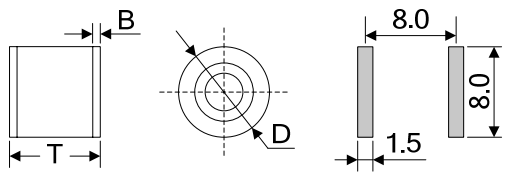
L Type	Symbol	Dimension (mm)		
		Spec.	Tolerance	
	D	8.0	+0.3, -0.5	
	T	8.0	+0.6, -0.1	
	d	0.8	±0.1	
	L	30.0	Max.	
M Type	 Recommended Pad Size	D	8.0	+0.3, -0.5
		T	8.0	+0.6, -0.1
		B	1.1	±0.4

Electrical Characteristics

Part Number ☆	DC Spark-over Voltage	Maximum Impulse Spark-over Voltage	Nominal Impulse Discharge Current	Alternating Discharge Current	Impulse Life	Minimum Insulation Resistance		Maximum Capacitance	AC Withstanding Voltage	Device Marking Code
	100V/s	1000V/μs	8/20μs 10times	50Hz, 1sec	10/1000μs 100A	Test Voltage	(GΩ)	1MHz		
	(V)	(V)	(KA)	(A)	(times)	DC(V)		(pF)		
2RH1400X-8	1400±20%	2200	2.5	2.5	100	500	1.0	1.5	-	2RH1400-8
2RH1600X-8	1600±20%	2400	2.5	2.5	100	500	1.0	1.5	-	2RH1600-8
2RH2000X-8	2000±20%	3000	2.5	2.5	100	500	1.0	1.5	-	2RH2000-8
2RH2500X-8	2500±20%	3600	2.5	2.5	100	500	1.0	1.5	AC1250V,1min	2RH2500-8
2RH2700X-8	2700±20%	4000	2.5	2.5	300*	1000	1.0	1.5	AC1250V,1min	2RH2700-8
2RH3000X-8	3000±20%	4200	2.5	2.5	100	1000	1.0	1.5	AC1500V,1min	2RH3000-8
2RH3500X-8	3500±20%	5000	2.5	2.5	100	1000	1.0	1.5	AC1800V,1min	2RH3500-8
2RK2700X-8	2700±20%	4000	3.0	3.0	300*	1000	1.0	1.5	AC1250V,1min	2RK2700-8
2RK3000X-8	3000±20%	4200	3.0	3.0	300*	1000	1.0	1.5	AC1500V,1min	2RK3000-8
2RK3500X-8	3500±20%	5000	3.0	3.0	100	1000	1.0	1.5	AC1800V,1min	2RK3500-8
2RK4000X-8	4000±20%	5500	3.0	3.0	100	1000	1.0	1.5	AC2000V,1min	2RK4000-8
2RK5000X-8	5000±20%	6400	3.0	3.0	100	1000	1.0	1.5	AC2500V,1min	2RK5000-8
2RK6000X-8	6000±20%	7800	3.0	3.0	100	1000	1.0	1.5	AC3000V,1min	2RK6000-8

* Measured with an 8/20μs waveform, 100A

☆X may be L or M.

Electrical Characteristics

Part Number ☆	DC Spark-over Voltage	Maximum Impulse Spark-over Voltage	Nominal Impulse Discharge Current	Alternating Discharge Current	Impulse Life	Minimum Insulation Resistance		Maximum Capacitance	AC Withstanding Voltage	Device Marking Code
	100V/s	1000V/μs	8/20μs 10times	50Hz, 1sec	10/1000μs 100A	Test Voltage	(GΩ)	1MHz		
	(V)	(V)	(KA)	(A)	(times)	DC(V)		(pF)		
2RL1000X-8	1000±20%	1400	5.0	5.0	100	500	1.0	1.5	-	2RL1000-8
2RL1400X-8	1400±20%	2200	5.0	5.0	100	500	1.0	1.5	-	2RL1400-8
2RL1600X-8	1600±20%	2400	5.0	5.0	100	500	1.0	1.5	-	2RL1600-8
2RL2000X-8	2000±20%	3000	5.0	5.0	100	500	1.0	1.5	-	2RL2000-8
2RL2500X-8	2500±20%	3600	5.0	5.0	100	1000	1.0	1.5	AC1250V,1min	2RL2500-8

Notes: The surface for 2RXXXXXM-8 series products is default for nickel plating, please change to use tin plating if used on PCB boards while soldering, and adding the code "Sn" as suffix of the part number to distinguish. Such as "2RK3000M-8 Sn".

☆X may be L or M.

Electrical Ratings

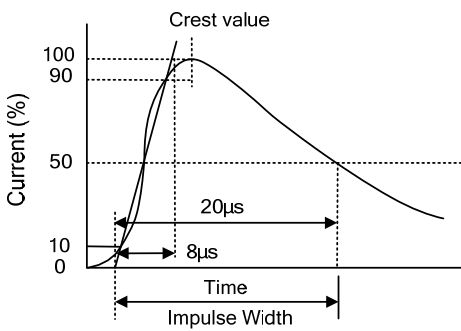
Items	Test Condition/Description	Requirement
DC Spark-over Voltage	The voltage is measured with voltage ramp $dv/dt=100V/s$.	To meet the specified value
Maximum Impulse Spark-over Voltage	The maximum impulse spark-over voltage is measured with voltage ramp $dv/dt=1000V/\mu s$.	
Impulse Discharge Current	Maximum 8/20μs surge current that can be applied between two electrodes, 5 positive and 5 negative surges, with 3 minutes interval time, without causing the DC spark-over voltage to change more than 25% from its initial value. 	
Alternating Discharge Current	Rated RMS value of AC current at 50Hz, 1 sec. for 10 times with interval time 3 min. DC spark-over voltage shall not change more than ±25% from its initial value. $IR > 10^8$ ohms (-20%, +30% for 70~90V).	
Insulation Resistance	The resistance of gas tube shall be measured between two electrodes.	
Capacitance	The capacitance of gas tube shall be measured between two electrodes. Test frequency: 1MHz	

Recommended Soldering Conditions

Wave Soldering

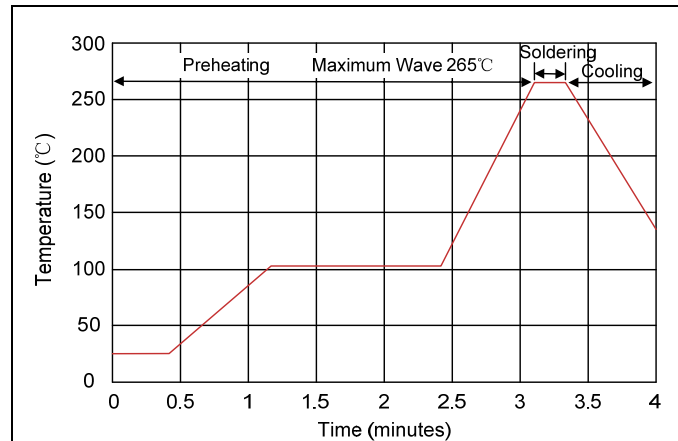

Item	Conditions
Peak Temperature	265°C
Dipping Time	10 seconds
Soldering	1 time

Reflow Soldering

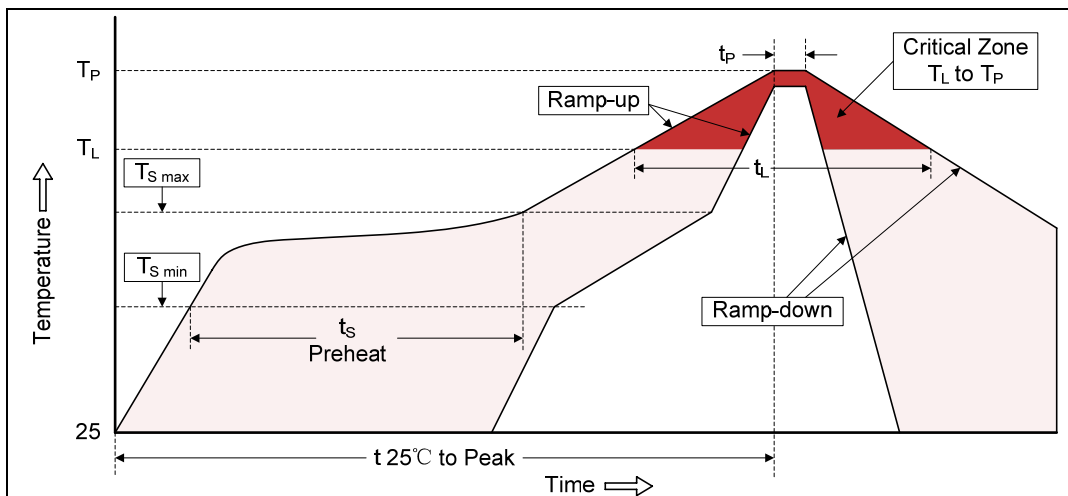

Profile Feature	Pb-Free Assembly
Average ramp-up rate (T_L to T_P)	3°C/second max.
Preheat	
-Temperature Min ($T_{S\ min}$)	150°C
-Temperature Max ($T_{S\ max}$)	200°C
-Time (min to max) (t_s)	60-180 seconds
$T_{S\ max}$ to T_L	
-Ramp-up Rate	3°C/second max.
Time maintained above:	
-Temperature (T_L)	217°C
-Time (t_L)	60-150 seconds
Peak Temperature (T_P)	260°C
Time within 5°C of actual Peak Temperature (t_p)	20-40 seconds
Ramp-down Rate	6°C/second max.
Time 25°C to Peak Temperature	8 minutes max.

Packaging

Axial Packing (Bulk)

Skin packing

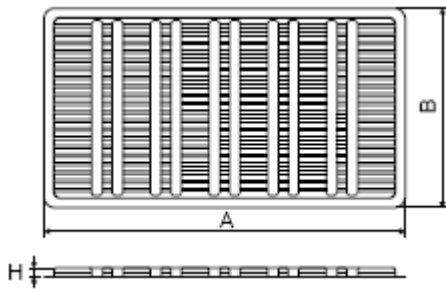

Symbol	Dimension (mm)	
	Spec.	Tolerance
A	264.0	±1.0
B	145.0	±1.0
H	6.5	±0.5
Quantity: 100pcs		

Inner box

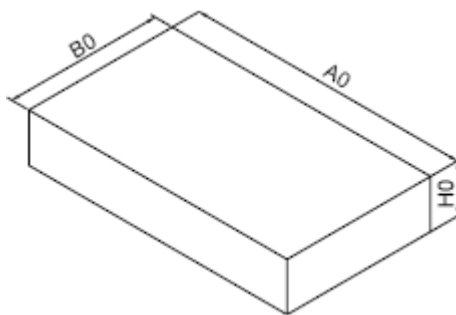

A0	270.0	±2.0
B0	150.0	±1.0
H0	50.0	±1.0
Quantity: 500pcs		

Axial Packing (Tape & Reel)

Tape

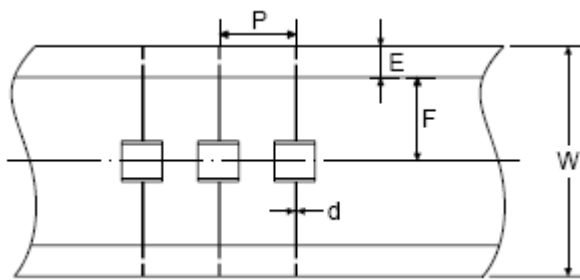

Symbol	Dimension (mm)	
	Spec.	Tolerance
P	10.0	±0.1
W	65.0	±0.1
E	6.0	±0.1
F	26.5	±0.1
d	0.8/1.0	±0.05

Reel

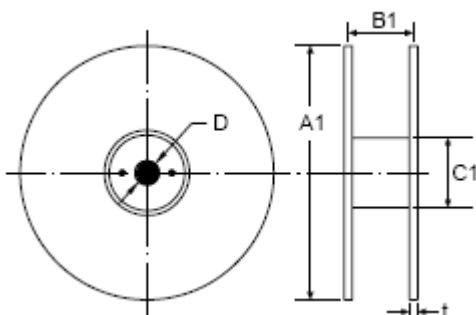

A1	330.0	±1.0
B1	70.0	±1.0
C1	82.0	±1.0
D	25.0	±0.2
t	2.0	±0.2
Quantity: 500pcs		

Packaging

SMD Packing (Tape & Reel)

Tape

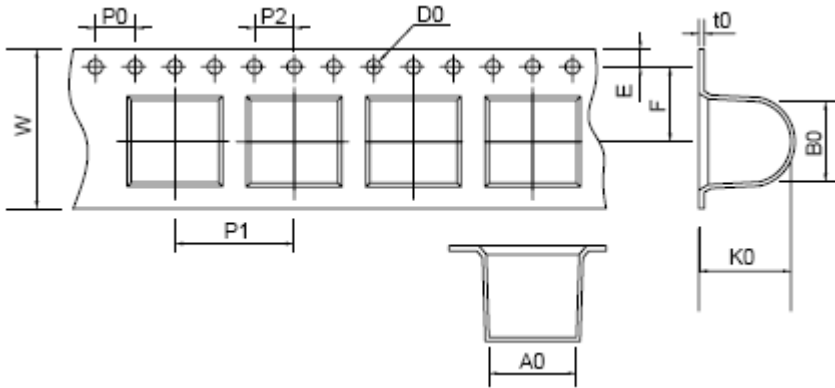

Reel

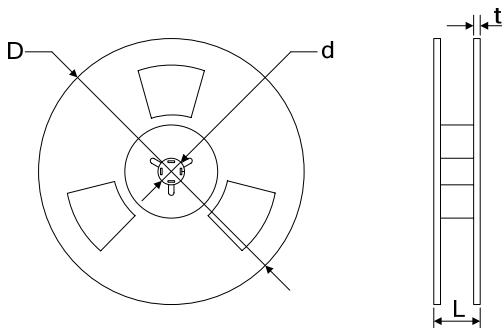

Symbol	Dimension (mm)	
	Spec.	Tolerance
W	16.00	±0.20
P0	4.00	±0.10
P1	12.00	±0.20
P2	4.00	±0.10
D0	1.45	±0.1
E	1.75	±0.10
F	7.50	±0.10
A0	8.80	±0.10
K0	8.30	±0.10
B0	8.30	±0.10
t0	0.50	±0.10
D	330.00	±1.00
d	13.00	±0.50
L	20.00	±0.50
t	2.00	±0.20
Quantity: 500pcs		