

TO Messrs. ALMAR ENTERPRISES CO., LTD.

# ALUMINUM ELECTROLYTIC CAPACITORS SPECIFICATION SHEET

---

|                   |                             |                |
|-------------------|-----------------------------|----------------|
| CUSTOMER PART No. |                             |                |
| Rubycon PART No.  | ML SERIES (PET sleeve type) |                |
| DRAWING No.       | REE - 037661                | ISSUE No.<br>1 |
| ISSUE DATE        | 15 MARCH 2010               |                |



RUBYCON CORPORATION  
ENGINEERING DIVISION

1938-1, NISHIMINOWA, INA-SHI, NAGANO-KEN, JAPAN

TEL No. 0265-72-7116

FAX No. 0265-73-3380

|          |                  |
|----------|------------------|
| DESIGN   | SEIJI IWAI       |
|          |                  |
| CHECK    | TETSUYA MIZU     |
|          |                  |
| APPROVAL | YOSHINORI SASAKI |
|          |                  |

## 1. Scope.

This specification covers polarized aluminum electrolytic capacitors with non-solid electrolyte for use in electronic equipments .

## 2. Reference Standard

JIS C 5141 (1991) and JIS C 5102 (1994) methods for testing.

## 3. Operating Temperature Range

-40°C to +105°C

## 4. Performance Refer to Table-1

## 5. Style and Numbering System

(1) Style CE 04 (Radial Leaded)



| (2) Numbering System | Rated Voltage | Series    | Nominal Capacitance | Tolerance | Option code | Lead Forming | Case size |
|----------------------|---------------|-----------|---------------------|-----------|-------------|--------------|-----------|
|                      | □□□           | <u>ML</u> | □□□                 | <u>M</u>  | <u>EFC</u>  | □□           | □□□ X □□□ |

## 6. Marking

Unless otherwise specified, capacitor shall be clearly marked the following items on its body.

Sleeve color: Black

Lettering color: White

|                                   |   |
|-----------------------------------|---|
| (1) Trade mark                    | <b>Rubycon</b> or    |
| (2) Rated Voltage                 | V   |
| (3) Nominal Capacitance           | μF  |
| (4) Polarity                      |  (Negative Polarity) |
| (5) Series                        | ML  |
| (6) Lot. Number                   |   |
| (7) Maximum Operating Temperature | 105°C   |
| (8) PET sleeve mark               | PET or PE   |

## 7. Vent

On capacitors whose diameter is 6.3mm and greater (except 5mm to 8mm Height), a safety vent shall be provided.

## 8. Notes on use of aluminum electrolytic capacitors

## (1) Charge and discharge

Do not use for the circuit that repeats quick charge or discharge.

## (2) External stress

Do not apply excessive force of pushing, pulling bending, and/or twisting to the main body, lead wire and terminals.

## (3) Heat resistance at soldering process

In the soldering process of PC board with Capacitors mounted, secondary shrinkage or crack of sleeve may be observed when soldering temperature is too high and /or soldering time is too long.

If lead wire of other components or pattern of double sided PC board touches the capacitor, the similar failure may be also originated at pre-heating, heating at hardening process of adhesive and soldering process.

## (4) Insulation and PC board mounting

Sleeve is for marking purpose only.

It is not recognized as insulation materials.

When double sided PC board is employed, note that it could cause a short circuit if lead wire of other components or pattern of double sided PC board touches capacitor. Please avoid circuit pattern runs underneath capacitor.

In addition, case and cathode terminal are not insulated.

## (5) Adhesives and coating materials

Do not use the adhesives and coating materials that contain halogenated organic solvents or chloroprene as polymer.

## (6) Storage

Keep at a normal temperature and humidity. During a long storage time, leakage current will be increased. To prevent heat rise or any trouble that high leakage current possibly causes, voltage treatment is recommended for the capacitors that have been stored for a long time.

ML SERIES

**Rubycon**  
RUBYCON CORPORATION

## &lt;Storage Condition&gt;

\*Aluminum electrolytic capacitors should not be stored in high temperatures or where there is a high level of humidity. The suitable storage condition is 5°C-35°C and less than 75% in relative humidity.

\*Aluminum electrolytic capacitors should not be stored in damp conditions such as water, saltwater spray or oil spray.

\*Do not store aluminum electrolytic capacitors in an environment full of hazardous gas (hydrogen sulfide, sulfurous acid gas, nitrous acid, chlorine gas, ammonia or bromine gas).

\*Aluminum electrolytic capacitors should not be stored under exposure to ozone, ultraviolet rays or radiation.

## (7) Fumigation and halogenated flame retardant

It may cause corrosion of internal electrodes, aluminum cases and terminal surface when the following conditions exist.

\*Fumigation of wooden pallets before shipment to disinfect vermin.

\*Existence of components or parts that contain halogenated flame retardant agent (bromine etc.) together with capacitors.

\*When halogenated detergents of antiseptics for preventing infection of epidemic diseases contact directly to capacitors.

## (8) PC board cleaning after soldering

Please consult us when cleaning is subjected.

◆ Guide to application except the above are described in our catalog and EIAJ RCR-2367C.

EIAJ RCR-2367C: "Safety Application Guide for fixed aluminum electrolytic capacitors for use in electronic equipment."

Published by Japan Electronics and Information Technology Industries Association.

◆Table-1 PERFORMANCE

| ITEMS |  | PERFORMANCE  |      |      |      |      |      |      |
|-------|--|--|------|------|------|------|------|------|
| 1     | Rated Voltage(WV)<br>Surge Voltage (SV)                        | WV(V.DC)   | 6.3  | 10   | 16   | 25   | 35   | 50   |
|       |  | SV(V.DC)   | 8    | 13   | 20   | 32   | 44   | 63   |
| 2     | Nominal Capacitance<br>(Tolerance)                             | <Criteria><br>1 to 1000 $\mu$ F( $\pm$ 20%)<br><br><Condition><br>{ Measuring Frequency : 120Hz $\pm$ 20%<br>Measuring Voltage : Not more than 0.5Vrms + 1.5 to 2.0V.DC<br>Measuring Temperature : 20 $\pm$ 2 °C }   |      |      |      |      |      |      |
| 3     | Leakage Current  | <Condition><br>The rated voltage shall be applied between terminals of capacitor such that the terminal voltage will reach the rated voltage within one minute and the leakage current shall be measured at 2 minutes after the voltage has reached the rated voltage across a 1000 $\pm$ 10 $\Omega$ series protection resistor. Then the current value shall not exceed value calculated from following formula.<br><br><Criteria><br>$I=0.01CV$ or 3 $\mu$ A whichever is greater<br><br>where I : Leakage current in $\mu$ A.<br>C : Nominal capacitance in $\mu$ F.<br>V : Rated voltage in V.DC. |      |      |      |      |      |      |
| 4     | Dissipation Factor<br>(tan $\delta$ :Tangent of<br>loss angle) | WV(V.DC)   | 6.3  | 10   | 16   | 25   | 35   | 50   |
|       |  | tan $\delta$   | 0.40 | 0.35 | 0.30 | 0.25 | 0.20 | 0.20 |
|       |  | <Condition><br>See ITEM 2, Nominal Capacitance, for measuring frequency, voltage and temperature.  |      |      |      |      |      |      |

| 5                        | Terminal Strength                 | <p>&lt;Condition&gt;<br/> <b>Tensile Strength of Terminals</b><br/> The body of capacitor shall be fixed and the tensile force of following table shall be applied to the terminal in lead out direction of the terminal for 10±1 seconds.</p> <p><b>Bending Strength of Terminals</b><br/> The body of capacitor shall be held in such a way that the regular lead-out axis of lead wire terminal becomes vertical. The weight of following table shall be suspended from the end of terminal. In this condition, after the body of sample is bent through 90 degrees, it shall be returned to the original position. Next the body shall be reversibly bent through 90 degrees and again returned to the original position.</p> <table border="1" data-bbox="544 595 1337 719"> <thead> <tr> <th>Diameter of lead wire</th> <th>Tensile force<br/>N{kgf}</th> <th>Bending force<br/>N{kgf}</th> </tr> </thead> <tbody> <tr> <td>0.5mm and less</td> <td>5{0.51}</td> <td>2.5{0.25}</td> </tr> <tr> <td>Over 0.5mm to 0.8mm incl</td> <td>10{1.0}</td> <td>5 {0.51}</td> </tr> </tbody> </table> <p>&lt;Criteria&gt;<br/> Notable changes shall not be found, as breakage or looseness in the terminal.</p>   | Diameter of lead wire | Tensile force<br>N{kgf}  | Bending force<br>N{kgf} | 0.5mm and less | 5{0.51} | 2.5{0.25}                         | Over 0.5mm to 0.8mm incl | 10{1.0} | 5 {0.51} |   |       |    |   |      |    |   |       |        |   |      |                                   |          |                 |   |        |                    |                                    |                    |                                   |                 |   |        |                    |                                    |                    |                                   |                 |                                   |          |     |    |    |    |    |    |                   |   |   |   |   |   |   |                   |    |    |   |   |   |   |
|--------------------------|-----------------------------------|--|-----------------------|--------------------------|-------------------------|----------------|---------|-----------------------------------|--------------------------|---------|----------|---|-------|----|---|------|----|---|-------|--------|---|------|-----------------------------------|----------|-----------------|---|--------|--------------------|------------------------------------|--------------------|-----------------------------------|-----------------|---|--------|--------------------|------------------------------------|--------------------|-----------------------------------|-----------------|-----------------------------------|----------|-----|----|----|----|----|----|-------------------|---|---|---|---|---|---|-------------------|----|----|---|---|---|---|
| Diameter of lead wire    | Tensile force<br>N{kgf}           | Bending force<br>N{kgf}  |                       |                          |                         |                |         |                                   |                          |         |          |   |       |    |   |      |    |   |       |        |   |      |                                   |          |                 |   |        |                    |                                    |                    |                                   |                 |   |        |                    |                                    |                    |                                   |                 |                                   |          |     |    |    |    |    |    |                   |   |   |   |   |   |   |                   |    |    |   |   |   |   |
| 0.5mm and less           | 5{0.51}                           | 2.5{0.25}  |                       |                          |                         |                |         |                                   |                          |         |          |   |       |    |   |      |    |   |       |        |   |      |                                   |          |                 |   |        |                    |                                    |                    |                                   |                 |   |        |                    |                                    |                    |                                   |                 |                                   |          |     |    |    |    |    |    |                   |   |   |   |   |   |   |                   |    |    |   |   |   |   |
| Over 0.5mm to 0.8mm incl | 10{1.0}                           | 5 {0.51}   |                       |                          |                         |                |         |                                   |                          |         |          |   |       |    |   |      |    |   |       |        |   |      |                                   |          |                 |   |        |                    |                                    |                    |                                   |                 |   |        |                    |                                    |                    |                                   |                 |                                   |          |     |    |    |    |    |    |                   |   |   |   |   |   |   |                   |    |    |   |   |   |   |
| 6                        | Temperature Coefficient and Drift | <p>&lt;Condition&gt;</p> <table border="1" data-bbox="544 875 1356 1200"> <thead> <tr> <th>STEP</th> <th>Testing Temperature (°C)</th> <th>Time</th> </tr> </thead> <tbody> <tr> <td>1</td> <td>20±2</td> <td>Time to reach thermal equilibrium</td> </tr> <tr> <td>2</td> <td>-40±3</td> <td>//</td> </tr> <tr> <td>3</td> <td>-25±3</td> <td>//</td> </tr> <tr> <td>4</td> <td>20±2</td> <td>//</td> </tr> <tr> <td>5</td> <td>105±2</td> <td>2 hrs.</td> </tr> <tr> <td>6</td> <td>20±2</td> <td>Time to reach thermal equilibrium</td> </tr> </tbody> </table> <p>Capacitance, D.F. and Impedance shall be measured at 120Hz.</p> <p>&lt;Criteria&gt;</p> <table border="1" data-bbox="544 1283 1490 1547"> <tbody> <tr> <td>STEP 2,3</td> <td>Impedance Ratio</td> <td>The value of ratio to STEP 1 not more than value of following table</td> </tr> <tr> <td rowspan="3">STEP 5</td> <td>Capacitance Change</td> <td>Within ±25% of the value of STEP 1</td> </tr> <tr> <td>Dissipation Factor</td> <td>Not more than the specified value</td> </tr> <tr> <td>Leakage Current</td> <td>Not more than 8 times the specified value</td> </tr> <tr> <td rowspan="3">STEP 6</td> <td>Capacitance Change</td> <td>Within ±10% of the value of STEP 1</td> </tr> <tr> <td>Dissipation Factor</td> <td>Not more than the specified value</td> </tr> <tr> <td>Leakage Current</td> <td>Not more than the specified value</td> </tr> </tbody> </table> <table border="1" data-bbox="544 1574 1184 1709"> <tbody> <tr> <td>WV(V.DC)</td> <td>6.3</td> <td>10</td> <td>16</td> <td>25</td> <td>35</td> <td>50</td> </tr> <tr> <td>Z(-25°C)/Z(+20°C)</td> <td>6</td> <td>4</td> <td>4</td> <td>3</td> <td>2</td> <td>2</td> </tr> <tr> <td>Z(-40°C)/Z(+20°C)</td> <td>12</td> <td>10</td> <td>8</td> <td>6</td> <td>4</td> <td>4</td> </tr> </tbody> </table> | STEP                  | Testing Temperature (°C) | Time                    | 1              | 20±2    | Time to reach thermal equilibrium | 2                        | -40±3   | //       | 3 | -25±3 | // | 4 | 20±2 | // | 5 | 105±2 | 2 hrs. | 6 | 20±2 | Time to reach thermal equilibrium | STEP 2,3 | Impedance Ratio | The value of ratio to STEP 1 not more than value of following table | STEP 5 | Capacitance Change | Within ±25% of the value of STEP 1 | Dissipation Factor | Not more than the specified value | Leakage Current | Not more than 8 times the specified value | STEP 6 | Capacitance Change | Within ±10% of the value of STEP 1 | Dissipation Factor | Not more than the specified value | Leakage Current | Not more than the specified value | WV(V.DC) | 6.3 | 10 | 16 | 25 | 35 | 50 | Z(-25°C)/Z(+20°C) | 6 | 4 | 4 | 3 | 2 | 2 | Z(-40°C)/Z(+20°C) | 12 | 10 | 8 | 6 | 4 | 4 |
| STEP                     | Testing Temperature (°C)          | Time   |                       |                          |                         |                |         |                                   |                          |         |          |   |       |    |   |      |    |   |       |        |   |      |                                   |          |                 |   |        |                    |                                    |                    |                                   |                 |   |        |                    |                                    |                    |                                   |                 |                                   |          |     |    |    |    |    |    |                   |   |   |   |   |   |   |                   |    |    |   |   |   |   |
| 1                        | 20±2                              | Time to reach thermal equilibrium  |                       |                          |                         |                |         |                                   |                          |         |          |   |       |    |   |      |    |   |       |        |   |      |                                   |          |                 |   |        |                    |                                    |                    |                                   |                 |   |        |                    |                                    |                    |                                   |                 |                                   |          |     |    |    |    |    |    |                   |   |   |   |   |   |   |                   |    |    |   |   |   |   |
| 2                        | -40±3                             | //   |                       |                          |                         |                |         |                                   |                          |         |          |   |       |    |   |      |    |   |       |        |   |      |                                   |          |                 |   |        |                    |                                    |                    |                                   |                 |   |        |                    |                                    |                    |                                   |                 |                                   |          |     |    |    |    |    |    |                   |   |   |   |   |   |   |                   |    |    |   |   |   |   |
| 3                        | -25±3                             | //   |                       |                          |                         |                |         |                                   |                          |         |          |   |       |    |   |      |    |   |       |        |   |      |                                   |          |                 |   |        |                    |                                    |                    |                                   |                 |   |        |                    |                                    |                    |                                   |                 |                                   |          |     |    |    |    |    |    |                   |   |   |   |   |   |   |                   |    |    |   |   |   |   |
| 4                        | 20±2                              | //   |                       |                          |                         |                |         |                                   |                          |         |          |   |       |    |   |      |    |   |       |        |   |      |                                   |          |                 |   |        |                    |                                    |                    |                                   |                 |   |        |                    |                                    |                    |                                   |                 |                                   |          |     |    |    |    |    |    |                   |   |   |   |   |   |   |                   |    |    |   |   |   |   |
| 5                        | 105±2                             | 2 hrs.   |                       |                          |                         |                |         |                                   |                          |         |          |   |       |    |   |      |    |   |       |        |   |      |                                   |          |                 |   |        |                    |                                    |                    |                                   |                 |   |        |                    |                                    |                    |                                   |                 |                                   |          |     |    |    |    |    |    |                   |   |   |   |   |   |   |                   |    |    |   |   |   |   |
| 6                        | 20±2                              | Time to reach thermal equilibrium  |                       |                          |                         |                |         |                                   |                          |         |          |   |       |    |   |      |    |   |       |        |   |      |                                   |          |                 |   |        |                    |                                    |                    |                                   |                 |   |        |                    |                                    |                    |                                   |                 |                                   |          |     |    |    |    |    |    |                   |   |   |   |   |   |   |                   |    |    |   |   |   |   |
| STEP 2,3                 | Impedance Ratio                   | The value of ratio to STEP 1 not more than value of following table  |                       |                          |                         |                |         |                                   |                          |         |          |   |       |    |   |      |    |   |       |        |   |      |                                   |          |                 |   |        |                    |                                    |                    |                                   |                 |   |        |                    |                                    |                    |                                   |                 |                                   |          |     |    |    |    |    |    |                   |   |   |   |   |   |   |                   |    |    |   |   |   |   |
| STEP 5                   | Capacitance Change                | Within ±25% of the value of STEP 1   |                       |                          |                         |                |         |                                   |                          |         |          |   |       |    |   |      |    |   |       |        |   |      |                                   |          |                 |   |        |                    |                                    |                    |                                   |                 |   |        |                    |                                    |                    |                                   |                 |                                   |          |     |    |    |    |    |    |                   |   |   |   |   |   |   |                   |    |    |   |   |   |   |
|                          | Dissipation Factor                | Not more than the specified value  |                       |                          |                         |                |         |                                   |                          |         |          |   |       |    |   |      |    |   |       |        |   |      |                                   |          |                 |   |        |                    |                                    |                    |                                   |                 |   |        |                    |                                    |                    |                                   |                 |                                   |          |     |    |    |    |    |    |                   |   |   |   |   |   |   |                   |    |    |   |   |   |   |
|                          | Leakage Current                   | Not more than 8 times the specified value  |                       |                          |                         |                |         |                                   |                          |         |          |   |       |    |   |      |    |   |       |        |   |      |                                   |          |                 |   |        |                    |                                    |                    |                                   |                 |   |        |                    |                                    |                    |                                   |                 |                                   |          |     |    |    |    |    |    |                   |   |   |   |   |   |   |                   |    |    |   |   |   |   |
| STEP 6                   | Capacitance Change                | Within ±10% of the value of STEP 1   |                       |                          |                         |                |         |                                   |                          |         |          |   |       |    |   |      |    |   |       |        |   |      |                                   |          |                 |   |        |                    |                                    |                    |                                   |                 |   |        |                    |                                    |                    |                                   |                 |                                   |          |     |    |    |    |    |    |                   |   |   |   |   |   |   |                   |    |    |   |   |   |   |
|                          | Dissipation Factor                | Not more than the specified value  |                       |                          |                         |                |         |                                   |                          |         |          |   |       |    |   |      |    |   |       |        |   |      |                                   |          |                 |   |        |                    |                                    |                    |                                   |                 |   |        |                    |                                    |                    |                                   |                 |                                   |          |     |    |    |    |    |    |                   |   |   |   |   |   |   |                   |    |    |   |   |   |   |
|                          | Leakage Current                   | Not more than the specified value  |                       |                          |                         |                |         |                                   |                          |         |          |   |       |    |   |      |    |   |       |        |   |      |                                   |          |                 |   |        |                    |                                    |                    |                                   |                 |   |        |                    |                                    |                    |                                   |                 |                                   |          |     |    |    |    |    |    |                   |   |   |   |   |   |   |                   |    |    |   |   |   |   |
| WV(V.DC)                 | 6.3                               | 10   | 16                    | 25                       | 35                      | 50             |         |                                   |                          |         |          |   |       |    |   |      |    |   |       |        |   |      |                                   |          |                 |   |        |                    |                                    |                    |                                   |                 |   |        |                    |                                    |                    |                                   |                 |                                   |          |     |    |    |    |    |    |                   |   |   |   |   |   |   |                   |    |    |   |   |   |   |
| Z(-25°C)/Z(+20°C)        | 6                                 | 4  | 4                     | 3                        | 2                       | 2              |         |                                   |                          |         |          |   |       |    |   |      |    |   |       |        |   |      |                                   |          |                 |   |        |                    |                                    |                    |                                   |                 |   |        |                    |                                    |                    |                                   |                 |                                   |          |     |    |    |    |    |    |                   |   |   |   |   |   |   |                   |    |    |   |   |   |   |
| Z(-40°C)/Z(+20°C)        | 12                                | 10   | 8                     | 6                        | 4                       | 4              |         |                                   |                          |         |          |   |       |    |   |      |    |   |       |        |   |      |                                   |          |                 |   |        |                    |                                    |                    |                                   |                 |   |        |                    |                                    |                    |                                   |                 |                                   |          |     |    |    |    |    |    |                   |   |   |   |   |   |   |                   |    |    |   |   |   |   |

| 7                         | Load Life Test   | <p>&lt;Condition&gt;<br/>Capacitors shall be applied the rated voltage continuously through 1000 Ω series protective resistor (with maximum ripple current) at 105±2°C for following test period. After the test and returned in standard condition for 1 to 2 hours, and the capacitor shall meet following requirements.</p> <table border="1" data-bbox="606 425 1069 537"> <thead> <tr> <th>Case Size</th> <th>Life time</th> </tr> </thead> <tbody> <tr> <td>L=5mm</td> <td>3000 <math>\begin{smallmatrix} +72 \\ 0 \end{smallmatrix}</math></td> </tr> <tr> <td>L≥7mm</td> <td>5000 <math>\begin{smallmatrix} +72 \\ 0 \end{smallmatrix}</math></td> </tr> </tbody> </table> <p>&lt;Criteria&gt;</p> <table border="1" data-bbox="534 560 1436 705"> <tbody> <tr> <td>Leakage Current</td> <td>Not more than the specified value</td> </tr> <tr> <td>Capacitance Change</td> <td>Within ±30% of the initial value</td> </tr> <tr> <td>Dissipation Factor</td> <td>Not more than 300% of the specified value</td> </tr> <tr> <td>Appearance</td> <td>Notable changes shall not be found</td> </tr> </tbody> </table> | Case Size                 | Life time                         | L=5mm                  | 3000 $\begin{smallmatrix} +72 \\ 0 \end{smallmatrix}$ | L≥7mm              | 5000 $\begin{smallmatrix} +72 \\ 0 \end{smallmatrix}$ | Leakage Current           | Not more than the specified value  | Capacitance Change | Within ±30% of the initial value | Dissipation Factor | Not more than 300% of the specified value | Appearance | Notable changes shall not be found |
|---------------------------|--|---|---------------------------|-----------------------------------|------------------------|---|--------------------|---|---------------------------|--|--------------------|----------------------------------|--------------------|---|------------|------------------------------------|
| Case Size                 | Life time  |   |                           |                                   |                        |   |                    |   |                           |  |                    |                                  |                    |   |            |                                    |
| L=5mm                     | 3000 $\begin{smallmatrix} +72 \\ 0 \end{smallmatrix}$  |   |                           |                                   |                        |   |                    |   |                           |  |                    |                                  |                    |   |            |                                    |
| L≥7mm                     | 5000 $\begin{smallmatrix} +72 \\ 0 \end{smallmatrix}$  |   |                           |                                   |                        |   |                    |   |                           |  |                    |                                  |                    |   |            |                                    |
| Leakage Current           | Not more than the specified value  |   |                           |                                   |                        |   |                    |   |                           |  |                    |                                  |                    |   |            |                                    |
| Capacitance Change        | Within ±30% of the initial value   |   |                           |                                   |                        |   |                    |   |                           |  |                    |                                  |                    |   |            |                                    |
| Dissipation Factor        | Not more than 300% of the specified value  |   |                           |                                   |                        |   |                    |   |                           |  |                    |                                  |                    |   |            |                                    |
| Appearance                | Notable changes shall not be found   |   |                           |                                   |                        |   |                    |   |                           |  |                    |                                  |                    |   |            |                                    |
| 8                         | Shelf Life Test  | <p>&lt;Condition&gt;<br/>Capacitors shall be stored at 105±2°C with no voltage applied for 1000 <math>\begin{smallmatrix} +48 \\ 0 \end{smallmatrix}</math> hours. After the test and returned in standard condition for 1 to 2 hours and the capacitor shall meet following requirements. (If any doubt arises on the judgment, the capacitors shall be subjected to voltage treatment specified in JIS C 5141,5.2.)</p> <p>&lt;Criteria&gt;</p> <table border="1" data-bbox="534 929 1444 1075"> <tbody> <tr> <td>Leakage Current</td> <td>Not more than the specified value</td> </tr> <tr> <td>Capacitance Change</td> <td>Within ±25% of the initial value</td> </tr> <tr> <td>Dissipation Factor</td> <td>Not more than 200% of the specified value</td> </tr> <tr> <td>Appearance</td> <td>Notable changes shall not be found</td> </tr> </tbody> </table>   | Leakage Current           | Not more than the specified value | Capacitance Change     | Within ±25% of the initial value                      | Dissipation Factor | Not more than 200% of the specified value             | Appearance                | Notable changes shall not be found   |                    |                                  |                    |   |            |                                    |
| Leakage Current           | Not more than the specified value  |   |                           |                                   |                        |   |                    |   |                           |  |                    |                                  |                    |   |            |                                    |
| Capacitance Change        | Within ±25% of the initial value   |   |                           |                                   |                        |   |                    |   |                           |  |                    |                                  |                    |   |            |                                    |
| Dissipation Factor        | Not more than 200% of the specified value  |   |                           |                                   |                        |   |                    |   |                           |  |                    |                                  |                    |   |            |                                    |
| Appearance                | Notable changes shall not be found   |   |                           |                                   |                        |   |                    |   |                           |  |                    |                                  |                    |   |            |                                    |
| 9                         | Surge Voltage  | <p>&lt;Condition&gt;<br/>Capacitors shall be applied the surge voltage through a (100±50)/C<sub>R</sub> [kΩ] resistor in series for 30±5 seconds in every 6±0.5 minutes at 15 to 35°C. Procedure shall be repeated 1000 times. Then the capacitors shall be left under normal humidity for 1 to 2 hours before measurement.<br/>[C<sub>R</sub> : Nominal Capacitance (μF)]</p> <p>&lt;Criteria&gt;</p> <table border="1" data-bbox="534 1310 1444 1456"> <tbody> <tr> <td>Leakage Current</td> <td>Not more than the specified value</td> </tr> <tr> <td>Capacitance Change</td> <td>Within ±15% of the initial value</td> </tr> <tr> <td>Dissipation Factor</td> <td>Not more than the specified value</td> </tr> <tr> <td>Appearance</td> <td>Notable changes shall not be found</td> </tr> </tbody> </table> <p>◇This test simulates overvoltage at abnormal situations, and not be hypothesizing that overvoltage is always applied.</p>  | Leakage Current           | Not more than the specified value | Capacitance Change     | Within ±15% of the initial value                      | Dissipation Factor | Not more than the specified value                     | Appearance                | Notable changes shall not be found   |                    |                                  |                    |   |            |                                    |
| Leakage Current           | Not more than the specified value  |   |                           |                                   |                        |   |                    |   |                           |  |                    |                                  |                    |   |            |                                    |
| Capacitance Change        | Within ±15% of the initial value   |   |                           |                                   |                        |   |                    |   |                           |  |                    |                                  |                    |   |            |                                    |
| Dissipation Factor        | Not more than the specified value  |   |                           |                                   |                        |   |                    |   |                           |  |                    |                                  |                    |   |            |                                    |
| Appearance                | Notable changes shall not be found   |   |                           |                                   |                        |   |                    |   |                           |  |                    |                                  |                    |   |            |                                    |
| 10                        | Vibration Test   | <p>&lt;Condition&gt;<br/>Testing shall be done out in 3 AXIS for 2 hours each (total 6 hours) as below.<br/>Fix lead wire at a point not more than 4mm from the body.</p> <table border="1" data-bbox="526 1668 1133 1758"> <tbody> <tr> <td>Vibration frequency range</td> <td>: 10 to 55Hz</td> </tr> <tr> <td>Peak to peak amplitude</td> <td>: 1.5mm</td> </tr> <tr> <td>Sweep rate</td> <td>: 10 to 55 to 10Hz, In about 1min.</td> </tr> </tbody> </table> <p>&lt;Criteria&gt;</p> <table border="1" data-bbox="534 1803 1268 1982"> <tbody> <tr> <td>Capacitance (During test)</td> <td>Measured value shall be stable.<br/>(The time from one end to the other of the vibration frequency within last 30 minutes at last direction.)</td> </tr> <tr> <td>Capacitance Change</td> <td>Within ±5% of the initial value</td> </tr> <tr> <td>Appearance</td> <td>Notable changes shall not be found</td> </tr> </tbody> </table>  | Vibration frequency range | : 10 to 55Hz                      | Peak to peak amplitude | : 1.5mm   | Sweep rate         | : 10 to 55 to 10Hz, In about 1min.                    | Capacitance (During test) | Measured value shall be stable.<br>(The time from one end to the other of the vibration frequency within last 30 minutes at last direction.) | Capacitance Change | Within ±5% of the initial value  | Appearance         | Notable changes shall not be found        |            |                                    |
| Vibration frequency range | : 10 to 55Hz   |   |                           |                                   |                        |   |                    |   |                           |  |                    |                                  |                    |   |            |                                    |
| Peak to peak amplitude    | : 1.5mm  |   |                           |                                   |                        |   |                    |   |                           |  |                    |                                  |                    |   |            |                                    |
| Sweep rate                | : 10 to 55 to 10Hz, In about 1min.   |   |                           |                                   |                        |   |                    |   |                           |  |                    |                                  |                    |   |            |                                    |
| Capacitance (During test) | Measured value shall be stable.<br>(The time from one end to the other of the vibration frequency within last 30 minutes at last direction.) |   |                           |                                   |                        |   |                    |   |                           |  |                    |                                  |                    |   |            |                                    |
| Capacitance Change        | Within ±5% of the initial value  |   |                           |                                   |                        |   |                    |   |                           |  |                    |                                  |                    |   |            |                                    |
| Appearance                | Notable changes shall not be found   |   |                           |                                   |                        |   |                    |   |                           |  |                    |                                  |                    |   |            |                                    |

| 11                      | Solderability                          | <p>&lt;Condition&gt;<br/>Terminals of the capacitor shall be immersed in flux (ethanol solution of the rosin, 25 wt% rosin) for 5 to 10 seconds and shall be immersed in the solder bath (235±5°C) and held for 2±0.5 seconds, and pulled out at the same speed.</p> <p>&lt;Criteria&gt;<br/>At least 3/4 of circumferential surface of dipped portion of the terminal shall be covered with new solder.</p>  |                 |                                   |                    |                                  |                    |                                   |                 |                                    |  |  |  |  |   |      |      |      |      |      |            |      |      |      |      |      |          |      |      |      |      |      |             |      |      |      |      |      |                         |     |    |     |             |     |     |     |
|-------------------------|--|---|-----------------|-----------------------------------|--------------------|----------------------------------|--------------------|-----------------------------------|-----------------|------------------------------------|--|--|--|--|---|------|------|------|------|------|------------|------|------|------|------|------|----------|------|------|------|------|------|-------------|------|------|------|------|------|-------------------------|-----|----|-----|-------------|-----|-----|-----|
| 12                      | Resistance to Solder Heat              | <p>&lt;Condition&gt;<br/>Terminals of the capacitor shall be immersed into solder bath at 260±5°C for 10±1 seconds up to 1.5 to 2.0mm from the body of capacitor.<br/>Then the capacitors shall be left under the normal temperature and normal humidity for 1 to 2 hours before measurement.</p> <p>&lt;Criteria&gt;</p> <table border="1" data-bbox="533 721 1445 869"> <tr> <td>Leakage Current</td> <td>Not more than the specified value</td> </tr> <tr> <td>Capacitance Change</td> <td>Within ±10% of the initial value</td> </tr> <tr> <td>Dissipation Factor</td> <td>Not more than the specified value</td> </tr> <tr> <td>Appearance</td> <td>Notable changes shall not be found</td> </tr> </table>   | Leakage Current | Not more than the specified value | Capacitance Change | Within ±10% of the initial value | Dissipation Factor | Not more than the specified value | Appearance      | Notable changes shall not be found |  |  |  |  |   |      |      |      |      |      |            |      |      |      |      |      |          |      |      |      |      |      |             |      |      |      |      |      |                         |     |    |     |             |     |     |     |
| Leakage Current         | Not more than the specified value      |   |                 |                                   |                    |                                  |                    |                                   |                 |                                    |  |  |  |  |   |      |      |      |      |      |            |      |      |      |      |      |          |      |      |      |      |      |             |      |      |      |      |      |                         |     |    |     |             |     |     |     |
| Capacitance Change      | Within ±10% of the initial value       |   |                 |                                   |                    |                                  |                    |                                   |                 |                                    |  |  |  |  |   |      |      |      |      |      |            |      |      |      |      |      |          |      |      |      |      |      |             |      |      |      |      |      |                         |     |    |     |             |     |     |     |
| Dissipation Factor      | Not more than the specified value      |   |                 |                                   |                    |                                  |                    |                                   |                 |                                    |  |  |  |  |   |      |      |      |      |      |            |      |      |      |      |      |          |      |      |      |      |      |             |      |      |      |      |      |                         |     |    |     |             |     |     |     |
| Appearance              | Notable changes shall not be found     |   |                 |                                   |                    |                                  |                    |                                   |                 |                                    |  |  |  |  |   |      |      |      |      |      |            |      |      |      |      |      |          |      |      |      |      |      |             |      |      |      |      |      |                         |     |    |     |             |     |     |     |
| 13                      | Resistance to Damp Heat (Steady State) | <p>&lt;Condition&gt;<br/>Capacitors shall be stored in the ambient of 40±2°C and relative humidity 90 to 95% for 240±8 hours. Then the capacitors shall be left under the normal temperature and normal humidity for 1 to 2 hours before measurement.</p> <p>&lt;Criteria&gt;</p> <table border="1" data-bbox="533 1070 1445 1218"> <tr> <td>Leakage Current</td> <td>Not more than the specified value</td> </tr> <tr> <td>Capacitance Change</td> <td>Within ±15% of the initial value</td> </tr> <tr> <td>Dissipation Factor</td> <td>Not more than the specified value</td> </tr> <tr> <td>Appearance</td> <td>Notable changes shall not be found</td> </tr> </table>   | Leakage Current | Not more than the specified value | Capacitance Change | Within ±15% of the initial value | Dissipation Factor | Not more than the specified value | Appearance      | Notable changes shall not be found |  |  |  |  |   |      |      |      |      |      |            |      |      |      |      |      |          |      |      |      |      |      |             |      |      |      |      |      |                         |     |    |     |             |     |     |     |
| Leakage Current         | Not more than the specified value      |   |                 |                                   |                    |                                  |                    |                                   |                 |                                    |  |  |  |  |   |      |      |      |      |      |            |      |      |      |      |      |          |      |      |      |      |      |             |      |      |      |      |      |                         |     |    |     |             |     |     |     |
| Capacitance Change      | Within ±15% of the initial value       |   |                 |                                   |                    |                                  |                    |                                   |                 |                                    |  |  |  |  |   |      |      |      |      |      |            |      |      |      |      |      |          |      |      |      |      |      |             |      |      |      |      |      |                         |     |    |     |             |     |     |     |
| Dissipation Factor      | Not more than the specified value      |   |                 |                                   |                    |                                  |                    |                                   |                 |                                    |  |  |  |  |   |      |      |      |      |      |            |      |      |      |      |      |          |      |      |      |      |      |             |      |      |      |      |      |                         |     |    |     |             |     |     |     |
| Appearance              | Notable changes shall not be found     |   |                 |                                   |                    |                                  |                    |                                   |                 |                                    |  |  |  |  |   |      |      |      |      |      |            |      |      |      |      |      |          |      |      |      |      |      |             |      |      |      |      |      |                         |     |    |     |             |     |     |     |
| 14                      | Maximum Permissible Ripple Current     | <p>(1)The maximum permissible ripple current is the maximum A.C. current at 120Hz and can be applied at maximum operating temperature.<br/>(2)The combined value of D.C. voltage and the peak A.C. voltage shall not exceed the rated voltage and shall not be reverse voltage.</p> <p>&lt;Frequency Coefficient&gt;</p> <table border="1" data-bbox="533 1415 1422 1675"> <thead> <tr> <th>Frequency(Hz)</th> <th>60(50)</th> <th>120</th> <th>500</th> <th>1k</th> <th>10k≤</th> </tr> </thead> <tbody> <tr> <td>Capacitance(μF)</td> <td></td> <td></td> <td></td> <td></td> <td></td> </tr> <tr> <td>1</td> <td>0.50</td> <td>1.00</td> <td>1.20</td> <td>1.30</td> <td>1.50</td> </tr> <tr> <td>2.2 to 6.8</td> <td>0.65</td> <td>1.00</td> <td>1.20</td> <td>1.30</td> <td>1.50</td> </tr> <tr> <td>10 to 82</td> <td>0.80</td> <td>1.00</td> <td>1.20</td> <td>1.30</td> <td>1.50</td> </tr> <tr> <td>100 to 1000</td> <td>0.80</td> <td>1.00</td> <td>1.10</td> <td>1.15</td> <td>1.20</td> </tr> </tbody> </table> <p>&lt; Temperature Coefficient &gt;</p> <table border="1" data-bbox="533 1729 1150 1809"> <tr> <td>Ambient Temperature(°C)</td> <td>105</td> <td>85</td> <td>65≥</td> </tr> <tr> <td>Coefficient</td> <td>1.0</td> <td>1.7</td> <td>2.1</td> </tr> </table> <p>◇Temperature coefficient shows a limit of ripple current exceeding the rated ripple current that can be passed through a capacitor at each temperature when the life expectancy of a capacitor becomes to be nearly equal with the lifetime at the rated maximum operating temperature.</p> | Frequency(Hz)   | 60(50)                            | 120                | 500                              | 1k                 | 10k≤                              | Capacitance(μF) |                                    |  |  |  |  | 1 | 0.50 | 1.00 | 1.20 | 1.30 | 1.50 | 2.2 to 6.8 | 0.65 | 1.00 | 1.20 | 1.30 | 1.50 | 10 to 82 | 0.80 | 1.00 | 1.20 | 1.30 | 1.50 | 100 to 1000 | 0.80 | 1.00 | 1.10 | 1.15 | 1.20 | Ambient Temperature(°C) | 105 | 85 | 65≥ | Coefficient | 1.0 | 1.7 | 2.1 |
| Frequency(Hz)           | 60(50)                                 | 120   | 500             | 1k                                | 10k≤               |                                  |                    |                                   |                 |                                    |  |  |  |  |   |      |      |      |      |      |            |      |      |      |      |      |          |      |      |      |      |      |             |      |      |      |      |      |                         |     |    |     |             |     |     |     |
| Capacitance(μF)         |  |   |                 |                                   |                    |                                  |                    |                                   |                 |                                    |  |  |  |  |   |      |      |      |      |      |            |      |      |      |      |      |          |      |      |      |      |      |             |      |      |      |      |      |                         |     |    |     |             |     |     |     |
| 1                       | 0.50                                   | 1.00  | 1.20            | 1.30                              | 1.50               |                                  |                    |                                   |                 |                                    |  |  |  |  |   |      |      |      |      |      |            |      |      |      |      |      |          |      |      |      |      |      |             |      |      |      |      |      |                         |     |    |     |             |     |     |     |
| 2.2 to 6.8              | 0.65                                   | 1.00  | 1.20            | 1.30                              | 1.50               |                                  |                    |                                   |                 |                                    |  |  |  |  |   |      |      |      |      |      |            |      |      |      |      |      |          |      |      |      |      |      |             |      |      |      |      |      |                         |     |    |     |             |     |     |     |
| 10 to 82                | 0.80                                   | 1.00  | 1.20            | 1.30                              | 1.50               |                                  |                    |                                   |                 |                                    |  |  |  |  |   |      |      |      |      |      |            |      |      |      |      |      |          |      |      |      |      |      |             |      |      |      |      |      |                         |     |    |     |             |     |     |     |
| 100 to 1000             | 0.80                                   | 1.00  | 1.10            | 1.15                              | 1.20               |                                  |                    |                                   |                 |                                    |  |  |  |  |   |      |      |      |      |      |            |      |      |      |      |      |          |      |      |      |      |      |             |      |      |      |      |      |                         |     |    |     |             |     |     |     |
| Ambient Temperature(°C) | 105                                    | 85  | 65≥             |                                   |                    |                                  |                    |                                   |                 |                                    |  |  |  |  |   |      |      |      |      |      |            |      |      |      |      |      |          |      |      |      |      |      |             |      |      |      |      |      |                         |     |    |     |             |     |     |     |
| Coefficient             | 1.0                                    | 1.7   | 2.1             |                                   |                    |                                  |                    |                                   |                 |                                    |  |  |  |  |   |      |      |      |      |      |            |      |      |      |      |      |          |      |      |      |      |      |             |      |      |      |      |      |                         |     |    |     |             |     |     |     |

9. Diagram of dimensions. :unit mm

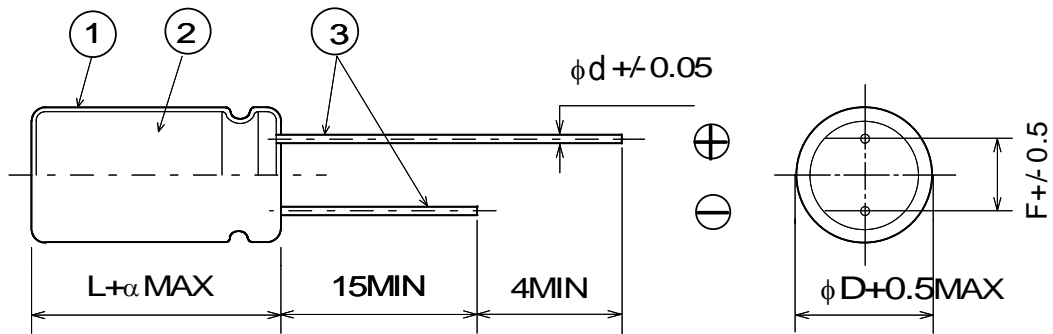

◆Table-2

|          |  |     |     |     |     |       |     |      |
|----------|--|-----|-----|-----|-----|-------|-----|------|
| $\phi D$ | 4  | 5   | 6.3 | 8X5 | 8X7 | 8X7.5 | 8X9 | 10X9 |
| $\phi d$ | 0.45                                     |     |     |     |     |       | 0.6 |      |
| F        | 1.5                                      | 2.0 | 2.5 | 2.5 | 3.5 | 3.5   | 3.5 | 5.0  |
| $\alpha$ | L=7 : $\alpha=1.0$<br>L=5 : $\alpha=1.5$ |     |     | 1.5 | 1.0 |       | 2.0 |      |

◆Table-3

|   |           |            |
|---|-----------|------------|
| ① | Sleeve    | P.E.T      |
| ② | Case      | Aluminum   |
| ③ | Lead Wire | Tin plated |

◆Table-4 Standard size, Maximum permissible ripple current

Size φDXL(mm), Ripple Current(mA r.m.s./105°C,120Hz)

| WV<br>Cap<br>(μF) | 6.3   |        | 10    |        | 16    |        | 25    |        |
|-------------------|-------|--------|-------|--------|-------|--------|-------|--------|
|                   | Size  | Ripple | Size  | Ripple | Size  | Ripple | Size  | Ripple |
| 10                |       |        |       |        |       |        | 4X5   | 18     |
| 12                |       |        |       |        |       |        |       |        |
| 15                |       |        |       |        |       |        | 4X7   | 35     |
| 18                |       |        |       |        | 4X5   | 20     |       |        |
| 22                |       |        | 4X5   | 22     | 4X7   | 40     | 5X5   | 42     |
| 27                | 4X5   | 25     |       |        |       |        | 5X7   | 57     |
| 33                |       |        | 4X7   | 43     | 5X5   | 45     |       |        |
| 39                |       |        |       |        | 5X7   | 65     |       |        |
| 47                | 4X7   | 47     | 5X5   | 48     |       |        | 6.3X5 | 65     |
| 56                | 5X5   | 50     | 5X7   | 68     |       |        | 6.3X7 | 85     |
| 68                |       |        |       |        | 6.3X5 | 70     |       |        |
| 82                | 5X7   | 75     |       |        |       |        | 8X5   | 100    |
| 100               |       |        | 6.3X5 | 75     | 6.3X7 | 95     | 8X7   | 112    |
| 120               | 6.3X5 | 80     | 6.3X7 | 100    | 8X5   | 110    |       |        |
| 150               |       |        |       |        | 8X7   | 125    | 8X7.5 | 140    |
| 180               | 6.3X7 | 110    | 8X5   | 120    |       |        |       |        |
| 220               | 8X5   | 125    | 8X7   | 160    | 8X7.5 | 170    | 8X9   | 190    |
| 270               | 8X7   | 165    |       |        |       |        |       |        |
| 330               |       |        | 8X7.5 | 180    | 8X9   | 195    | 10X9  | 450    |
| 390               |       |        |       |        |       |        |       |        |
| 470               | 8X7.5 | 190    | 8X9   | 210    | 10X9  | 460    |       |        |
| 560               | 8X9   | 230    |       |        |       |        |       |        |
| 680               |       |        | 10X9  | 470    |       |        |       |        |
| 1000              | 10X9  | 480    |       |        |       |        |       |        |

| WV<br>Cap<br>(μF) | 35    |        | 50    |        |
|-------------------|-------|--------|-------|--------|
|                   | Size  | Ripple | Size  | Ripple |
| 1                 |       |        | 4X5   | 8      |
| 2.2               |       |        | 4X5   | 11     |
| 3.3               |       |        | 4X5   | 14     |
| 4.7               |       |        | 4X7   | 23     |
| 6.8               | 4X5   | 17     | 5X5   | 25     |
| 10                | 4X7   | 28     | 5X7   | 30     |
| 12                | 5X5   | 34     | 6.3X5 | 37     |
| 15                |       |        |       |        |
| 18                | 5X7   | 48     | 6.3X7 | 50     |
| 22                |       |        | 8X5   | 62     |
| 27                | 6.3X5 | 58     |       |        |
| 33                |       |        | 8X7   | 75     |
| 39                | 6.3X7 | 76     |       |        |
| 47                | 8X5   | 80     |       |        |
| 56                | 8X7   | 105    | 8X7.5 | 115    |
| 68                |       |        |       |        |
| 82                |       |        | 8X9   | 160    |
| 100               | 8X7.5 | 125    |       |        |
| 120               |       |        | 10X9  | 315    |
| 150               | 8X9   | 180    |       |        |
| 180               |       |        |       |        |
| 220               | 10X9  | 360    |       |        |