

Part No.: ST-2L2B

UNIT: mm

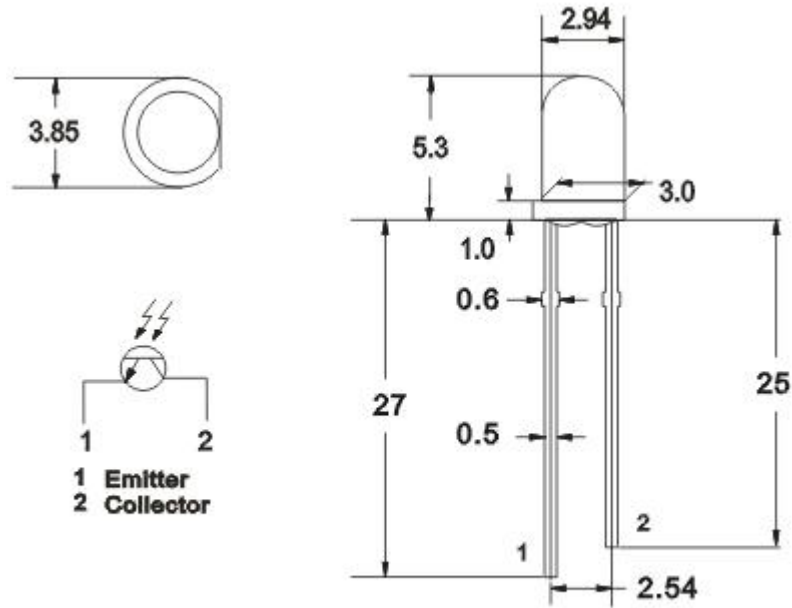

NOTE: TOLERANCE ± 0.5 mm

HUE:C

Parameter	Symbol	MIN.	TYP.	MAX.	UNIT	TEST CONDITION
Collector dark current	I_{CEO}			100	nA	$V_{CE}=20V$ $H=0mW/cm^2$
C-E Saturation Voltage	$V_{CE(Sat)}$			0.2	V	$I_C=2mA$ $I_B=100uA$
Current gain	h_{FE}	800		1800	uA	$V_{CE}=5V$ $I_C=2mA$
Rise Time(10%to90%)	t_r		15		uS	$V_{CE}=5V$ $I_C=1mA$ $R_L=100ohms$
Fail Time(90%to10%)	t_f		15			
Wavelength of Peak Sensitivity	λ_p		940		nm	
Range of Spectral Bandwidth	$\lambda_{0.5}$	700		1100	nm	
Collector-Emitter Breakdown Voltage	V_{CEO}	30			V	$I_C=100uA$ $I_B=0$
Emitter-Collector Breakdown Voltage	V_{ECO}	6.5				
Collector Current	I_C		20		mA	
C-Power dissipation	P_C		75		mW	
Collector-base Capacitance	C_{CB}	5.4	6.4	7.4	PF	$f=1MHZ$ $V_{CB}=3V$

■ ABSOLUTE MAXIMUM RATINGS: ($T_a=25^\circ C$)

■ OPERATING TEMPERATURE: $-25^\circ C$ TO $+85^\circ C$

■ LEAD SOLDERING TEMPERATURE: $260^\circ C$ FOR 5 SECONDS