

新品 变更

# 产品规格书

## SPECIFICATION FOR APPROVAL

产品名称  
Product Name: 石英晶体谐振器

产品型号  
Product Type: M49/SL-SMD

标称频率  
Nominal Freq: 16.000000 MHz

明德亨料号  
MDH P/N: 2.5.1.160001208

客户料号  
Customer P/N:

客户承认  
Approved By Customer

签章  
Signature:

日期  
Date:

Date: 2018年9月22日

批准	审核	拟制
Accepted	Checked	Issued
黄屹	乔润国	马赛



烟台明德亨电子科技有限公司

MDH Technology Co., Ltd

ADD: 中国山东烟台开发区黑龙江路6号

No.6 Heilongjiang Road Yantai Development Zone, Shandong, China

TEL: 86-535-6372640

FAX: 86-535-6394876

E-Mail: [dynamic@public.vtptt.sd.cn](mailto:dynamic@public.vtptt.sd.cn)<http://www.mingdeheng.com>

## Revision Record

VER	修订日	项目	内容	备注
	Rev. Date	Items	Contents	Remarks
01	2018-9-22	Issue		

M49/SL-SMD QUARTZ CRYSTAL UNIT	MDH P/N	2.5.1.160001208		
	REV.	01	PAGE	3/13

CONTENT

NO.	ITEM	PAGE
1	石英晶体一般规格及特性 Product specification and features	4
2	石英晶体外观尺寸及印字 Product outline dimension and marking	5
3	石英晶体内部结构 Product internal structure	6
4	石英晶体之可靠性 Product reliability	7-10
5	生产商及产地说明 Manufacturer and origin	11-13

M49/SL-SMD QUARTZ CRYSTAL UNIT	MDH P/N	2.5.1.160001208		
	REV.	01	PAGE	4/13

1. 石英晶体产品规格及特性 / Product specification and features

1.1 一般特性 / General characteristics

标称频率 Nominal frequency	16.000000	MHz
振动模式 Overtone order	Fundamental	
型号 Type	M49/SL-SMD	
动作温度 Operating temperature	-20~70	°C
保存温度 Storage temperature	-40~85	°C

1.2 电气特性 / Electric characteristics

调整频差(+25°C基准) Adjustment tolerance: (at+25°C)	±10	ppm
温度频差 Tolerance over the temperature:	±30	ppm
负载 Load capacitance	12	pF
测试仪器 Measure Instrument	S&A 250B	
激励功率 Drive level	100	μw
等效电阻 Equivalent resistance	60	Ω max
分布电容 (C0) Shut capacitance	5	pF
绝缘阻抗 Insulation resistance	500 MΩ Min	100VDC±15VDC
老化率 Aging	±5	PPM/Year

1.3 其它特性 / Other characteristics

SPDB	<-3	dB	(以标称频率为基准)
------	-----	----	------------

2. 外形尺寸、外观 / Outline dimensions、Appearances

2.1 产品外形尺寸(mm) / Product outline dimension(mm)

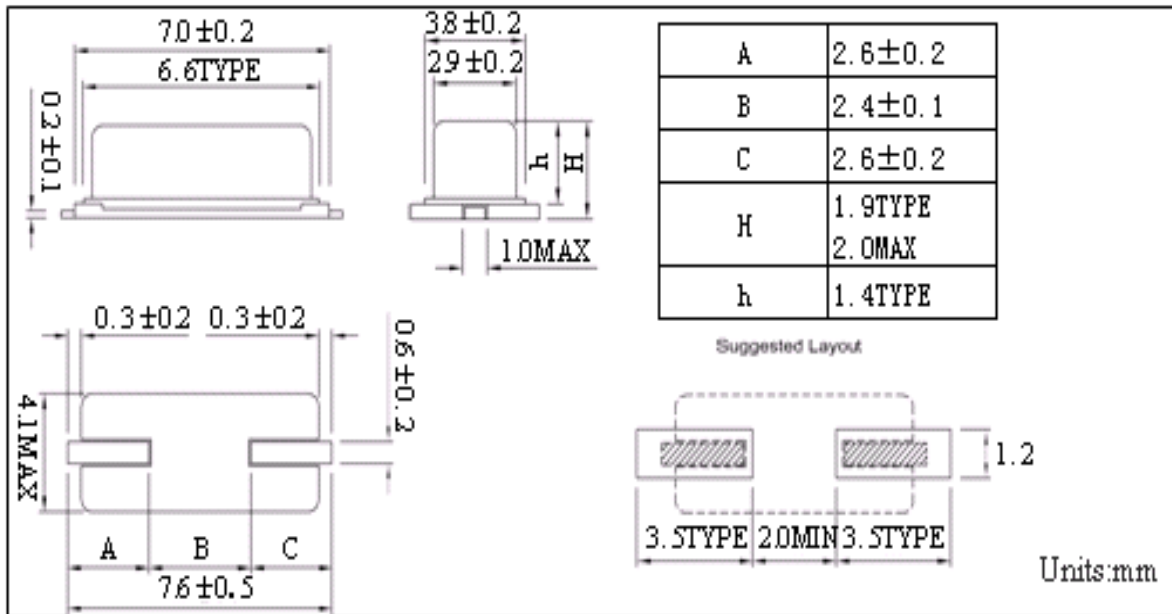

标准引线长度 (A+B+C=7.6)

2.2 印字 Marking

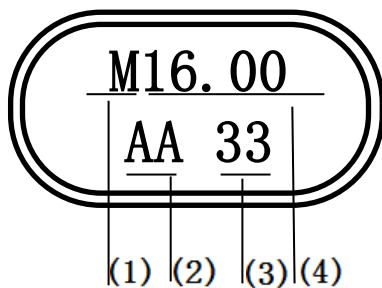

- Remarks: ① 公司代码 / Company code  
 ② 年度代码 / Year code  
 ③ 月份代码 / Month code (table-1)  
 ④ 频率 / Frequency

Table-1:

Month	Jan.	Feb.	Mar.	Apr.	May.	Jun.	Jul.	Aug.	Sep.	Oct.	Nov.	Dec.
Code	A	B	C	D	E	F	G	H	J	K	L	M

## 3. 内部构造图 / Product internal structure

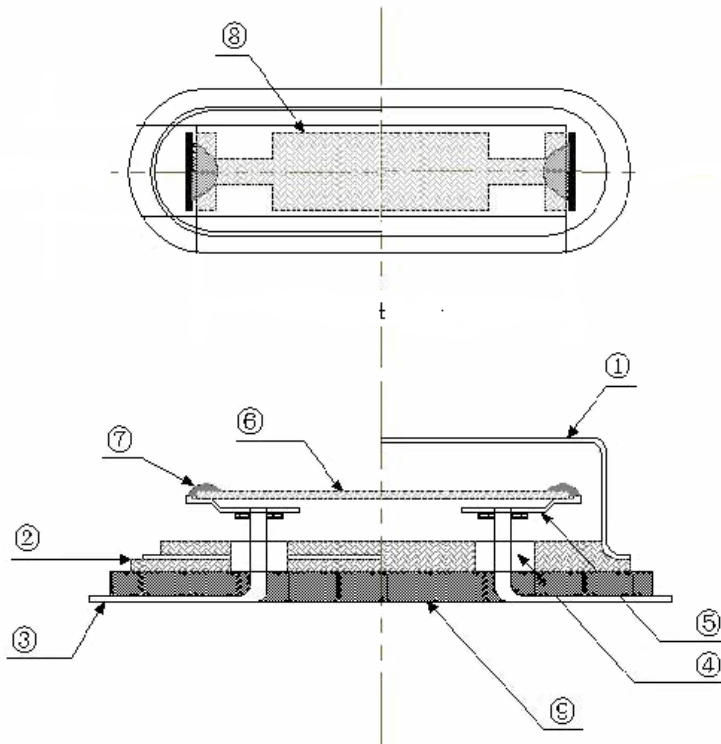

No	名称	材料	颜色	Supplier	Remark
	Description	Material	Color		
①	外壳/ Can	Nickel Silver	银白	Huaxun (China)	
②	底板/ Base	Fe	银白	Senzhong (China)	
③	引线/ Lead	Kovar	银白	Senzhong (China)	
④	玻璃绝缘子/ Glass	Glass	褐色	Senzhong (China)	
⑤	簧片/ Supporter	Cu、Zn、Ni	银白	Senzhong (China)	
⑥	晶片/ Blank	SiO <sub>2</sub>	透明	Gangnan (China)	
⑦	银胶/ Epoxy	Ag&resin	银白	Three Bond (Japan)	
⑧	电极/ Electrode	Ag	银白	Yinxin (China)	
⑨	绝缘垫片/ Insulator	PPA	黑色	Gangshan (China)	

## 4. 石英晶体之可靠性 / Product reliability

项目 (Item)	条件 (Condition)	结果 (Result)
A.1	耐低温性 (耐寒性) 测试 (Cold resistance)	(I)
	Stored at $-40\pm 5^{\circ}\text{C}$ for $500\pm 2$ hrs then $25\pm 2^{\circ}\text{C}$ 1~2 hrs before testing	
A.2	耐高温性 (耐热性) 测试 (Heat resistance)	(I)
	Stored at $85\pm 5^{\circ}\text{C}$ for $500\pm 2$ hrs then $25\pm 2^{\circ}\text{C}$ 1~2 hrs before testing	
A.3	盐雾测试 (Salt Mist Test)	(I)
	将温度 $35^{\circ}\text{C}\pm 2^{\circ}\text{C}$ 之盐水 (盐份浓度5%), 喷向石英晶体48小时 $\pm 2$ 小时, 再用清水洗净。 Spray the $35^{\circ}\text{C}\pm 2^{\circ}\text{C}$ salt water (salt density 5%) to crystal for $48\pm 2$ hrs, then clean by water	
A.4	耐湿热性 (Humidity Resistance Result)	(I)
	稳态温度: $60\pm 2^{\circ}\text{C}$ ; 湿度: 90~95%RH; 时间: 500h; Steady temperature: $60\pm 2^{\circ}\text{C}$ ; humidity: 90~95%RH; time:500h	
A.5	撞击测试 (Mechanical Shock)	(I)
	$14700\text{m/S}^2$ 0.5sec 5times in each of 6 direction	
A.6	老化 (Aging)	(I)
	Stored at $85\pm 3^{\circ}\text{C}$ for $720\pm 12$ Hrs then $25\pm 2^{\circ}\text{C}$ 1~2 Hrs before testing Stored at $25\pm 2^{\circ}\text{C}$ for $1\pm 0.03$ year	
A.7	气密性 (Leakage)	(VI)
	细漏Fine leak: Helium leak test *JIS C 60068-2-17	
A.8	温度循环 (Temperature Cycle)	(I)

-  $40^{\circ}\text{C}$  ~  $85^{\circ}\text{C}$ , Dwell 30Min, 100 cycles

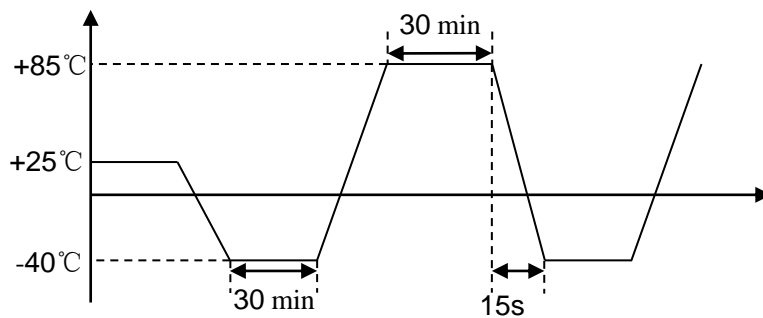

温度循环 (Temperature Cycle)

## 4.1 机械性能 / Mechanism characteristics

B.1	跌落测试 (Drop Test)	( I )
	Device are dropped from a height of 75 cm onto 20mm thickness stainless plate executing 3 times of random drops.	
B.2	耐振性 (Resistance of Vibration)	( I )
	Frequency: 10~55Hz, amplitude(total excursion): 1.5mm±15%, 3 direction (X, Y, Z) each 2 hr	
B.3	引线弯曲强度测试 (The Lead Terminal Bending Strength Test)	( I & II )
	固定本体, 在引线垂直方向负重250±10g, 然后弯曲90°, 慢慢恢复至原位置, 再向反方向弯曲90°, 再恢复到原位置。 Make the Crystal fixed, and loading the weight of 250±10g in the vertical direction of lead, and then bending it down to 90°, and slowly recover it to the original position, and then bending it down to 90° in the reverse direction, and recover it to the original position again.	
B.4	引线拉力测试 (Lead Pulling Test)	( I & II )
	引线端子下载重500±10g, 30±2秒 Lead terminal load weight is 500±10g, 30±2 Sec.	
B.5	端子弯曲强度测试(The Lead Terminal Bending Strength Test)	( I & II )
	固定本体, 引线弯折45°后, 慢慢恢复至原始位置。 Make the crystal fixed, after bending the lead down to 45°, slowly recover it to the original position.	

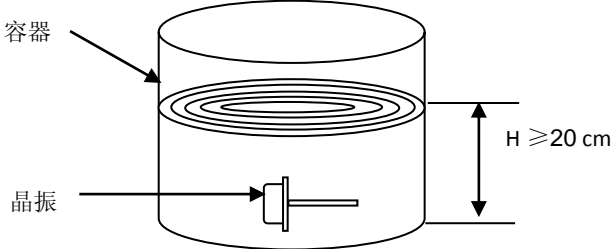

B.6	密封性测试 (Sealing Test) 石英晶体放于+85°C±5°C之温水中浸5分钟, 温水水量覆盖晶体约20cm. Dip Crystal in the water with the temperature of +85°C±5°C for 5 minutes, and the water will cover about 20cm of Crystal.	(IV)
		
B.7	耐焊接热 (手工) Resistance to soldering heat (Hand soldering method) 温度: 370~400°C; 时间: 3~4秒; 次数: 2次; 烙铁功率: 60W/Min Temperature: 370~400°C; Time: 3~4sec; Frequency: 2 times; Soldering iron: 60W/Min	(I)
B.8	可焊性试验 (Solderability) 240±2°C, 3±0.5sec	(III)
B.9	耐焊接热 (Reflow) Resistance to soldering heat (Reflow) 260±5°C; 10S; 4Times	(I)

TBMP. (°C)

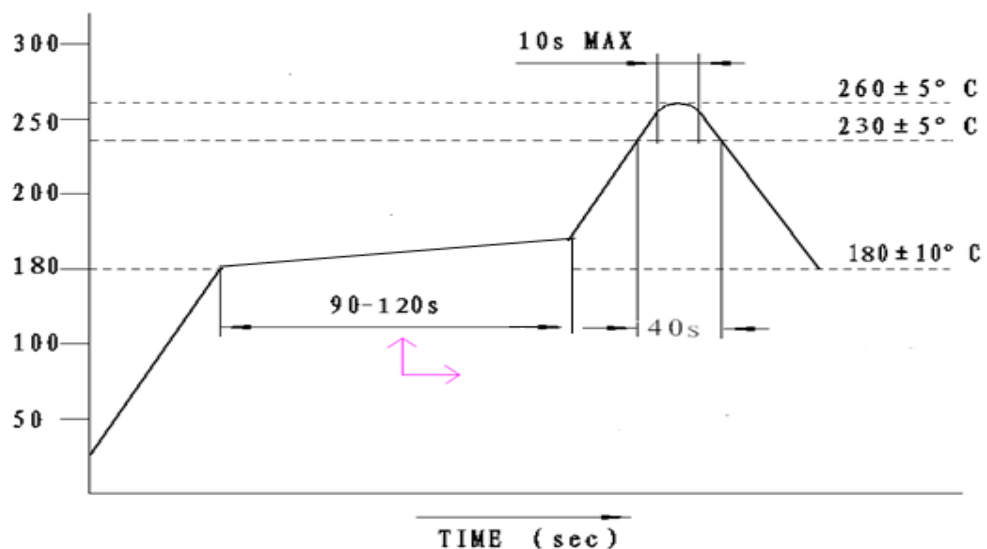

B.10	抗基板弯曲性 (The Board Bendability)	( I & II )
	依据EIAJRCX-0104/101, 变形量: 3mm Comply with EIAJRCX-0104/101, deformation degree: 3mm 时间(Time): 5±1秒(Sec)、1次(1 Time)	
B.11	端子强度	( I & V ) 满足B.6项
	按上图的箭头方向使用R0.5的压力棒, 在部品中央部分施加5±1N(0.51±0.1Kgf)的静载荷并保持10±1S秒钟。 Use R0.5 pressure stick following the arrowhead direction, give 5±1N(0.51±0.1Kgf)dead load at the center of crystal and keep for 10±1sec.	
B.12	静荷重 (Static Load)	( I & V ) 满足B.6项
	石英晶体静态荷重3.3N以上。 The Static Load of Crystal is above 3.3N.	

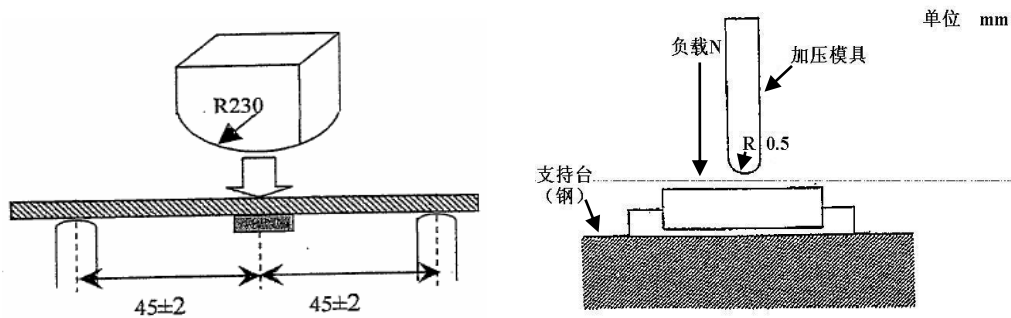

项目 Item	结果编号 Result NO	规格要求 Specification Requirements
1	( I )	频率变化 $\leq \pm 10\text{ppm}$ ; Rs符合规格要求 Change of Frequency $\rightarrow \pm 10\text{ppm}$ ; Rs could meet the requirements of Specification.
2	( II )	引线无折断, 在10倍放大镜下观察玻璃体无裂纹 The lead is no broken, the Glass is no crackle under the observation of 10 times Magnifier.
3	( III )	上锡覆盖率高于95% The covering rate of Tin-plating is more than 95%.
4	( IV )	无气泡在晶体表面沉淀或冒出水面, 绝缘阻抗 500 M $\Omega$ Min 100VDC $\pm$ 15VDC There is no bubbles after the Crystal is dipped in the water Insulation Resistance: 500 M $\Omega$ Min 100VDC $\pm$ 15VDC
5	( V )	在10倍放大镜下观察石英晶体无裂纹 The Crystal is no crackle under the observation of 10 times Magnifier.
6	( VI )	5*10 <sup>-9</sup> Pa.m <sup>3</sup> /s Max

## 5. 生产商及产地说明 / Manufacturer and origin

生产商: 烟台明德亨电子科技有限公司

Manufacturer: MDH Technology Co., Ltd

工厂/制造所在地: 山东省烟台开发区黑龙江路6号Address: NO.6 Heilongjiang Rd, Yantai development zone, Shandong产品名称: 石英晶体谐振器Product name: Quartz Crystal Resonator产品型号: M49/SL-SMD 16.000000 MHzProduct type: M49/SL-SMD 16.000000 MHz包装方式: 纸箱 38cm×37cm×37cm (±1.5cm)Package: Paper carton 38cm×37cm×37cm (±1.5cm)

标准包装 Standard package	SHIPPING MARK		标 签 Label
外包装 38×37× 37cm 如图P13- (2)	每箱 30000pcs (10小盒)	客户名称 订单号 客户料号 规格 数量 发货日期 装箱编号 产地	客户名称: ***** 订单号: XXXXX 客户料号: ##### 规格: M49/SL-SMD 27MHz9PF 数量: 3000pcs 发货单位: 烟台明德亨电子 发货日期: 2007.01.05 装箱编号: XX-X 产地: Made in China
内包装 33.3× 33.3× 3.2cm如图 P13-(1)	每盘 3000 pcs	料 号 型 号 规 格 出货批号 数 量 每小盒1盘 每盘3000pcs	料号: ##### 型号: M49/SL-SMD 规格: 27MHz9PF LOT No.: 070105A-01 数量: 3000pcs

5.1 包装规格 Package specification

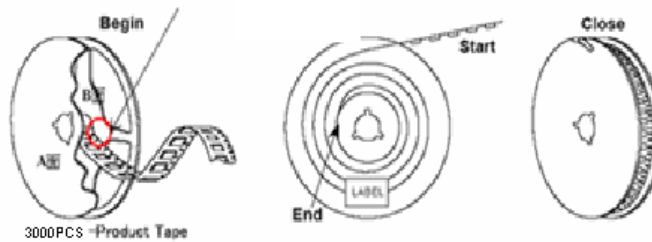
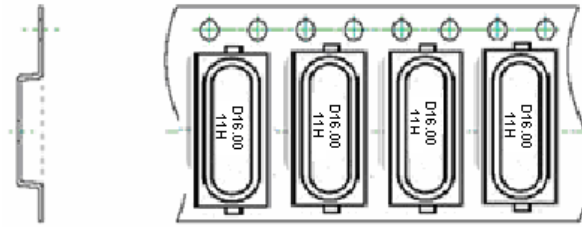

3000PCS -Product Tape

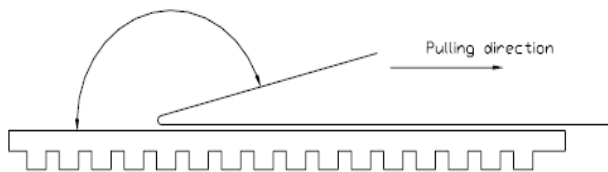

It has to between 0.1N to 0.7N under following condition.

Pulling direction: 165° to 180°

Pulling Speed : 300mm/min

Otherwise unless specified

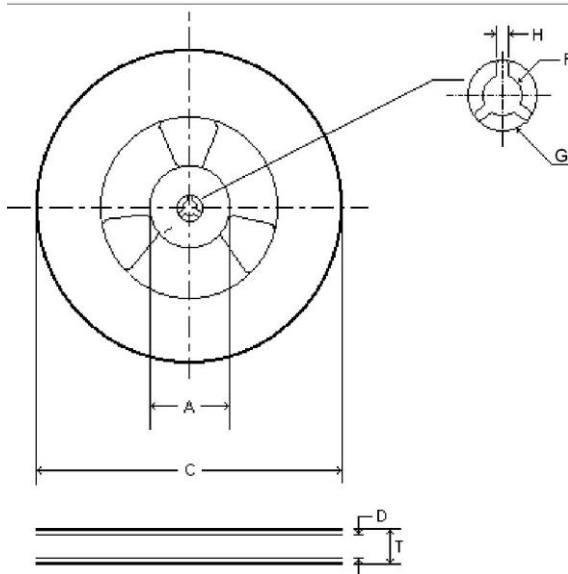
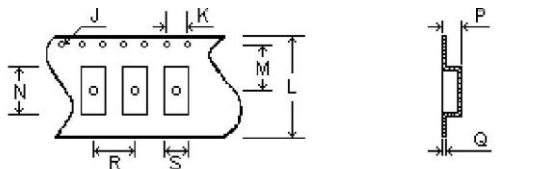

Tape&Reel		Carrier	
NO.	Dimmension	NO.	Dimmension
A	100±1.0mm	J	Φ 1.5mm
C	330±2.0mm	K	4.0±0.1mm
D	16.4±1.0mm	L	16.0±0.3mm
T	20.4±0.5mm	M	7.5±0.1mm
F	13.0±0.2mm	N	9.4±0.1mm
G	20.2mm MIN	P	2.5±0.1mm
H	1.5mm MIN	Q	0.3±0.05mm
		R	8.0±0.1mm
		S	4.4±0.1mm

5.2 包装规格 Package specification

1. 每盘数量Qty/reel: 3000pcs
2. 小盒数量Qty/box: 3000pcs (1盘)
3. 外箱数量Qty/carton: 30000pcs (10小盒)
4. 净重NW: 10KGS; 毛重GW: 12.5KGS

料号: #####  
 型号: M49/SL-SMD  
 规格: 27.000MHz9PF  
 LOT No.: 120428A-01  
 数量: 3000pcs

RoHS

料号: #####  
 型号: M49/SL-SMD  
 规格: 27.000MHz9PF  
 LOT No.: 120428A-01  
 数量: 3000pcs

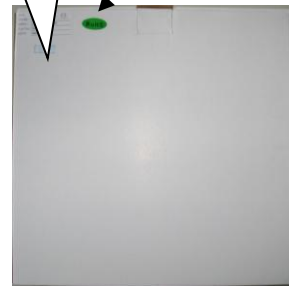
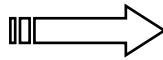

33.3×33.3×3.2cm (±0.5cm)

1CM左右泡沫板, 缓冲及抗震作用

客户名称: \*\*\*\*\*  
 订单号: XXXXX  
 客户料号: #####  
 规格: M49/SL-SMD 27MHz9PF  
 数量: 30000pcs  
 发货单位: 烟台明德亨电子科技有限公司  
 发货日期: 2007.01.05  
 装箱编号: XX-X  
 产地: Made in China

RoHS

