

ISO308x Isolated 5-V Full- and Half-Duplex RS-485 Transceivers

1 Features

- Meets or Exceeds TIA/EIA RS-485 Requirements
- Signaling Rates up to 20 Mbps
- 1/8 Unit Load – Up to 256 Nodes on a Bus
- Thermal Shutdown Protection
- Low Bus Capacitance – 16 pF (Typical)
- 50 kV/ μ s Typical Transient Immunity
- Fail-safe Receiver for Bus Open, Short, Idle
- 3.3-V Inputs are 5-V Tolerant
- Bus-Pin ESD Protection
 - 12-kV HBM Between Bus Pins and GND2
 - 6-kV HBM Between Bus Pins and GND1
- Safety-Related Certifications:
 - 4000- V_{PK} Basic Insulation, 560 V_{PK} V_{IORM} per DIN V VDE V 0884-10 (VDE V 0884-10): 2006-12 and DIN EN 61010-1
 - 2500 V_{RMS} Isolation per UL 1577
 - 4000 V_{PK} Isolation per CSA Component Acceptance Notice 5A and IEC 60950-1

2 Applications

- Security Systems
- Chemical Production
- Factory Automation
- Motor and Motion Control
- HVAC and Building Automation Networks
- Networked Security Stations

3 Description

The ISO3080 and ISO3086 devices are isolated full-duplex differential line drivers and receivers while the ISO3082 and ISO3088 devices are isolated half-duplex differential line transceivers for TIA/EIA 485/422 applications.

These devices are ideal for long transmission lines because the ground loop is broken to allow for a much larger common-mode voltage range. The symmetrical isolation barrier of the device is tested to provide 2500 V_{RMS} of isolation for 60 s per UL 1577 between the bus-line transceiver and the logic-level interface.

Any cabled I/O can be subjected to electrical noise transients from various sources. These noise transients can cause damage to the transceiver and/or nearby sensitive circuitry if they are of sufficient magnitude and duration. These isolated devices can significantly increase protection and reduce the risk of damage to expensive control circuits.

The ISO3080, ISO3082, ISO3086, and ISO3088 device are qualified for use from -40°C to $+85^{\circ}\text{C}$.

Device Information⁽¹⁾

PART NUMBER	PACKAGE	BODY SIZE (NOM)
ISO3080	SOIC (16)	10.30 mm x 7.50 mm
ISO3082		
ISO3086		
ISO3088		

(1) For all available packages, see the orderable addendum at the end of the data sheet.

ISO3080, IOS3086 Function Diagram

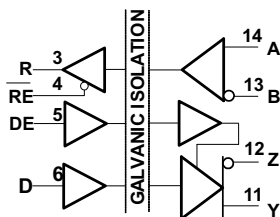

ISO3082, IOS3088 Function Diagram

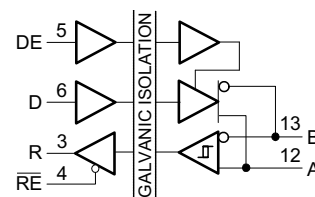

Table of Contents

1 Features	1	8 Detailed Description	17
2 Applications	1	8.1 Overview	17
3 Description	1	8.2 Functional Block Diagrams	17
4 Revision History	2	8.3 Feature Description	18
5 Pin Configuration and Functions	4	8.4 Device Functional Modes	18
6 Specifications	5	9 Application and Implementation	20
6.1 Absolute Maximum Ratings	5	9.1 Application Information	20
6.2 ESD Ratings	5	9.2 Typical Application	20
6.3 Recommended Operating Conditions	5	10 Power Supply Recommendations	22
6.4 Thermal Information	6	11 Layout	22
6.5 Insulation Specifications	6	11.1 Layout Guidelines	22
6.6 Safety-Related Certifications	6	11.2 Layout Example	23
6.7 Safety Limiting Values	7	12 Device and Documentation Support	24
6.8 Electrical Characteristics: Driver	7	12.1 Documentation Support	24
6.9 Electrical Characteristics: Receiver	8	12.2 Related Links	24
6.10 Supply Current	9	12.3 Receiving Notification of Documentation Updates	24
6.11 Switching Characteristics: Driver	9	12.4 Community Resources	24
6.12 Switching Characteristics: Receiver	9	12.5 Trademarks	24
6.13 Insulation Characteristics Curves	10	12.6 Electrostatic Discharge Caution	24
6.14 Typical Characteristics	11	12.7 Glossary	25
7 Parameter Measurement Information	13	13 Mechanical, Packaging, and Orderable Information	25

4 Revision History

NOTE: Page numbers for previous revisions may differ from page numbers in the current version.

Changes from Revision H (December 2015) to Revision I

Page

• Changed the L(I01) and L(I02) parameters to external clearance and external creepage, respectively	6
• Changed the V_{PR} parameter to apparent charge	6
• Switched the R and D pins of the master device in the <i>Typical RS-485 Network With Full-Duplex Transceivers</i> figure	20
• Added the <i>Receiving Notification of Documentation Updates</i> section	24
• Changed the <i>Electrostatic Discharge Caution</i> statement	24

Changes from Revision G (July 2015) to Revision H

Page

• Changed the CDM value in <i>ESD Ratings</i> From: ± 200 To: ± 1000	5
• Changed the MON value of L(I01) in <i>Insulation and Safety-Related Package Characteristics</i> From: 8.34 To: 8 mm	6
• Changed the MON value of L(I02) in <i>Insulation and Safety-Related Package Characteristics</i> From: 8.1 To: 8 mm	6
• Moved the last list item " Routing the high-speed traces..." to the second list items in <i>Layout Guidelines</i> section	22

Changes from Revision F (May 2015) to Revision G

Page

• Deleted "Rated mains voltage $\leq 400 V_{RMS}$ " from <i>IEC 60664-1 Ratings Table</i>	6
• Changed "Maximum case temperature" To: "Maximum safety temperature" in <i>Safety Limiting</i>	7
• Changed the <i>Layout Guidelines</i> section	22

Changes from Revision E (September 2011) to Revision F **Page**

- Added *ESD Rating* table, *Thermal Information* table, *Feature Description* section, *Device Functional Modes*, *Application and Implementation* section, *Power Supply Recommendations* section, *Layout* section, *Device and Documentation Support* section, and *Mechanical, Packaging, and Orderable Information* section..... **1**
 - Changed *Features* list item From: IEC 60747-5-2 (VDE 0884, Rev. 2) To: DIN V VDE V 0884-10 (VDE V 0884-10):2006-12..... **1**
 - VDE standard changed to DIN V VDE V 0884-10 (VDE V 0884-10):2006-12..... **1**
 - Changed *IEC 60664-1 Ratings Table*. Basic isolation group SPECIFICATION entry From: IIIa To: II **6**
-

Changes from Revision D (January 2011) to Revision E **Page**

- Changed *Features* list item From: 16 kV HBM To: 12 kV HBM **1**
 - Changed ESD HBM spec value from ± 16 to ± 12 in *ESD Ratings* **5**
-

Changes from Revision C (October 2009) to Revision D **Page**

- Added T_{STG} row to the *Absolute Maximum Ratings* **5**
 - Added "Dynamic" conditions to *Recommended Operating Conditions* V_{ID} spec with reference to *ISO3086 Recommended Minimum Differential Input Voltage vs Signaling Rate*..... **5**
 - Changed for 3 V to 3.3 V in note 1 of the *Recommended Operating Conditions* table **5**
 - Changed File Number from '1698195' to '220991' in *Regulatory Information* **6**
 - Changed θ_{JA} from 212 ° C/W to 168 ° C/W in conditions statement for I_S spec.; and MAX current from 210 mA to 157 mA in *Safety Limiting*..... **7**
 - Deleted $V_I = V_{CCI}$ or 0 V from CMTI spec. Conditions statement. Added "Figure 13" in *Electrical Characteristics: Driver* ... **7**
 - Changed top row, UNIT column, split into 2 rows, top row μs and second row ns in *Switching Characteristics: Driver*..... **9**
 - Changed graph for " DW-16 θ_{JC} Thermal Derating Curve per IEC 60747-5-2 ", *Thermal Derating Curve*..... **10**
 - Added the *ISO3086 Recommended Minimum Differential Input Voltage vs Signaling Rate* graph..... **11**
 - Added note to bottom of first page of the *Parameter Measurement Information*..... **13**
 - Added Footnotes to the *Driver Function Table* and *Receiver Function Table* **18**
-

Changes from Revision B (December 2008) to Revision C **Page**

- Changed *Recommended Operating Conditions* table note From: For 3-V operation, V_{CC1} or V_{CC2} is specified from 3.15 V to 3.6V. To: For 3-V operation, V_{CC1} is specified from 3.15 V to 3.6V..... **5**
-

Changes from Revision A (June 2008) to Revision B **Page**

- Changed *Features* bullet From: 4000- V_{PEAK} Isolation, To: 4000- V_{PEAK} Isolation,, 560- V_{PEAK} V_{IORM} **1**
 - Added the CSA column to *Regulatory Information*..... **6**
-

Changes from Original (May 2008) to Revision A **Page**

- Deleted the CSA column from *Regulatory Information*. **6**
 - Changed the file number in the VDE column in *Regulatory Information* From: 40014131 To: 40016131 **6**
-

5 Pin Configuration and Functions

ISO3080 and ISO3086 DW Package
16-Pin SOIC
Top View

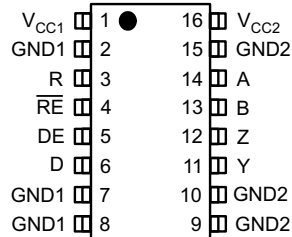

ISO3082 and ISO3088 DW Package
16-Pin SOIC
Top View

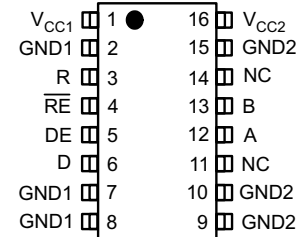

Pin Functions

NAME	PIN		I/O	DESCRIPTION
	ISO3080, ISO3086	ISO3082, ISO3088		
A	14	—	I	Receiver noninverting input on the bus-side
	—	12	I/O	Transceiver noninverting Input or output (I/O) on the bus-side
B	13	—	I	Receiver inverting Input on the bus-side
	—	13	I/O	Transceiver inverting input or output (I/O) on the bus-side
D	6	6	I	Driver input
DE	5	5	I	Enables (when high) or disables (when low or open) driver output of ISO308x
GND1	2	2	—	Ground connection for V _{CC1}
	7	7		
	8	8		
GND2	9	9	—	Ground connection for V _{CC2}
	10	10		
	15	15		
NC	—	11	—	No connect
	—	14		
R	3	3	O	Receiver output
\overline{RE}	4	4	I	Disables (when high or open) or enables (when low) receiver output of ISO308x
V _{CC1}	1	1	—	Power supply, V _{CC1}
V _{CC2}	16	16	—	Power supply, V _{CC2}
Y	11	—	O	Driver noninverting output
Z	12	—	O	Driver inverting output

6 Specifications

6.1 Absolute Maximum Ratings

See ⁽¹⁾.

			MIN	MAX	UNIT
V_{CC}	Input supply voltage ⁽²⁾	V_{CC1}, V_{CC2}	-0.3	6	V
V_O	Voltage at any bus I/O pin		-9	14	V
V_{IT}	Voltage input, transient pulse (through 100 Ω , see Figure 21)	A, B, Y, and Z	-50	50	V
V_I	Voltage input at any D, DE or \overline{RE} pin		-0.5	7	V
I_O	Receiver output current			± 10	mA
T_J	Maximum junction temperature			150	$^{\circ}\text{C}$
T_{stg}	Storage temperature		-65	150	$^{\circ}\text{C}$

- (1) Stresses beyond those listed under *absolute maximum ratings* may cause permanent damage to the device. These are stress ratings only and functional operation of the device at these or any other conditions beyond those indicated under *recommended operating conditions* is not implied. Exposure to absolute-maximum-rated conditions for extended periods may affect device reliability.
- (2) All voltage values except differential I/O bus voltages are with respect to network ground terminal and are peak voltage values.

6.2 ESD Ratings

			VALUE	UNIT	
$V_{(ESD)}$	Electrostatic discharge	Human body model (HBM), per ANSI/ESDA/JEDEC JS-001 ⁽¹⁾	Bus pins and GND1	± 6000	V
			Bus pins and GND2	± 12000	
			All pins	± 4000	
		Charged device model (CDM), per JEDEC specification JESD22-C101 ⁽²⁾	± 1000		

- (1) JEDEC document JEP155 states that 500-V HBM allows safe manufacturing with a standard ESD control process.
- (2) JEDEC document JEP157 states that 250-V CDM allows safe manufacturing with a standard ESD control process.

6.3 Recommended Operating Conditions

			MIN	TYP	MAX	UNIT
V_{CC1}	Logic-side supply voltage ⁽¹⁾		3.15		5.5	V
V_{CC2}	Bus-side supply voltage ⁽¹⁾		4.5	5	5.5	V
V_{OC}	Voltage at either bus I/O pin	A, B	-7		12	V
V_{IH}	High-level input voltage	D, DE, \overline{RE}	2		V_{CC}	V
V_{IL}	Low-level input voltage	D, DE, \overline{RE}	0		0.8	V
V_{ID}	Differential input voltage	A with respect to B	-12		12	V
		Dynamic (ISO3086)	See Figure 10			
R_L	Differential input resistance		54	60		Ω
I_O	Output current	Driver	-60		60	mA
		Receiver	-8		8	
T_A	Ambient temperature		-40		85	$^{\circ}\text{C}$

- (1) For 5-V operation, V_{CC1} or V_{CC2} is specified from 4.5 V to 5.5 V. For 3.3-V operation, V_{CC1} is specified from 3.15 V to 3.6 V.

6.4 Thermal Information

THERMAL METRIC ⁽¹⁾		ISO308x	UNIT	
		DW (SOIC)		
		16 PINS		
R _{θJA}	Junction-to-ambient thermal resistance	Low-K thermal resistance ⁽²⁾	168	°C/W
		High-K thermal resistance	79.6	
R _{θJC(top)}	Junction-to-case (top) thermal resistance		39.7	°C/W
R _{θJB}	Junction-to-board thermal resistance		44.7	°C/W
ψ _{JT}	Junction-to-top characterization parameter		11.8	°C/W
ψ _{JB}	Junction-to-board characterization parameter		44.0	°C/W
R _{θJC(bot)}	Junction-to-case (bottom) thermal resistance		—	°C/W

- (1) For more information about traditional and new thermal metrics, see the [Semiconductor and IC Package Thermal Metrics](#) application report.
- (2) Tested in accordance with the Low-K or High-K thermal metric definitions of EIA/JESD51-3 for leaded surface mount packages.

6.5 Insulation Specifications

PARAMETER	TEST CONDITIONS	VALUE	UNIT
GENERAL			
CLR	External clearance ⁽¹⁾	Shortest terminal-to-terminal distance through air	8 mm
CPG	External creepage ⁽¹⁾	Shortest terminal-to-terminal distance across the package surface	8 mm
DTI	Distance through the insulation	Minimum internal gap (internal clearance)	0.008 mm
CTI	Comparative tracking index	DIN EN 60112 (VDE 0303-11)	≥400 V
	Material group		II
	Overvoltage category	Rated mains voltage ≤ 150 V _{RMS}	I-IV
		Rated mains voltage ≤ 300 V _{RMS}	I-III
DIN V VDE V 0884-10 (VDE V 0884-10):2006-12⁽²⁾			
V _{IORM}	Maximum repetitive peak isolation voltage	AC voltage (bipolar)	560 V _{PK}
V _{IOTM}	Maximum transient isolation voltage	V _{TEST} = V _{IOTM} , t = 60 s (qualification); t = 1 s (100% production)	4000 V _{PK}
q _{pd}	Apparent charge ⁽³⁾	Method b1, V _{PR} = V _{IORM} × 1.5, 100% Production test with t = 1 s	≤5 pC
C _{IO}	Barrier capacitance, input to output ⁽⁴⁾	V _I = 0.4 sin(4E6πt)	2 pF
R _{IO}	Isolation resistance, input to output ⁽⁴⁾	V _{IO} = 500 V, T _A = 25°C, all pins on each side of the barrier tied together creating a 2-terminal device	>10 ¹² Ω
		V _{IO} = 500 V at T _S = 150°C	>10 ⁹ Ω
	Pollution degree		2
	Climatic category		40/125/21

- (1) Creepage and clearance requirements should be applied according to the specific equipment isolation standards of an application. Care should be taken to maintain the creepage and clearance distance of a board design to ensure that the mounting pads of the isolator on the printed-circuit board do not reduce this distance. Creepage and clearance on a printed-circuit board become equal in certain cases. Techniques such as inserting grooves and/or ribs on a printed circuit board are used to help increase these specifications.
- (2) This coupler is suitable for *basic electrical insulation* only within the maximum operating ratings. Compliance with the safety ratings shall be ensured by means of suitable protective circuits.
- (3) Apparent charge is electrical discharge caused by a partial discharge (pd).
- (4) All pins on each side of the barrier tied together creating a two-terminal device

6.6 Safety-Related Certifications

VDE	CSA	UL
Certified according to DIN V VDE V 0884-10 (VDE V 0884-10):2006-12	Approved under CSA Component Acceptance Notice 5A and IEC 60950-1	Recognized under UL 1577 Component Recognition Program
Basic insulation, 4000 V _{PK} Maximum transient overvoltage, 560 V _{PK} Maximum repetitive peak isolation voltage	4000 V _{PK} Isolation rating, 560 V _{PK} Basic working voltage per CSA 60950-1-07 and IEC 60950-1 (2nd Ed)	Single Protection, 2500 V _{RMS}
Certificate number: 40016131	Master contract number: 220991	File number: E181974

6.7 Safety Limiting Values

Safety limiting⁽¹⁾ intends to minimize potential damage to the isolation barrier upon failure of input or output circuitry. A failure of the I/O can allow low resistance to ground or the supply and, without current limiting, dissipate sufficient power to overheat the die and damage the isolation barrier, potentially leading to secondary system failures.

PARAMETER	TEST CONDITIONS	MIN	TYP	MAX	UNIT
I_S	Safety input, output, or supply current			286	mA
T_S	Safety temperature			150	°C

- (1) The safety-limiting constraint is the maximum junction temperature specified in the data sheet. The power dissipation and junction-to-air thermal impedance of the device installed in the application hardware determines the junction temperature. The assumed junction-to-air thermal resistance in the [Thermal Information](#) table is that of a device installed on a high-K test board for leaded surface-mount packages. The power is the recommended maximum input voltage times the current. The junction temperature is then the ambient temperature plus the power times the junction-to-air thermal resistance.

6.8 Electrical Characteristics: Driver

over recommended operating conditions (unless otherwise noted)

PARAMETER	TEST CONDITIONS	MIN	TYP	MAX	UNIT	
$ V_{OD} $	Differential output voltage magnitude	$I_O = 0$ mA, no load	3	4.3	V_{CC}	V
		$R_L = 54 \Omega$, See Figure 11	1.5	2.3		
		$R_L = 100 \Omega$ (RS-422), See Figure 11	2	2.3		
		V_{test} from -7 V to $+12$ V, See Figure 12	1.5			
$\Delta V_{OD} $	Change in magnitude of the differential output voltage	See Figure 11 and Figure 12	-0.2	0	0.2	V
$V_{OC(SS)}$	Steady-state common-mode output voltage	See Figure 13	1	2.6	3	V
$\Delta V_{OC(SS)}$	Change in steady-state common-mode output voltage	See Figure 13	-0.1		0.1	
$V_{OC(PP)}$	Peak-to-peak common-mode output voltage	See Figure 13		0.5		
I_I	Input current	D, DE, V_I at 0 V or V_{CC1}	-10		10	μ A
I_{OZ}	High-impedance state output current	ISO3082, ISO3088	See the receiver bias input current parameter			μ A
		ISO3080 ISO3086	V_Y or $V_Z = 12$ V, $V_{CC} = 0$ V or 5 V, DE = 0 V, Other input at 0 V		1	
		V_Y or $V_Z = -7$ V, $V_{CC} = 0$ V or 5 V, DE = 0 V, Other input at 0 V	-1			
I_{OS}	Short-circuit output current	V_A or V_B at -7 V, Other input at 0 V	-200		200	mA
		V_A or V_B at 12 V, Other input at 0 V				
CMTI	Common-mode transient immunity	See Figure 22 and Figure 23	25	50		kV/ μ s

6.9 Electrical Characteristics: Receiver

over recommended operating conditions (unless otherwise noted)

PARAMETER		TEST CONDITIONS	MIN	TYP	MAX	UNIT
$V_{IT(+)}$	Positive-going input threshold voltage	$I_O = -8 \text{ mA}$		-85	-10	mV
$V_{IT(-)}$	Negative-going input threshold voltage	$I_O = 8 \text{ mA}$	-200	-115		mV
V_{hys}	Hysteresis voltage ($V_{IT+} - V_{IT-}$)			30		mV
V_{OH}	High-level output voltage	$V_{ID} = 200 \text{ mV}$, $I_O = -8 \text{ mA}$, See Figure 17	3.3-V V_{CC1}	$V_{CC1} - 0.4$	3.1	V
			5-V V_{CC1}	4	4.8	
V_{OL}	Low-level output voltage	$V_{ID} = -200 \text{ mV}$, $I_O = 8 \text{ mA}$, See Figure 17	3.3-V V_{CC1}	0.15	0.4	V
			5-V V_{CC1}	0.15	0.4	
$I_{O(Z)}$	High-impedance state output current	$V_I = -7 \text{ to } 12 \text{ V}$, Other input = 0 V	-1		1	μA
I_I	Bus input current	V_A or $V_B = 12 \text{ V}$, Other input at 0 V		0.04	0.1	mA
		V_A or $V_B = 12 \text{ V}$, $V_{CC} = 0$, Other input at 0 V		0.06	0.13	
		V_A or $V_B = -7 \text{ V}$, Other input at 0 V	-0.1	-0.04		
		V_A or $V_B = -7 \text{ V}$, $V_{CC} = 0$, Other input at 0 V	-0.05	-0.03		
I_{IH}	High-level input current, \overline{RE}	$V_{IH} = 2 \text{ V}$	-10		10	μA
I_{IL}	Low-level input current, \overline{RE}	$V_{IL} = 0.8 \text{ V}$	-10		10	μA
R_{ID}	Differential input resistance	A, B	48			k Ω
C_D	Differential input capacitance	Test input signal is a 1.5-MHz sine wave with 1- V_{PP} amplitude. C_D is measured across A and B		7		pF
C_I	Input capacitance to ground	$V_I = 0.4 \sin(4E6\pi t)$		2		pF

6.10 Supply Current

over recommended operating condition (unless otherwise noted)

PARAMETER		TEST CONDITIONS		MIN	TYP	MAX	UNIT
I_{CC1}	Logic-side supply current	\overline{RE} at 0 V or V_{CC} , DE at 0 V or V_{CC1}	3.3-V V_{CC1}			8	mA
		\overline{RE} at 0 V or V_{CC} , DE at 0 V or V_{CC1}	5-V V_{CC1}			10	
I_{CC2}	Bus-side supply current	\overline{RE} at 0 V or V_{CC} , DE at 0 V, No load				15	mA

6.11 Switching Characteristics: Driver

over recommended operating conditions (unless otherwise noted)

PARAMETER		TEST CONDITIONS		MIN	TYP	MAX	UNIT	
t_{PLH} , t_{PHL}	Propagation delay	ISO3080/82	See Figure 14		0.7	1.3	μ s	
		ISO3086/88			25	45	ns	
PWD ⁽¹⁾	Pulse skew ($ t_{PHL} - t_{PLH} $)	ISO3080/82			20	200	ns	
		ISO3086/88			3	7.5		
t_r , t_f	Differential output signal rise and fall time	ISO3080/82			0.5	0.9	1.5	μ s
		ISO3086/88			7	15	ns	
t_{PZH} , t_{PZL}	Propagation delay, high-impedance-to-high-level output and high-impedance-to-low-level output	ISO3080/82		See Figure 15 and Figure 16 , DE at 0 V	50% V_O	2.5	7	μ s
		ISO3086/88			90% V_O	25	55	
t_{PHZ} , t_{PLZ}	Propagation delay, high-level-to-high-impedance output and low-level to high-impedance output	ISO3080/82		See Figure 15 and Figure 16 , DE at 0 V		95	225	ns
		ISO3086/88				25	55	

(1) Also known as pulse skew

6.12 Switching Characteristics: Receiver

over recommended operating conditions (unless otherwise noted)

PARAMETER		TEST CONDITIONS		MIN	TYP	MAX	UNIT
t_{PLH} , t_{PHL}	Propagation delay	See Figure 18			90	125	ns
				PWD ⁽¹⁾	Pulse width distortion $ t_{PHL} - t_{PLH} $	4	
t_r , t_f	Output signal rise and fall time					1	
t_{PHZ} , t_{PZH}	Propagation delay, high-level-to-high-impedance output and high-impedance-to-high-level output	See Figure 19 , DE at 0 V				22	ns
t_{PZL} , t_{PLZ}	Propagation delay, high-impedance-to-low-level output and low-level-to-high-impedance output	See Figure 20 , DE at 0 V				22	ns

(1) Also known as pulse skew.

6.13 Insulation Characteristics Curves

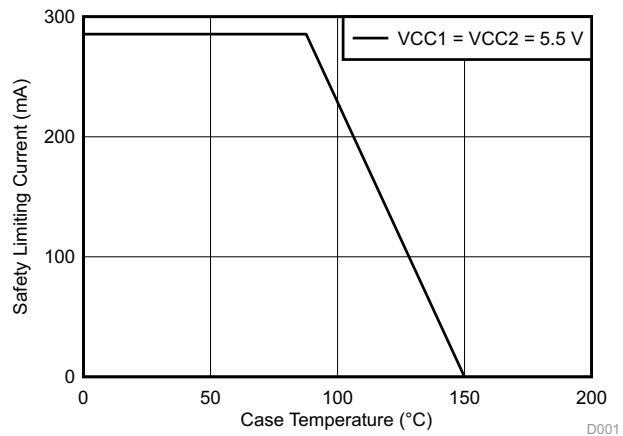
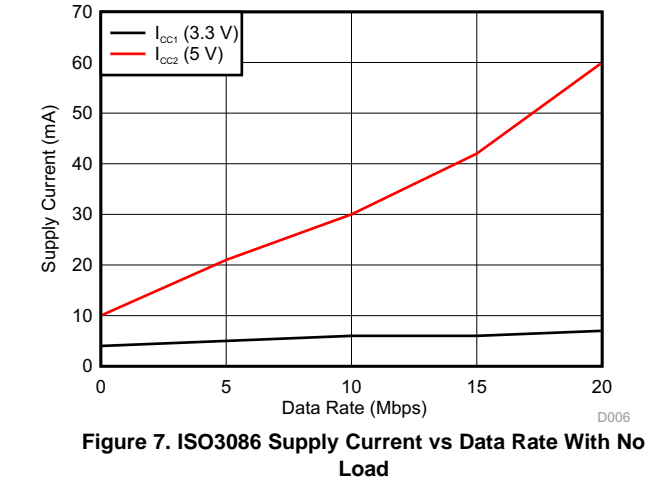
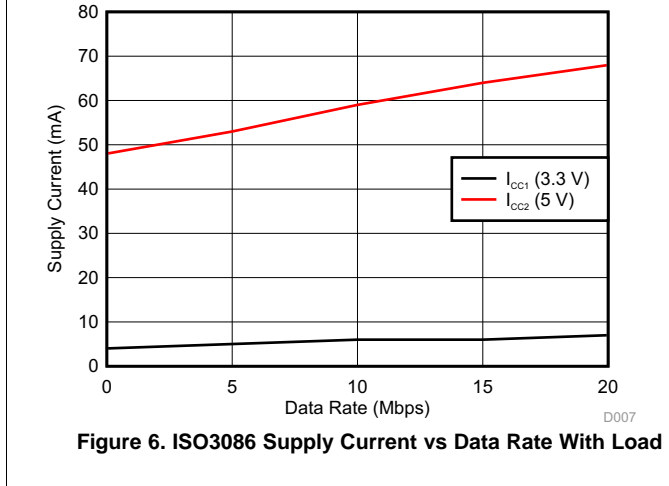
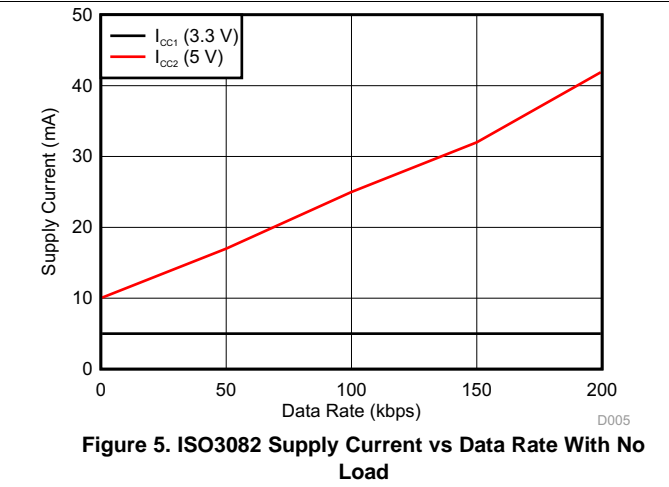
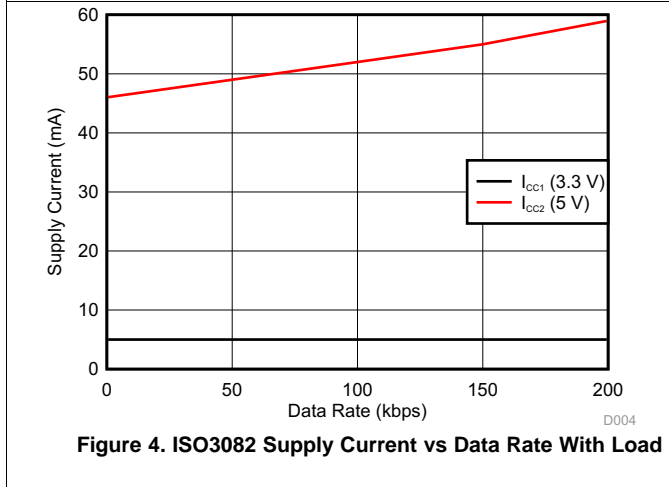
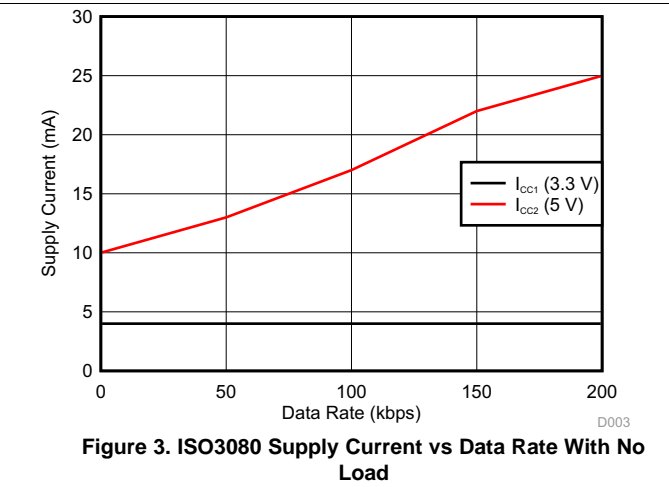
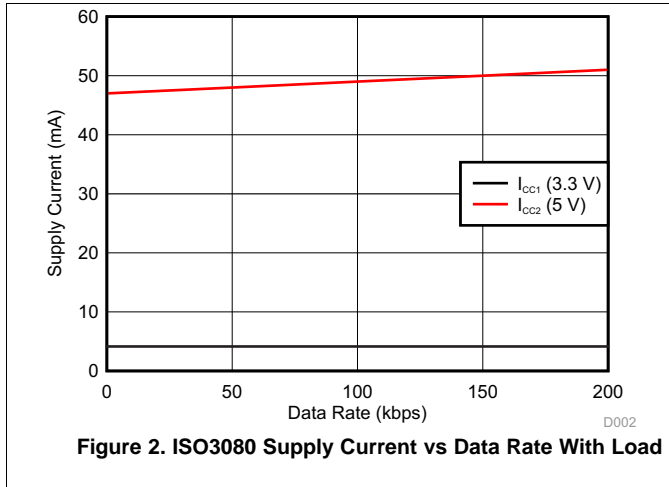

Figure 1. Thermal Derating Curve for Limiting Current per VDE

6.14 Typical Characteristics



Typical Characteristics (continued)

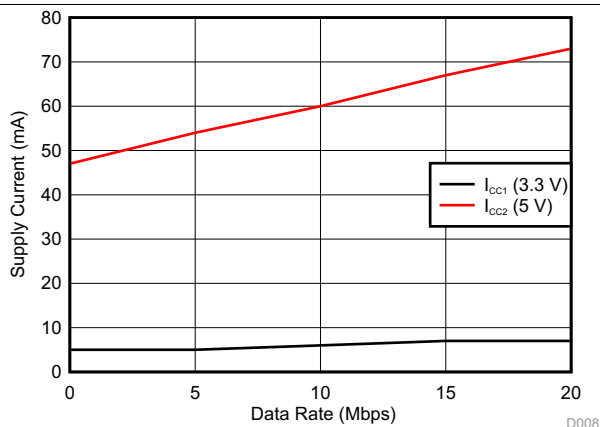

Figure 8. ISO3088 Supply Current vs Data Rate With Load

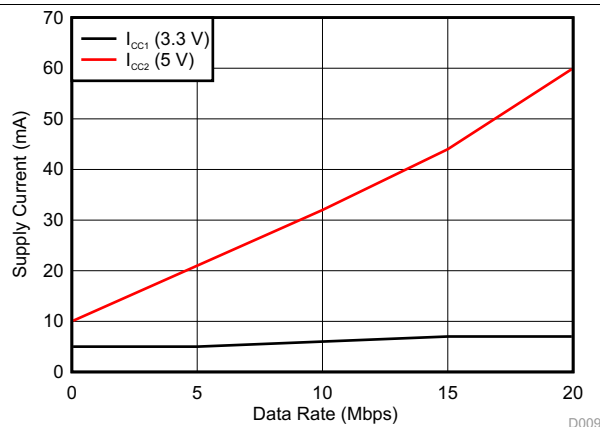

Figure 9. ISO3088 Supply Current vs Data Rate With No Load

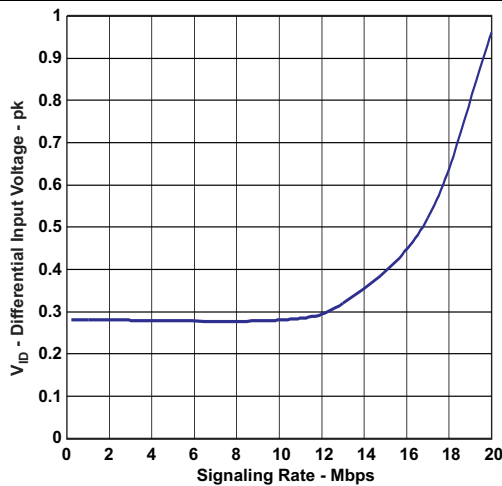

Figure 10. ISO3086 Recommended Minimum Differential Input Voltage vs Signaling Rate

7 Parameter Measurement Information

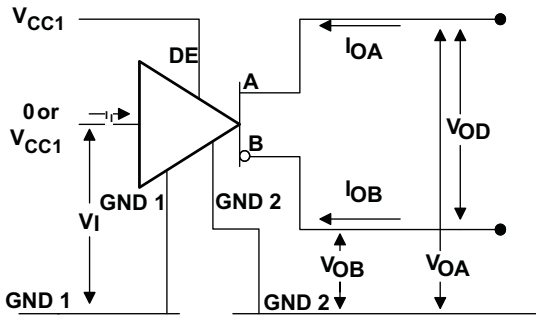

Figure 11. Driver V_{OD} Test and Current Definitions

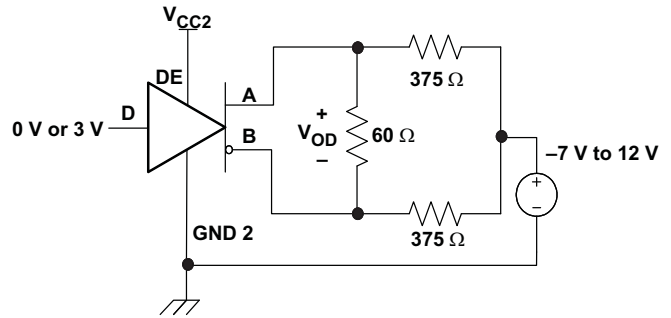
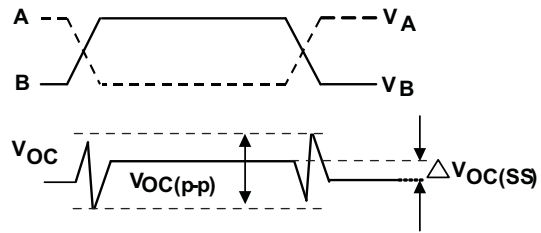
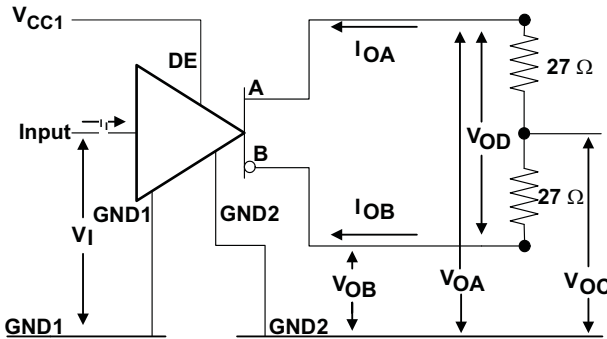

Figure 12. Driver V_{OD} With Common-Mode Loading Test Circuit

NOTE

Unless otherwise stated, test circuits are shown for half-duplex devices, ISO3082 and ISO3088. For full-duplex devices, the driver output pins are Y and Z.



Input Generator PRR= 100 kHz, 50 % duty cycle, $t_r < 6\text{ ns}$, $t_f < 6\text{ ns}$, $Z_O = 50 \Omega$

Figure 13. Test Circuit and Waveform Definitions For The Driver Common-Mode Output Voltage

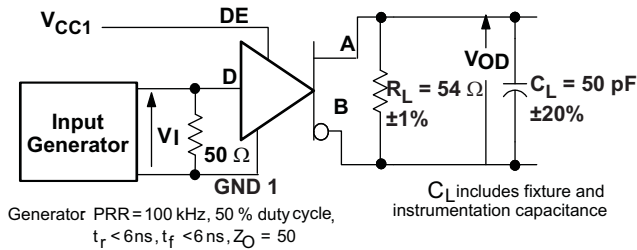

Generator PRR=100 kHz, 50 % duty cycle, $t_r < 6\text{ ns}$, $t_f < 6\text{ ns}$, $Z_O = 50$
 C_L includes fixture and instrumentation capacitance

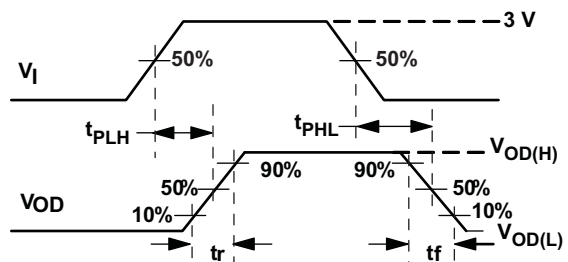

Figure 14. Driver Switching Test Circuit and Voltage Waveforms

Parameter Measurement Information (continued)

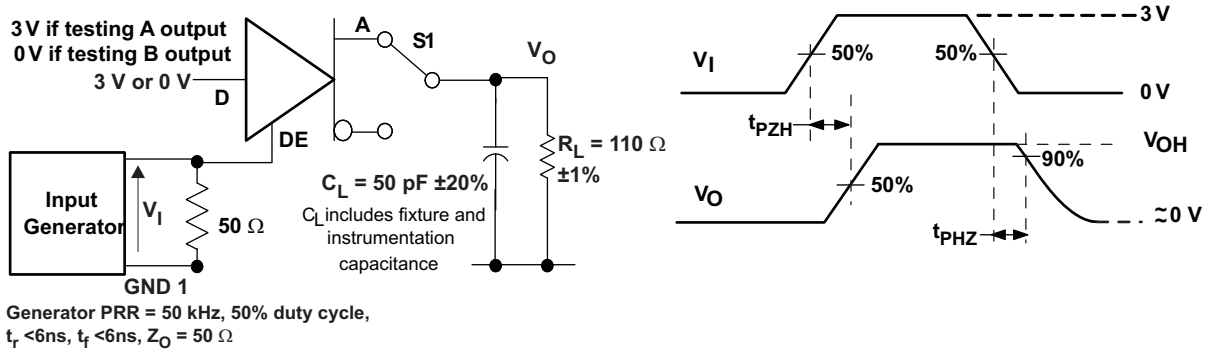

Figure 15. Driver High-Level Output Enable and Disable Time Test Circuit and Voltage Waveforms

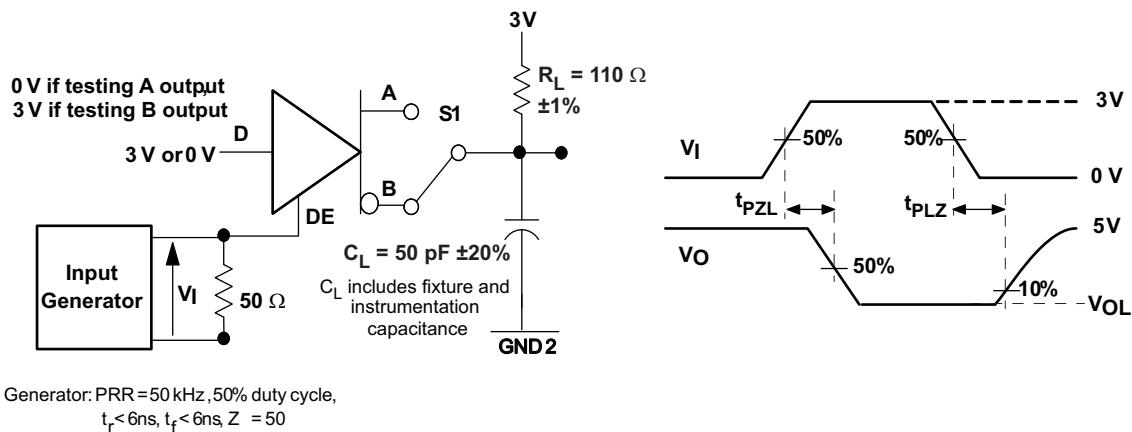

Figure 16. Driver Low-Level Output Enable and Disable Time Test Circuit and Voltage Waveform

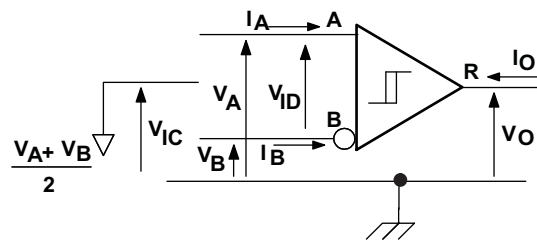

Figure 17. Receiver Voltage and Current Definitions

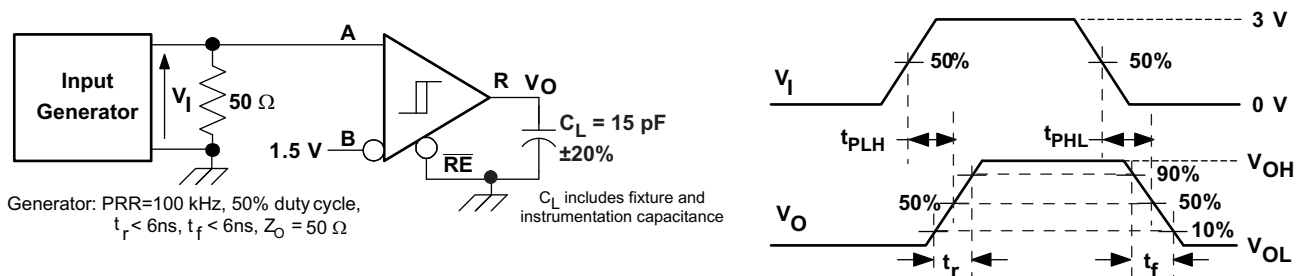

Figure 18. Receiver Switching Test Circuit and Waveforms

Parameter Measurement Information (continued)

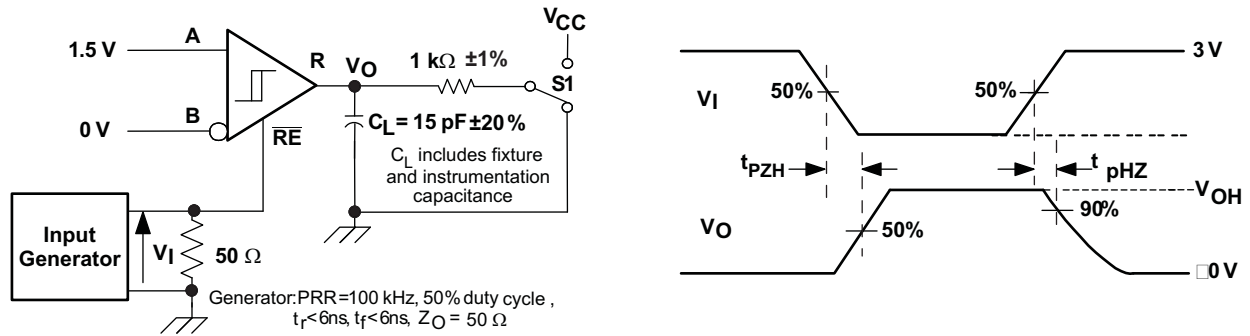

Figure 19. Receiver Enable Test Circuit and Waveforms, Data Output High

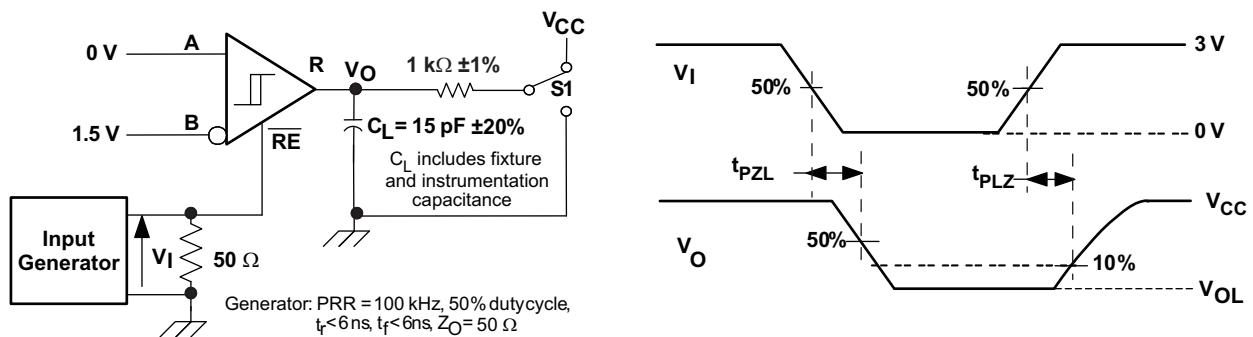
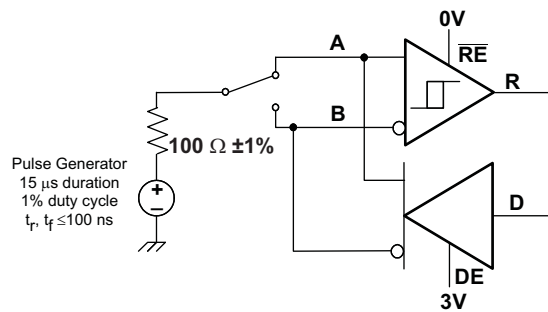

Figure 20. Receiver Enable Test Circuit and Waveforms, Data Output Low



Note: This test is conducted to test survivability only. Data stability at the R output is not specified.

Figure 21. Transient Overvoltage Test Circuit

Parameter Measurement Information (continued)

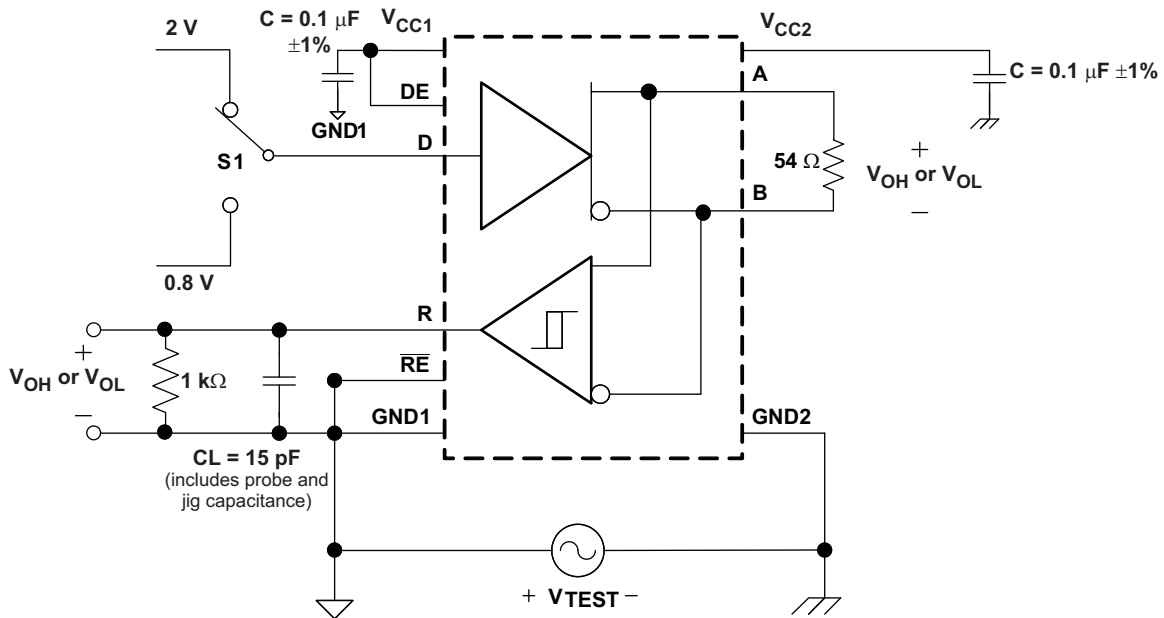

Figure 22. Half-Duplex Common-Mode Transient Immunity Test Circuit

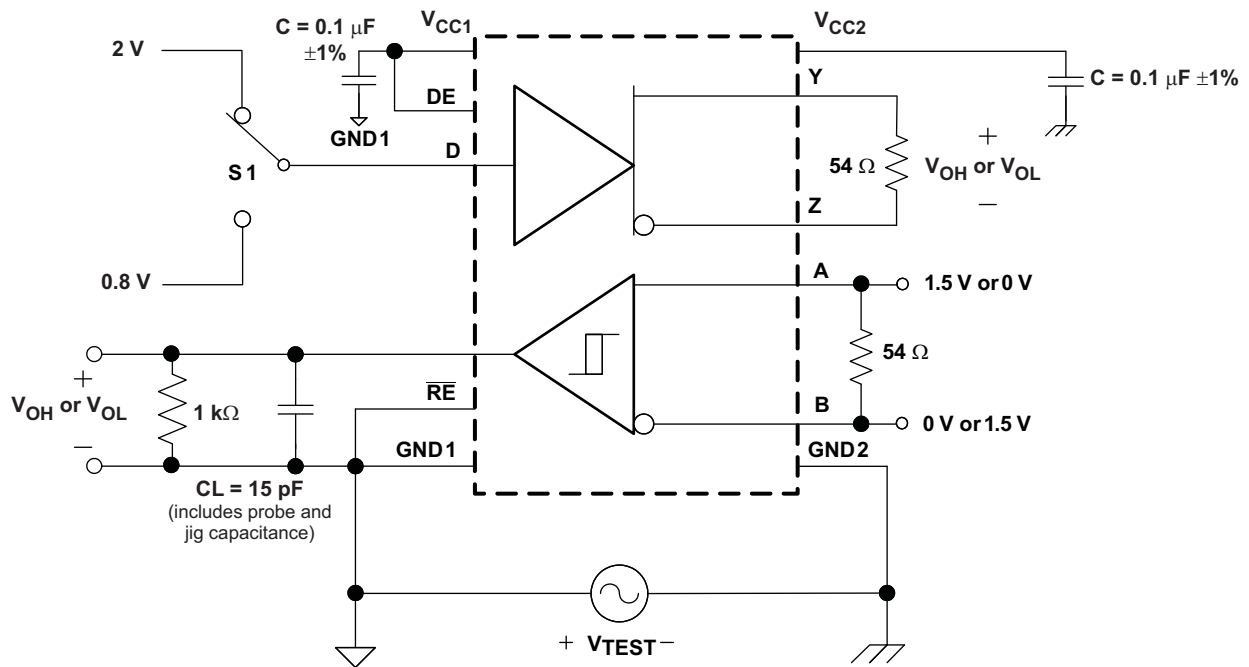

Figure 23. Full-Duplex Common-Mode Transient Immunity Test Circuit

8 Detailed Description

8.1 Overview

The ISO3080 and ISO3086 devices are isolated full-duplex differential line drivers and receivers while the ISO3082 and ISO3088 devices are isolated half-duplex differential line transceivers for TIA/EIA 485/422 applications. They are rated to provide galvanic isolation of up to 2500 V_{RMS} for 60 s as per the standard. They have active-high driver enables and active-low receiver enables to control the data flow. They are available in two speed grades suitable for data transmission up to 200 kbps and 20 Mbps.

When the driver enable pin, DE, is logic high, the differential outputs Y and Z follow the logic states at data input D. A logic high at D causes Y to turn high and Z to turn low. In this case the differential output voltage defined as $V_{OD} = V_{(Y)} - V_{(Z)}$ is positive. When D is low, the output states reverse, Z turns high, Y becomes low, and V_{OD} is negative. When DE is low, both outputs turn high-impedance. In this condition the logic state at D is irrelevant. The DE pin has an internal pulldown resistor to ground, thus when left open the driver is disabled (high-impedance) by default. The D pin has an internal pullup resistor to V_{CC}, thus, when left open while the driver is enabled, output Y turns high and Z turns low.

When the receiver enable pin, RE, is logic low, the receiver is enabled. When the differential input voltage defined as $V_{ID} = V_{(A)} - V_{(B)}$ is positive and higher than the positive input threshold, V_{IT+}, the receiver output, R, turns high. When V_{ID} is negative and less than the negative and lower than the negative input threshold, V_{IT-}, the receiver output, R, turns low. If V_{ID} is between V_{IT+} and V_{IT-} the output is indeterminate. When RE is logic high or left open, the receiver output is high-impedance and the magnitude and polarity of V_{ID} are irrelevant. Internal biasing of the receiver inputs causes the output to go failsafe-high when the transceiver is disconnected from the bus (open-circuit), the bus lines are shorted (short-circuit), or the bus is not actively driven (idle bus).

8.2 Functional Block Diagrams

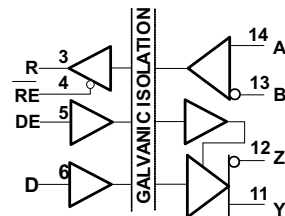

Figure 24. ISO3080, IOS3086 Functional Diagram

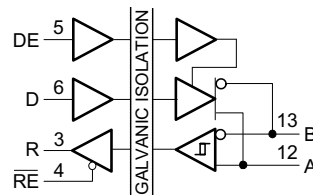

Figure 25. ISO3082, IOS3088 Functional Diagram

8.3 Feature Description

Table 1 provides an overview of the device features.

Table 1. Device Features

DEVICE	RATED ISOLATION ⁽¹⁾	TYPE	DATA RATE
ISO3080	4000 V _{PK} / 2500 V _{RMS}	Full-duplex	200 kbps
ISO3086	4000 V _{PK} / 2500 V _{RMS}	Full-duplex	20 Mbps
ISO3082	4000 V _{PK} / 2500 V _{RMS}	Half-duplex	200 kbps
ISO3088	4000 V _{PK} / 2500 V _{RMS}	Half-duplex	20 Mbps

(1) See [Safety-Related Certifications](#) table for detailed isolation ratings.

8.4 Device Functional Modes

Table 2 lists the driver functional modes and Table 3 lists the receiver functional modes.

Table 2. Driver Function Table⁽¹⁾

V _{CC1}	V _{CC2}	INPUT (D)	ENABLE INPUT (DE)	OUTPUTS ⁽²⁾	
				Y / A	Z / B
PU	PU	H	H	H	L
PU	PU	L	H	L	H
PU	PU	X	L	Hi-Z	Hi-Z
PU	PU	X	OPEN	Hi-Z	Hi-Z
PU	PU	OPEN	H	H	L
PD	PU	X	X	Hi-Z	Hi-Z
PU	PD	X	X	Hi-Z	Hi-Z
PD	PD	X	X	Hi-Z	Hi-Z

(1) PU = Powered Up; PD = Powered Down; H = Logic High; L = Logic Low; X = Irrelevant, Hi-Z = High Impedance (off)

(2) Driver output pins are Y and Z for full-duplex devices and A and B for half-duplex devices.

Table 3. Receiver Function Table⁽¹⁾

V _{CC1}	V _{CC2}	DIFFERENTIAL INPUT V _{ID} = (V _A - V _B)	ENABLE (RE)	OUTPUT (R)
PU	PU	-0.01 V ≤ V _{ID}	L	H
PU	PU	-0.2 V < V _{ID} < -0.01 V	L	?
PU	PU	V _{ID} ≤ -0.2 V	L	L
PU	PU	X	H	Hi-Z
PU	PU	X	OPEN	Hi-Z
PU	PU	Open circuit	L	H
PU	PU	Short circuit	L	H
PU	PU	Idle (terminated) bus	L	H
PD	PU	X	X	Hi-Z
PU	PD	X	L	H

(1) PU = Powered Up; PD = Powered Down; H = Logic High; L = Logic Low; X = Irrelevant, Hi-Z = High Impedance (off), ? = Indeterminate

8.4.1 Device I/O Schematics

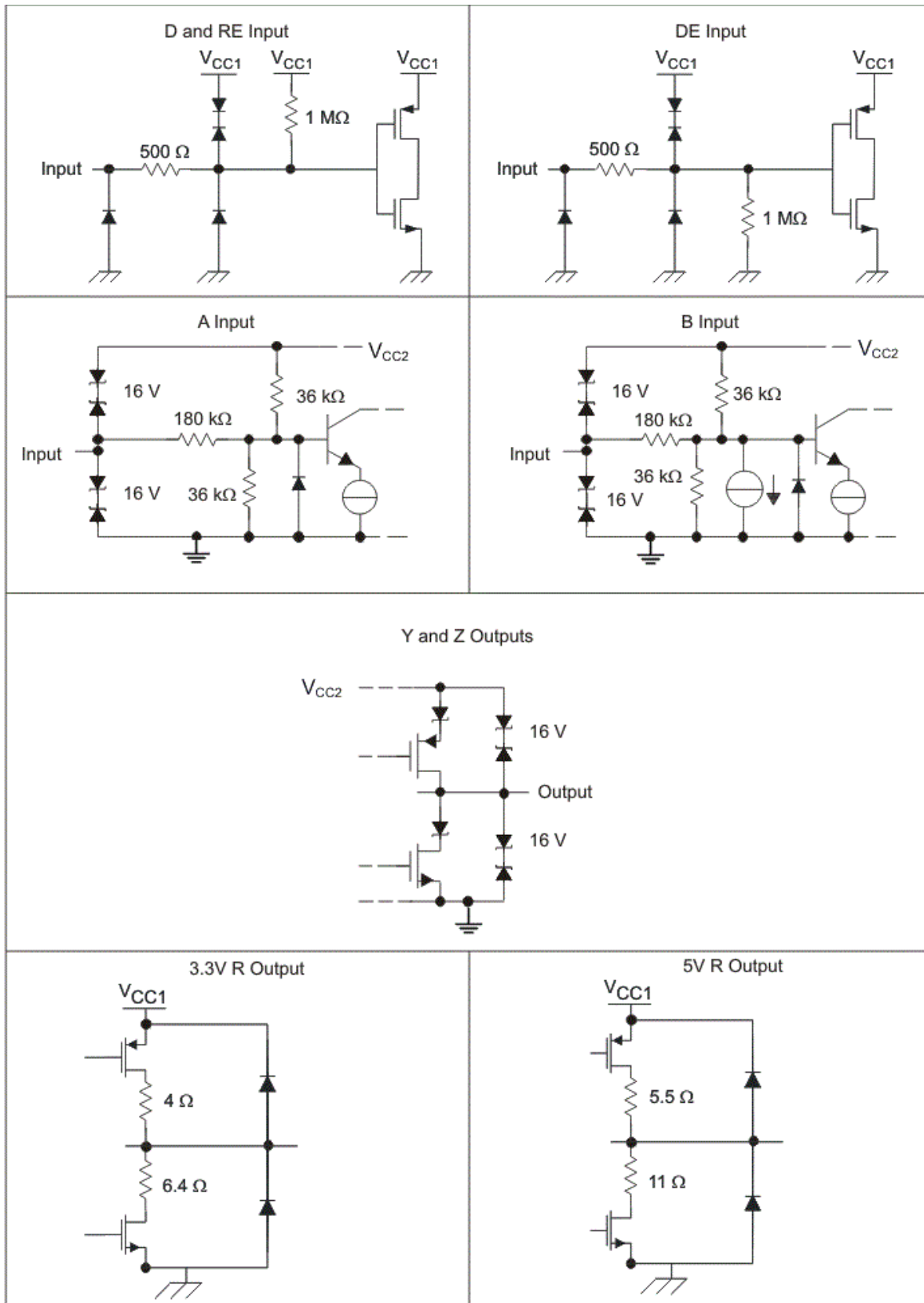

Figure 26. Device I/O Schematics

9 Application and Implementation

NOTE

Information in the following applications sections is not part of the TI component specification, and TI does not warrant its accuracy or completeness. TI's customers are responsible for determining suitability of components for their purposes. Customers should validate and test their design implementation to confirm system functionality.

9.1 Application Information

The ISO308x family consists of RS-485 transceivers commonly used for asynchronous data transmissions. Full-duplex implementation requires two signal pairs (four wires), and allows each node to transmit data on one pair while simultaneously receiving data on the other pair. For half-duplex transmission, only one pair is shared for both transmission and reception of data. To eliminate line reflections, each cable end is terminated with a termination resistor, $R(T)$, whose value matches the characteristic impedance, Z_0 , of the cable. This method, known as parallel termination, allows for higher data rates over longer cable length.

9.2 Typical Application

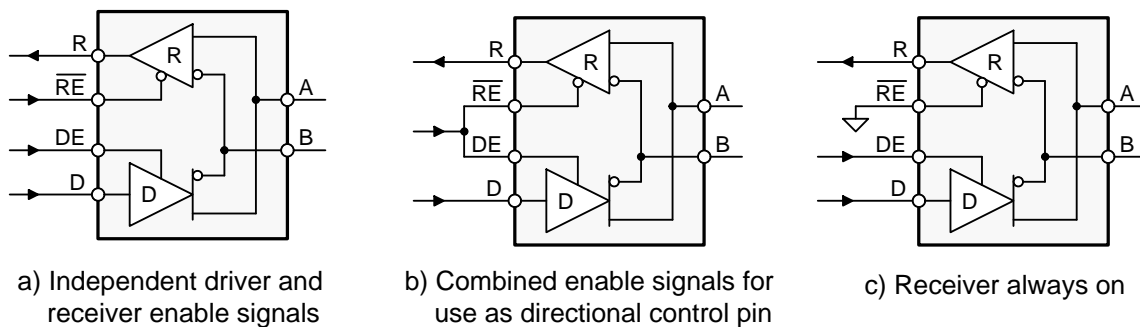

Copyright © 2016, Texas Instruments Incorporated

Figure 27. Half-Duplex Transceiver Configurations

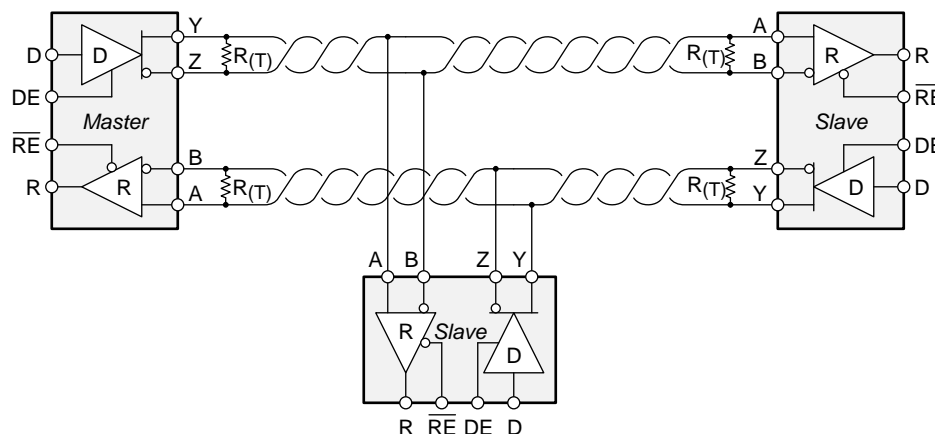

Figure 28. Typical RS-485 Network With Full-Duplex Transceivers

Typical Application (continued)

9.2.1 Design Requirements

RS-485 is a robust electrical standard suitable for long-distance networking that can be used in a wide range of applications with varying requirements, such as distance, data rate, and number of nodes. [Table 4](#) lists the design parameters.

Table 4. Design Parameters

PARAMETER	VALUE
Pullup and pulldown resistors	1 kΩ to 10 kΩ
Decoupling capacitors	100 nF

9.2.2 Detailed Design Procedure

The data rate and cable length have an inverse relationship which means the higher the data rate, the shorter the cable length; and conversely, the lower the data rate, the longer the cable length. When connecting a node to the bus, the distance between the transceiver inputs and the cable trunk, known as the stub, should be as short as possible. Stubs present a nonterminated piece of bus line which can introduce reflections as the length of the stub increases. As a general guideline, the electrical length, or round-trip delay, of a stub should be less than one-tenth of the rise time of the driver. The RS-485 standard specifies that a compliant driver must be able to driver 32 unit loads (ULs), where 1 UL represents a load impedance of approximately 12 kΩ. Because the ISO308x family consists of 1/8 UL transceivers, connecting up to 256 receivers to the bus is possible.

9.2.3 Application Curve

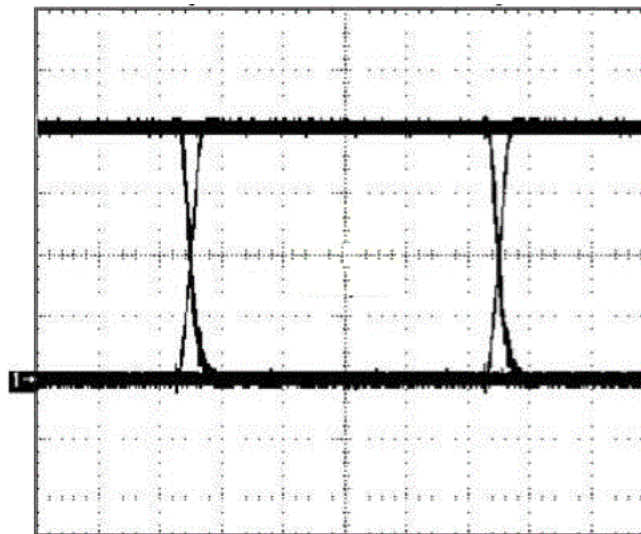

Figure 29. ISO308x Output

10 Power Supply Recommendations

To help ensure reliable operation at all data rates and supply voltages, a 0.1- μ F bypass capacitor is recommended at the input and output supply pins (V_{CC1} and V_{CC2}). The capacitors should be placed as close to the supply pins as possible. If only a single primary-side power supply is available in an application, isolated power can be generated for the secondary-side with the help of a transformer driver such as Texas Instruments' [SN6501](#). For such applications, detailed power supply design and transformer selection recommendations are available in [SN6501 Transformer Driver for Isolated Power Supplies](#).

11 Layout

11.1 Layout Guidelines

ON-chip IEC-ESD protection is good for laboratory and portable equipment but never sufficient for EFT and surge transients occurring in industrial environments. Therefore, robust and reliable bus node design requires the use of external transient protection devices. Because ESD and EFT transients have a wide frequency bandwidth from approximately 3-MHz to 3-GHz, high-frequency layout techniques must be applied during PCB design. A minimum of four layers is required to accomplish a low EMI PCB design (see [Figure 30](#)).

- Layer stacking should be in the following order (top-to-bottom): high-speed signal layer, ground plane, power plane, and low-frequency signal layer.
- Routing the high-speed traces on the top layer avoids the use of vias (and the introduction of their inductances) and allows for clean interconnects between the isolator and the transmitter and receiver circuits of the data link.
- Placing a solid ground plane next to the high-speed signal layer establishes controlled impedance for transmission line interconnects and provides an excellent low-inductance path for the return current flow.
- Placing the power plane next to the ground plane creates additional high-frequency bypass capacitance of approximately 100 pF/in².
- Routing the slower speed control signals on the bottom layer allows for greater flexibility as these signal links usually have margin to tolerate discontinuities such as vias.
- Place the protection circuitry close to the bus connector to prevent noise transients from penetrating your board.
- Use V_{CC} and ground planes to provide low-inductance. High-frequency currents might follow the path of least inductance and not necessarily the path of least resistance.
- Design the protection components into the direction of the signal path. Do not force the transient currents to divert from the signal path to reach the protection device.
- Apply 0.1- μ F bypass capacitors as close as possible to the V_{CC} -pins of transceiver, UART, and controller ICs on the board.
- Use at least two vias for V_{CC} and ground connections of bypass capacitors and protection devices to minimize effective via-inductance.
- Use 1-k Ω to 10-k Ω pullup and pulldown resistors for enable lines to limit noise currents in these lines during transient events.
- Insert pulse-proof resistors into the A and B bus lines if the TVS clamping voltage is higher than the specified maximum voltage of the transceiver bus pins. These resistors limit the residual clamping current into the transceiver and prevent it from latching up.
- While pure TVS protection is sufficient for surge transients up to 1 kV, higher transients require metal-oxide varistors (MOVs) which reduce the transients to a few hundred volts of clamping voltage, and transient blocking units (TBUs) that limit transient current to less than 1 mA.

Layout Guidelines (continued)

If an additional supply voltage plane or signal layer is needed, add a second power or ground plane system to the stack to keep it symmetrical. This makes the stack mechanically stable and prevents it from warping. Also the power and ground plane of each power system can be placed closer together, thus increasing the high-frequency bypass capacitance significantly.

For detailed layout recommendations, refer to the [Digital Isolator Design Guide](#).

11.2 Layout Example

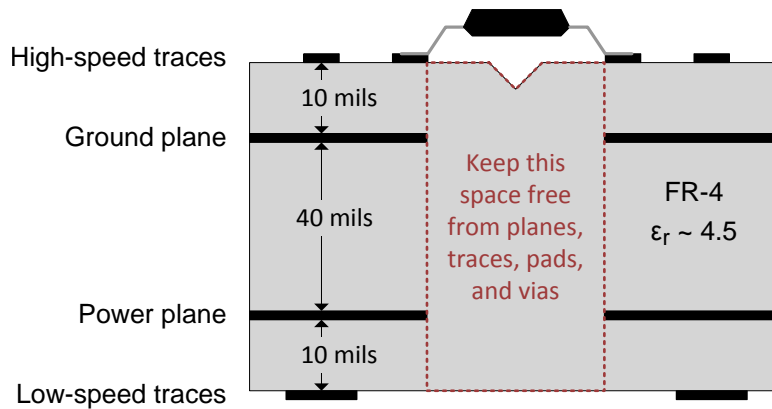

Figure 30. Recommended Layer Stack

12 Device and Documentation Support

12.1 Documentation Support

12.1.1 Related Documentation

For related documentation see the following:

- [Communication Module Reference Design for Functional Isolated RS-485, CAN, and I2C Data Transmission](#)
- [Digital Isolator Design Guide](#)
- [Dual Isolated Half-Duplex RS-485 Repeater](#)
- [Isolation Glossary](#)
- [Programmable Logic Controller \(PLC\) I/O Module Front- End Controller with Tiva C Series ARM® Cortex®-M4 MCU](#)
- [Small Form Factor, Digital Isolator-Based Half-Duplex RS- 485 Interface Module Reference Design](#)
- [SN6501 Transformer Driver for Isolated Power Supplies](#)

12.2 Related Links

The table below lists quick access links. Categories include technical documents, support and community resources, tools and software, and quick access to sample or buy.

Table 5. Related Links

PARTS	PRODUCT FOLDER	ORDER NOW	TECHNICAL DOCUMENTS	TOOLS & SOFTWARE	SUPPORT & COMMUNITY
ISO3080	Click here	Click here	Click here	Click here	Click here
ISO3082	Click here	Click here	Click here	Click here	Click here
ISO3086	Click here	Click here	Click here	Click here	Click here
ISO3088	Click here	Click here	Click here	Click here	Click here

12.3 Receiving Notification of Documentation Updates

To receive notification of documentation updates, navigate to the device product folder on ti.com. In the upper right corner, click on *Alert me* to register and receive a weekly digest of any product information that has changed. For change details, review the revision history included in any revised document.

12.4 Community Resources

The following links connect to TI community resources. Linked contents are provided "AS IS" by the respective contributors. They do not constitute TI specifications and do not necessarily reflect TI's views; see TI's [Terms of Use](#).

TI E2E™ Online Community *TI's Engineer-to-Engineer (E2E) Community*. Created to foster collaboration among engineers. At e2e.ti.com, you can ask questions, share knowledge, explore ideas and help solve problems with fellow engineers.

Design Support *TI's Design Support* Quickly find helpful E2E forums along with design support tools and contact information for technical support.

12.5 Trademarks

E2E is a trademark of Texas Instruments.
ARM, Cortex are registered trademarks of ARM Ltd..
All other trademarks are the property of their respective owners.

12.6 Electrostatic Discharge Caution



These devices have limited built-in ESD protection. The leads should be shorted together or the device placed in conductive foam during storage or handling to prevent electrostatic damage to the MOS gates.

12.7 Glossary

[SLYZ022](#) — *TI Glossary*.

This glossary lists and explains terms, acronyms, and definitions.

13 Mechanical, Packaging, and Orderable Information

The following pages include mechanical, packaging, and orderable information. This information is the most current data available for the designated devices. This data is subject to change without notice and revision of this document. For browser-based versions of this data sheet, refer to the left-hand navigation.



PACKAGE OUTLINE

DW0016B
SOIC - 2.65 mm max height

SOIC

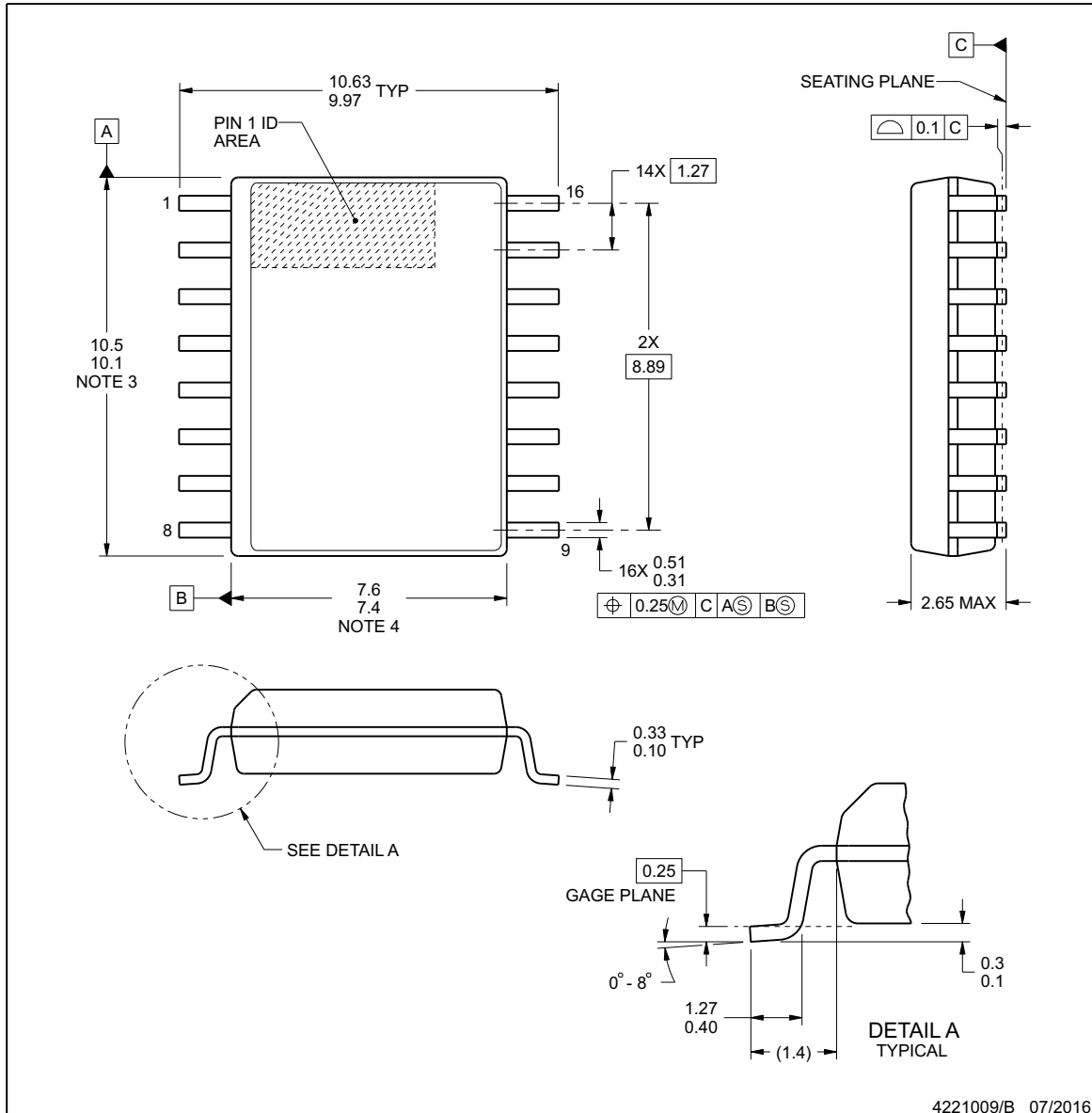
NOTES:

1. All linear dimensions are in millimeters. Dimensions in parenthesis are for reference only. Dimensioning and tolerancing per ASME Y14.5M.
2. This drawing is subject to change without notice.
3. This dimension does not include mold flash, protrusions, or gate burrs. Mold flash, protrusions, or gate burrs shall not exceed 0.15 mm, per side.
4. This dimension does not include interlead flash. Interlead flash shall not exceed 0.25 mm, per side.
5. Reference JEDEC registration MS-013.

EXAMPLE BOARD LAYOUT

DW0016B

SOIC - 2.65 mm max height

SOIC

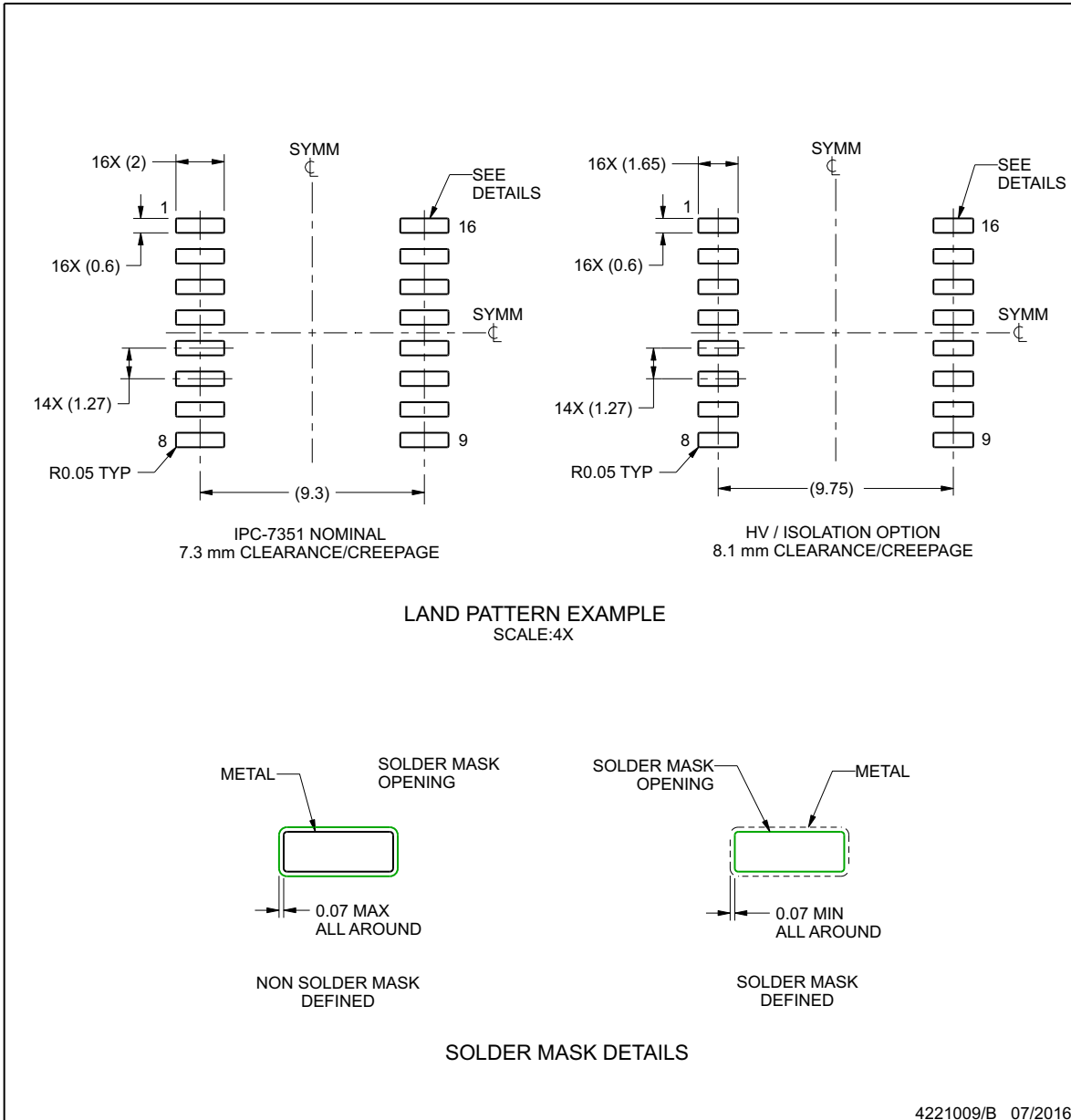

NOTES: (continued)

- 6. Publication IPC-7351 may have alternate designs.
- 7. Solder mask tolerances between and around signal pads can vary based on board fabrication site.

EXAMPLE STENCIL DESIGN

DW0016B
SOIC - 2.65 mm max height

SOIC

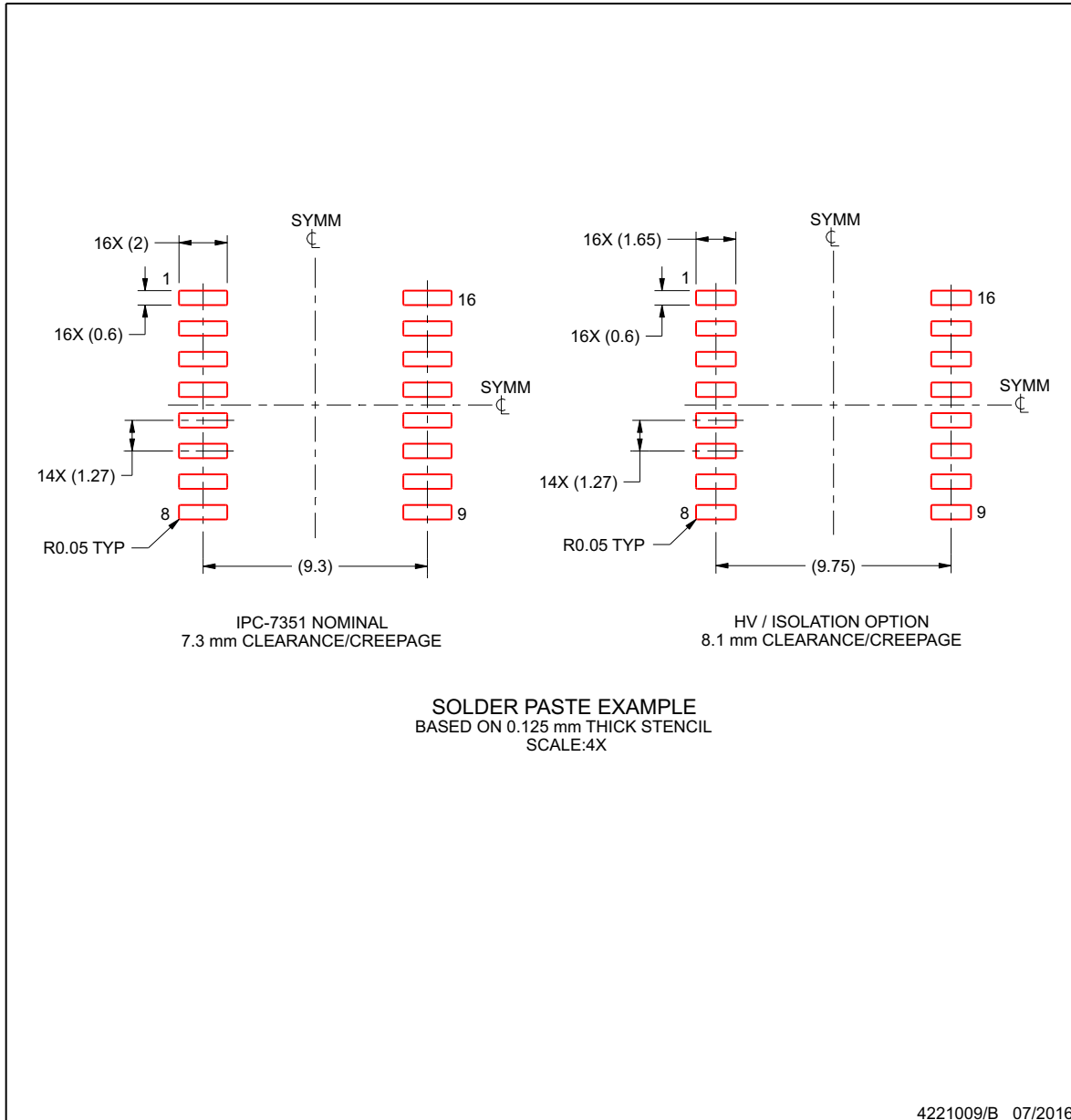

NOTES: (continued)

8. Laser cutting apertures with trapezoidal walls and rounded corners may offer better paste release. IPC-7525 may have alternate design recommendations.
9. Board assembly site may have different recommendations for stencil design.

PACKAGING INFORMATION

Orderable Device	Status (1)	Package Type	Package Drawing	Pins	Package Qty	Eco Plan (2)	Lead/Ball Finish (6)	MSL Peak Temp (3)	Op Temp (°C)	Device Marking (4/5)	Samples
ISO3080DW	ACTIVE	SOIC	DW	16	40	Green (RoHS & no Sb/Br)	CU NIPDAU	Level-2-260C-1 YEAR	-40 to 85	ISO3080	Samples
ISO3080DWG4	ACTIVE	SOIC	DW	16	40	Green (RoHS & no Sb/Br)	CU NIPDAU	Level-2-260C-1 YEAR	-40 to 85	ISO3080	Samples
ISO3080DWR	ACTIVE	SOIC	DW	16	2000	Green (RoHS & no Sb/Br)	CU NIPDAU	Level-2-260C-1 YEAR	-40 to 85	ISO3080	Samples
ISO3082DW	ACTIVE	SOIC	DW	16	40	Green (RoHS & no Sb/Br)	CU NIPDAU	Level-2-260C-1 YEAR	-40 to 85	ISO3082	Samples
ISO3082DWG4	ACTIVE	SOIC	DW	16	40	Green (RoHS & no Sb/Br)	CU NIPDAU	Level-2-260C-1 YEAR	-40 to 85	ISO3082	Samples
ISO3082DWR	ACTIVE	SOIC	DW	16	2000	Green (RoHS & no Sb/Br)	CU NIPDAU	Level-2-260C-1 YEAR	-40 to 85	ISO3082	Samples
ISO3082DWRG4	ACTIVE	SOIC	DW	16	2000	Green (RoHS & no Sb/Br)	CU NIPDAU	Level-2-260C-1 YEAR	-40 to 85	ISO3082	Samples
ISO3086DW	ACTIVE	SOIC	DW	16	40	Green (RoHS & no Sb/Br)	CU NIPDAU	Level-2-260C-1 YEAR	-40 to 85	ISO3086	Samples
ISO3086DWG4	ACTIVE	SOIC	DW	16	40	Green (RoHS & no Sb/Br)	CU NIPDAU	Level-2-260C-1 YEAR	-40 to 85	ISO3086	Samples
ISO3086DWR	ACTIVE	SOIC	DW	16	2000	Green (RoHS & no Sb/Br)	CU NIPDAU	Level-2-260C-1 YEAR	-40 to 85	ISO3086	Samples
ISO3088DW	ACTIVE	SOIC	DW	16	40	Green (RoHS & no Sb/Br)	CU NIPDAU	Level-2-260C-1 YEAR	-40 to 85	ISO3088	Samples
ISO3088DWG4	ACTIVE	SOIC	DW	16	40	Green (RoHS & no Sb/Br)	CU NIPDAU	Level-2-260C-1 YEAR	-40 to 85	ISO3088	Samples
ISO3088DWR	ACTIVE	SOIC	DW	16	2000	Green (RoHS & no Sb/Br)	CU NIPDAU	Level-2-260C-1 YEAR	-40 to 85	ISO3088	Samples
ISO3088DWRG4	ACTIVE	SOIC	DW	16	2000	Green (RoHS & no Sb/Br)	CU NIPDAU	Level-2-260C-1 YEAR	-40 to 85	ISO3088	Samples

(1) The marketing status values are defined as follows:

ACTIVE: Product device recommended for new designs.

LIFEBUY: TI has announced that the device will be discontinued, and a lifetime-buy period is in effect.

NRND: Not recommended for new designs. Device is in production to support existing customers, but TI does not recommend using this part in a new design.

PREVIEW: Device has been announced but is not in production. Samples may or may not be available.

OBSELETE: TI has discontinued the production of the device.

⁽²⁾ **RoHS:** TI defines "RoHS" to mean semiconductor products that are compliant with the current EU RoHS requirements for all 10 RoHS substances, including the requirement that RoHS substance do not exceed 0.1% by weight in homogeneous materials. Where designed to be soldered at high temperatures, "RoHS" products are suitable for use in specified lead-free processes. TI may reference these types of products as "Pb-Free".

RoHS Exempt: TI defines "RoHS Exempt" to mean products that contain lead but are compliant with EU RoHS pursuant to a specific EU RoHS exemption.

Green: TI defines "Green" to mean the content of Chlorine (Cl) and Bromine (Br) based flame retardants meet JS709B low halogen requirements of ≤ 1000 ppm threshold. Antimony trioxide based flame retardants must also meet the ≤ 1000 ppm threshold requirement.

⁽³⁾ MSL, Peak Temp. - The Moisture Sensitivity Level rating according to the JEDEC industry standard classifications, and peak solder temperature.

⁽⁴⁾ There may be additional marking, which relates to the logo, the lot trace code information, or the environmental category on the device.

⁽⁵⁾ Multiple Device Markings will be inside parentheses. Only one Device Marking contained in parentheses and separated by a "-" will appear on a device. If a line is indented then it is a continuation of the previous line and the two combined represent the entire Device Marking for that device.

⁽⁶⁾ Lead/Ball Finish - Orderable Devices may have multiple material finish options. Finish options are separated by a vertical ruled line. Lead/Ball Finish values may wrap to two lines if the finish value exceeds the maximum column width.

Important Information and Disclaimer: The information provided on this page represents TI's knowledge and belief as of the date that it is provided. TI bases its knowledge and belief on information provided by third parties, and makes no representation or warranty as to the accuracy of such information. Efforts are underway to better integrate information from third parties. TI has taken and continues to take reasonable steps to provide representative and accurate information but may not have conducted destructive testing or chemical analysis on incoming materials and chemicals. TI and TI suppliers consider certain information to be proprietary, and thus CAS numbers and other limited information may not be available for release.

In no event shall TI's liability arising out of such information exceed the total purchase price of the TI part(s) at issue in this document sold by TI to Customer on an annual basis.

TAPE AND REEL INFORMATION



QUADRANT ASSIGNMENTS FOR PIN 1 ORIENTATION IN TAPE



*All dimensions are nominal

Device	Package Type	Package Drawing	Pins	SPQ	Reel Diameter (mm)	Reel Width W1 (mm)	A0 (mm)	B0 (mm)	K0 (mm)	P1 (mm)	W (mm)	Pin1 Quadrant
ISO3080DWR	SOIC	DW	16	2000	330.0	16.4	10.75	10.7	2.7	12.0	16.0	Q1
ISO3082DWR	SOIC	DW	16	2000	330.0	16.4	10.75	10.7	2.7	12.0	16.0	Q1
ISO3086DWR	SOIC	DW	16	2000	330.0	16.4	10.75	10.7	2.7	12.0	16.0	Q1
ISO3088DWR	SOIC	DW	16	2000	330.0	16.4	10.75	10.7	2.7	12.0	16.0	Q1

TAPE AND REEL BOX DIMENSIONS



*All dimensions are nominal

Device	Package Type	Package Drawing	Pins	SPQ	Length (mm)	Width (mm)	Height (mm)
ISO3080DWR	SOIC	DW	16	2000	367.0	367.0	38.0
ISO3082DWR	SOIC	DW	16	2000	367.0	367.0	38.0
ISO3086DWR	SOIC	DW	16	2000	367.0	367.0	38.0
ISO3088DWR	SOIC	DW	16	2000	367.0	367.0	38.0

IMPORTANT NOTICE

Texas Instruments Incorporated (TI) reserves the right to make corrections, enhancements, improvements and other changes to its semiconductor products and services per JESD46, latest issue, and to discontinue any product or service per JESD48, latest issue. Buyers should obtain the latest relevant information before placing orders and should verify that such information is current and complete.

TI's published terms of sale for semiconductor products (<http://www.ti.com/sc/docs/stdterms.htm>) apply to the sale of packaged integrated circuit products that TI has qualified and released to market. Additional terms may apply to the use or sale of other types of TI products and services.

Reproduction of significant portions of TI information in TI data sheets is permissible only if reproduction is without alteration and is accompanied by all associated warranties, conditions, limitations, and notices. TI is not responsible or liable for such reproduced documentation. Information of third parties may be subject to additional restrictions. Resale of TI products or services with statements different from or beyond the parameters stated by TI for that product or service voids all express and any implied warranties for the associated TI product or service and is an unfair and deceptive business practice. TI is not responsible or liable for any such statements.

Buyers and others who are developing systems that incorporate TI products (collectively, "Designers") understand and agree that Designers remain responsible for using their independent analysis, evaluation and judgment in designing their applications and that Designers have full and exclusive responsibility to assure the safety of Designers' applications and compliance of their applications (and of all TI products used in or for Designers' applications) with all applicable regulations, laws and other applicable requirements. Designer represents that, with respect to their applications, Designer has all the necessary expertise to create and implement safeguards that (1) anticipate dangerous consequences of failures, (2) monitor failures and their consequences, and (3) lessen the likelihood of failures that might cause harm and take appropriate actions. Designer agrees that prior to using or distributing any applications that include TI products, Designer will thoroughly test such applications and the functionality of such TI products as used in such applications.

TI's provision of technical, application or other design advice, quality characterization, reliability data or other services or information, including, but not limited to, reference designs and materials relating to evaluation modules, (collectively, "TI Resources") are intended to assist designers who are developing applications that incorporate TI products; by downloading, accessing or using TI Resources in any way, Designer (individually or, if Designer is acting on behalf of a company, Designer's company) agrees to use any particular TI Resource solely for this purpose and subject to the terms of this Notice.

TI's provision of TI Resources does not expand or otherwise alter TI's applicable published warranties or warranty disclaimers for TI products, and no additional obligations or liabilities arise from TI providing such TI Resources. TI reserves the right to make corrections, enhancements, improvements and other changes to its TI Resources. TI has not conducted any testing other than that specifically described in the published documentation for a particular TI Resource.

Designer is authorized to use, copy and modify any individual TI Resource only in connection with the development of applications that include the TI product(s) identified in such TI Resource. NO OTHER LICENSE, EXPRESS OR IMPLIED, BY ESTOPPEL OR OTHERWISE TO ANY OTHER TI INTELLECTUAL PROPERTY RIGHT, AND NO LICENSE TO ANY TECHNOLOGY OR INTELLECTUAL PROPERTY RIGHT OF TI OR ANY THIRD PARTY IS GRANTED HEREIN, including but not limited to any patent right, copyright, mask work right, or other intellectual property right relating to any combination, machine, or process in which TI products or services are used. Information regarding or referencing third-party products or services does not constitute a license to use such products or services, or a warranty or endorsement thereof. Use of TI Resources may require a license from a third party under the patents or other intellectual property of the third party, or a license from TI under the patents or other intellectual property of TI.

TI RESOURCES ARE PROVIDED "AS IS" AND WITH ALL FAULTS. TI DISCLAIMS ALL OTHER WARRANTIES OR REPRESENTATIONS, EXPRESS OR IMPLIED, REGARDING RESOURCES OR USE THEREOF, INCLUDING BUT NOT LIMITED TO ACCURACY OR COMPLETENESS, TITLE, ANY EPIDEMIC FAILURE WARRANTY AND ANY IMPLIED WARRANTIES OF MERCHANTABILITY, FITNESS FOR A PARTICULAR PURPOSE, AND NON-INFRINGEMENT OF ANY THIRD PARTY INTELLECTUAL PROPERTY RIGHTS. TI SHALL NOT BE LIABLE FOR AND SHALL NOT DEFEND OR INDEMNIFY DESIGNER AGAINST ANY CLAIM, INCLUDING BUT NOT LIMITED TO ANY INFRINGEMENT CLAIM THAT RELATES TO OR IS BASED ON ANY COMBINATION OF PRODUCTS EVEN IF DESCRIBED IN TI RESOURCES OR OTHERWISE. IN NO EVENT SHALL TI BE LIABLE FOR ANY ACTUAL, DIRECT, SPECIAL, COLLATERAL, INDIRECT, PUNITIVE, INCIDENTAL, CONSEQUENTIAL OR EXEMPLARY DAMAGES IN CONNECTION WITH OR ARISING OUT OF TI RESOURCES OR USE THEREOF, AND REGARDLESS OF WHETHER TI HAS BEEN ADVISED OF THE POSSIBILITY OF SUCH DAMAGES.

Unless TI has explicitly designated an individual product as meeting the requirements of a particular industry standard (e.g., ISO/TS 16949 and ISO 26262), TI is not responsible for any failure to meet such industry standard requirements.

Where TI specifically promotes products as facilitating functional safety or as compliant with industry functional safety standards, such products are intended to help enable customers to design and create their own applications that meet applicable functional safety standards and requirements. Using products in an application does not by itself establish any safety features in the application. Designers must ensure compliance with safety-related requirements and standards applicable to their applications. Designer may not use any TI products in life-critical medical equipment unless authorized officers of the parties have executed a special contract specifically governing such use. Life-critical medical equipment is medical equipment where failure of such equipment would cause serious bodily injury or death (e.g., life support, pacemakers, defibrillators, heart pumps, neurostimulators, and implantables). Such equipment includes, without limitation, all medical devices identified by the U.S. Food and Drug Administration as Class III devices and equivalent classifications outside the U.S.

TI may expressly designate certain products as completing a particular qualification (e.g., Q100, Military Grade, or Enhanced Product). Designers agree that it has the necessary expertise to select the product with the appropriate qualification designation for their applications and that proper product selection is at Designers' own risk. Designers are solely responsible for compliance with all legal and regulatory requirements in connection with such selection.

Designer will fully indemnify TI and its representatives against any damages, costs, losses, and/or liabilities arising out of Designer's non-compliance with the terms and provisions of this Notice.