



JST08 Series 8A TRIACs

Rev.8.0

DESCRIPTION:

With high ability to withstand the shock loading of large current, JST08 series triacs provide high dv/dt rate with strong resistance to electromagnetic interference. With high commutation performances, 3 quadrants products especially recommended for use on inductive load. From all three terminals to external heatsink, JST08A provides a rated insulation voltage of 2500 V_{RMS}, and JST08F provides a rated insulation voltage of 2000 V_{RMS}, complying with UL standards (File ref: E252906).

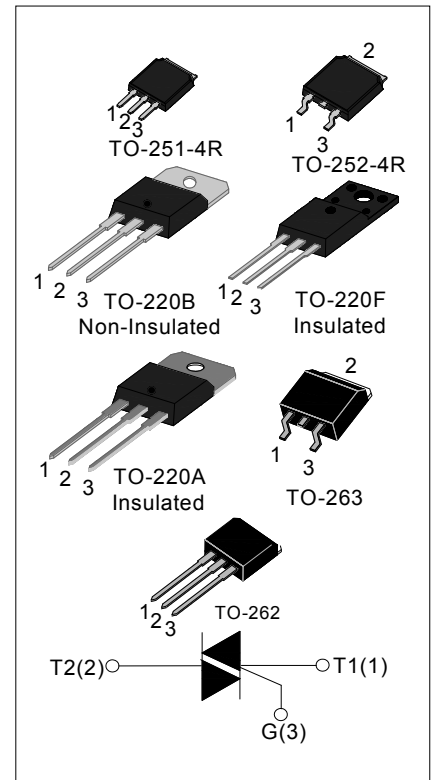

MAIN FEATURES

Symbol	Value	Unit
$I_{T(RMS)}$	8	A
V_{DRM}/V_{RRM}	600 and 800 and 1200	V

ABSOLUTE MAXIMUM RATINGS

Parameter	Symbol	Value	Unit
Storage junction temperature range	T_{stg}	-40 - 150	°C
Operating junction temperature range	T_j	-40 - 125	°C
Repetitive peak off-state voltage ($T_j=25^\circ\text{C}$)	V_{DRM}	600/800/1200	V
Repetitive peak reverse voltage ($T_j=25^\circ\text{C}$)	V_{RRM}	600/800/1200	V
Non repetitive surge peak Off-state voltage	V_{DSM}	$V_{DRM} + 100$	V
Non repetitive peak reverse voltage	V_{RSM}	$V_{RRM} + 100$	V
RMS on-state current	TO-252-4R/ TO-251-4R/ TO-220B(Non-Ins) ($T_C=107^\circ\text{C}$)	8	A
	TO-220A(Ins) ($T_C=100^\circ\text{C}$)		
	TO-220F(Ins) ($T_C=95^\circ\text{C}$)		
	TO-262/TO-263 ($T_C=90^\circ\text{C}$)		

Non repetitive surge peak on-state current (full cycle, F=50Hz)	I_{TSM}	80	A
I^2t value for fusing (tp=10ms)	I^2t	32	A^2s
Critical rate of rise of on-state current ($I_G=2 \times I_{GT}$)	dI/dt	50	$A/\mu s$
Peak gate current	I_{GM}	4	A
Average gate power dissipation	$P_{G(AV)}$	1	W
Peak gate power	P_{GM}	5	W

ELECTRICAL CHARACTERISTICS ($T_j=25^\circ C$ unless otherwise specified)

3 Quadrants

Symbol	Test Condition	Quadrant		Value				Unit
				TW	SW	CW	BW	
I_{GT}	$V_D=12V R_L=33\Omega$	I - II -III	MAX	5	10	35	50	mA
V_{GT}		I - II -III	MAX	1.5				V
V_{GD}	$V_D=V_{DRM} T_j=125^\circ C$ $R_L=3.3K\Omega$	I - II -III	MIN	0.2				V
I_L	$I_G=1.2I_{GT}$	I -III	MAX	20	25	50	70	mA
		II		25	35	70	90	
I_H	$I_{TM}=100mA$		MAX	15	20	40	60	mA
dV/dt	$V_D=2/3V_{DRM}$ Gate Open $T_j=125^\circ C$		MIN	50	200	500	1000	$V/\mu s$

4 Quadrants

Symbol	Test Condition	Quadrant		Value		Unit
				C	B	
I_{GT}	$V_D=12V R_L=33\Omega$	I - II -III	MAX	25	50	mA
		IV		50	70	
V_{GT}		ALL	MAX	1.5		V
V_{GD}	$V_D=V_{DRM} T_j=125^\circ C$ $R_L=3.3K\Omega$	ALL	MIN	0.2		V
I_L	$I_G=1.2I_{GT}$	I -III-IV	MAX	50	70	mA
		II		70	90	
I_H	$I_{TM}=200mA$		MAX	40	60	mA
dV/dt	$V_D=2/3V_{DRM}$ Gate Open $T_j=125^\circ C$		MIN	200	500	$V/\mu s$

STATIC CHARACTERISTICS

Symbol	Parameter		Value(MAX)	Unit
V_{TM}	$I_{TM} = 11A$ $t_p = 380\mu s$	$T_j = 25^\circ C$	1.5	V
I_{DRM}	$V_D = V_{DRM}$ $V_R = V_{RRM}$	$T_j = 25^\circ C$	5	μA
I_{RRM}		$T_j = 125^\circ C$	1	mA

THERMAL RESISTANCES

Symbol	Parameter		Value	Unit
$R_{th(j-c)}$	junction to case(AC)	TO-252-4R/ TO-251-4R	2.1	$^\circ C/W$
		TO-220A(Ins)	2.7	
		TO-220B(Non-Ins)	1.8	
		TO-220F(Ins)	2.9	
		TO-262/TO-263	3.0	

ORDERING INFORMATION

<p>JieJie Microelectronics Co.,Ltd</p> <p>Triacs</p> <p>$I_{T(RMS)}: 8A$</p> <p>E:TO-263 B:TO-220B(Non-Ins) A:TO-220A(Ins) F:TO-220F(Ins) H:TO-251-4R K:TO-252-4R D:TO-262</p>	<p>J ST 08 D -800 TW</p> <p>TW: $I_{GT1-3} \leq 5mA$ SW: $I_{GT1-3} \leq 10mA$ CW: $I_{GT1-3} \leq 35mA$ BW: $I_{GT1-3} \leq 50mA$ C: $I_{GT1-3} \leq 25mA$ $I_{GT4} \leq 50mA$ B: $I_{GT1-3} \leq 50mA$ $I_{GT4} \leq 70mA$</p> <p>600: $V_{DRM} / V_{RRM} \geq 600V$ 800: $V_{DRM} / V_{RRM} \geq 800V$ 1200: $V_{DRM} / V_{RRM} \geq 1200V$</p>
---	--

PACKAGE MECHANICAL DATA

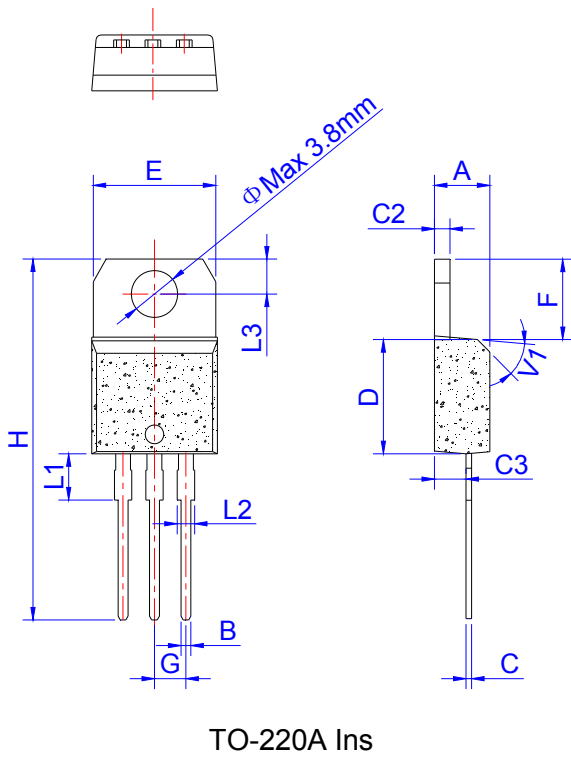

Ref.	Dimensions					
	Millimeters			Inches		
	Min.	Typ.	Max.	Min.	Typ.	Max.
A	4.40		4.60	0.173		0.181
B	0.61		0.88	0.024		0.035
C	0.46		0.70	0.018		0.028
C2	1.21		1.32	0.048		0.052
C3	2.40		2.72	0.094		0.107
D	8.60		9.70	0.339		0.382
E	9.80		10.4	0.386		0.409
F	6.55		6.95	0.258		0.274
G		2.54			0.1	
H	28.0		29.8	1.102		1.173
L1		3.75			0.148	
L2	1.14		1.70	0.045		0.067
L3	2.65		2.95	0.104		0.116
V1		45°			45°	

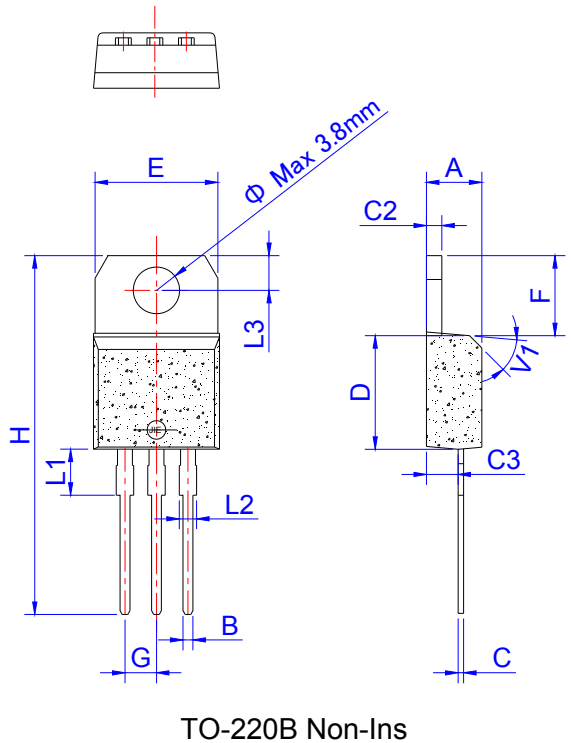

Ref.	Dimensions					
	Millimeters			Inches		
	Min.	Typ.	Max.	Min.	Typ.	Max.
A	4.40		4.60	0.173		0.181
B	0.61		0.88	0.024		0.035
C	0.46		0.70	0.018		0.028
C2	1.21		1.32	0.048		0.052
C3	2.40		2.72	0.094		0.107
D	8.60		9.70	0.339		0.382
E	9.60		10.4	0.378		0.409
F	6.20		6.60	0.244		0.260
G		2.54			0.1	
H	28.0		29.8	1.102		1.173
L1		3.75			0.148	
L2	1.14		1.70	0.045		0.067
L3	2.65		2.95	0.104		0.116
V1		45°			45°	

PACKAGE MECHANICAL DATA

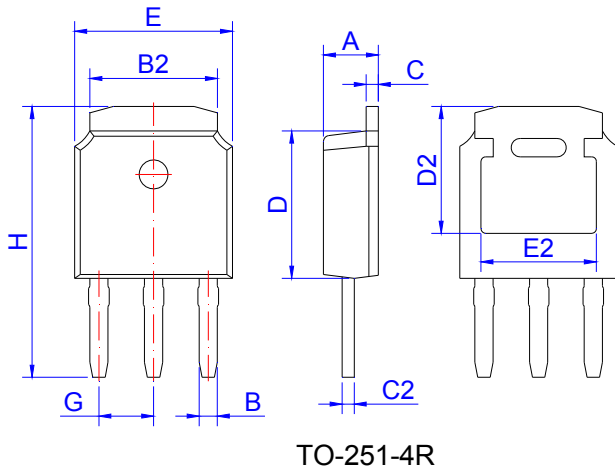

Ref.	Dimensions					
	Millimeters			Inches		
	Min.	Typ.	Max.	Min.	Typ.	Max.
A	2.10	2.30	2.50	0.083	0.091	0.098
B	0.66	0.76	0.86	0.026	0.030	0.034
B2	5.15	5.33	5.48	0.203	0.210	0.216
C	0.44	0.51	0.58	0.017	0.020	0.023
C2	0.44	0.51	0.58	0.017	0.020	0.023
D	5.90	6.10	6.30	0.232	0.240	0.248
D2	5.30 REF			0.209 REF		
E	6.40	6.60	6.80	0.252	0.260	0.268
E2	4.83 REF			0.190 REF		
G	2.19	2.29	2.39	0.086	0.090	0.094
H	10.60	11.20	11.80	0.417	0.441	0.465

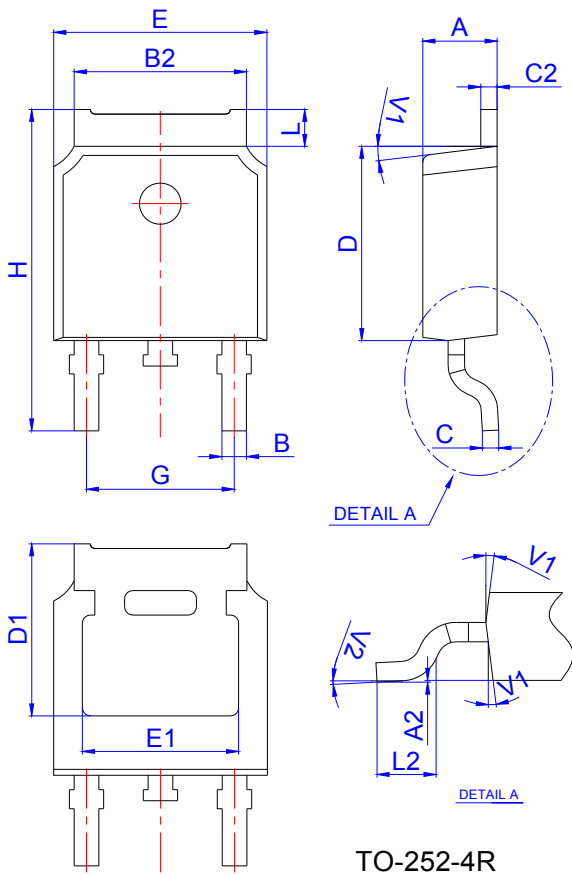

Ref.	Dimensions					
	Millimeters			Inches		
	Min.	Typ.	Max.	Min.	Typ.	Max.
A	2.10		2.50	0.083		0.098
A2	0		0.10	0		0.004
B	0.66		0.86	0.026		0.034
B2	5.18		5.48	0.202		0.216
C	0.40		0.60	0.016		0.024
C2	0.44		0.58	0.017		0.023
D	5.90		6.30	0.232		0.248
D1	5.30REF			0.209REF		
E	6.40		6.80	0.252		0.268
E1	4.63			0.182		
G	4.47		4.67	0.176		0.184
H	9.50		10.70	0.374		0.421
L	1.09		1.21	0.043		0.048
L2	1.35		1.65	0.053		0.065
V1		7°			7°	
V2	0°		6°	0°		6°

PACKAGE MECHANICAL DATA

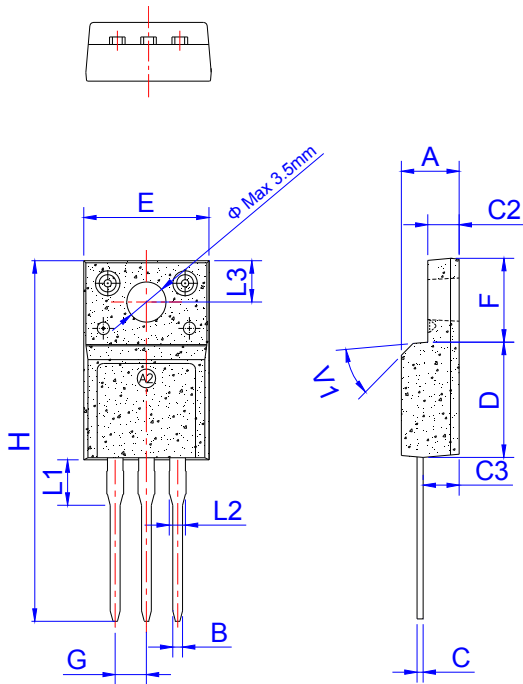

TO-220F Ins

Ref.	Dimensions					
	Millimeters			Inches		
	Min.	Typ.	Max.	Min.	Typ.	Max.
A	4.50		4.90	0.177		0.193
B	0.74	0.80	0.83	0.029	0.031	0.033
C	0.47		0.65	0.019		0.026
C2	2.45		2.75	0.096		0.108
C3	2.60		3.00	0.102		0.118
D	8.80		9.30	0.346		0.366
E	9.80		10.4	0.386		0.410
F	6.40		6.80	0.252		0.268
G		2.54			0.1	
H	28.0		29.8	1.102		1.173
L1		3.63			0.143	
L2	1.14		1.70	0.045		0.067
L3		3.30			0.130	
V1		45°			45°	

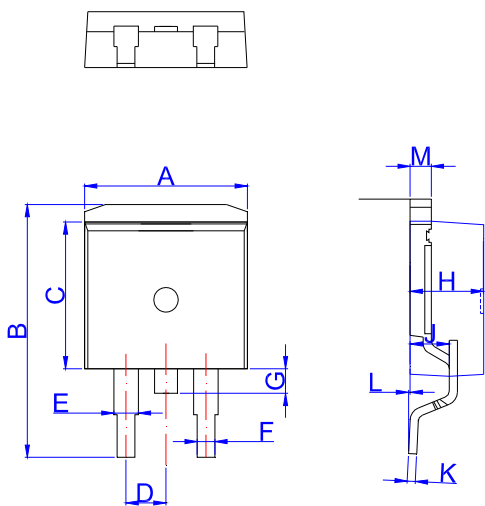

TO-263

Ref.	Dimensions					
	Millimeters			Inches		
	Min.	Typ.	Max.	Min.	Typ.	Max.
A	9.90		10.20	0.390		0.402
B	14.70		15.80	0.579		0.622
C	9.4		9.6	0.37		0.378
D		2.54			0.100	
E	1.20		1.40	0.047		0.055
F	0.75		0.85	0.029		0.033
G			1.75			0.069
H	4.40		4.70	0.173		0.185
J	2.30		2.70	0.091		0.106
K	0.38		0.55	0.015		0.022
L	0	0.10	0.25	0	0.004	0.010
M	1.25		1.35	0.049		0.053

PACKAGE MECHANICAL DATA

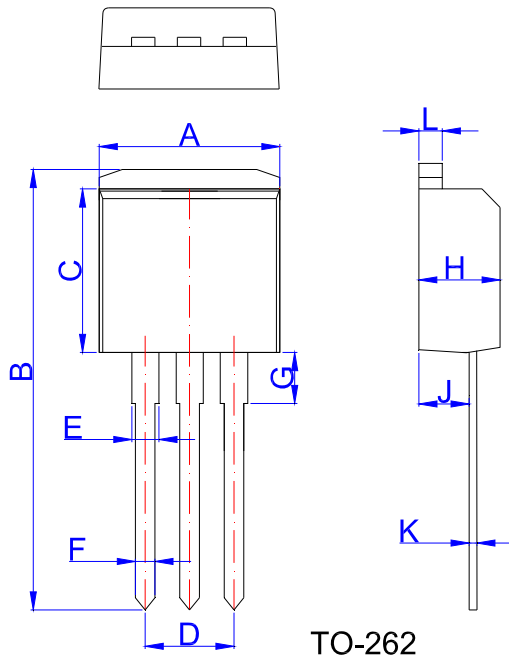

Ref.	Dimensions					
	Millimeters			Inches		
	Min.	Typ.	Max.	Min.	Typ.	Max.
A	9.95		10.20	0.392		0.402
B	23.25		23.45	0.915		0.923
C	8.90		9.10	0.35		0.358
D	2.50		2.60	0.098		0.102
E	1.20		1.35	0.047		0.053
F	0.80		0.85	0.031		0.033
G	3.30		3.60	0.130		0.142
H	4.45		4.55	0.175		0.179
J	2.50		2.70	0.098		0.106
K	0.38		0.42	0.015		0.017
L	1.25		1.29	0.049		0.051

FIG.1: Maximum power dissipation versus RMS on-state current

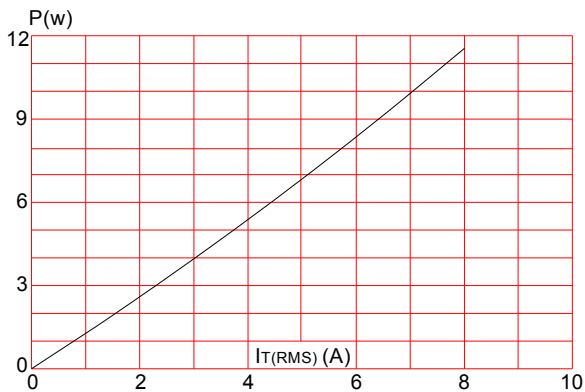

FIG.3: Surge peak on-state current versus number of cycles

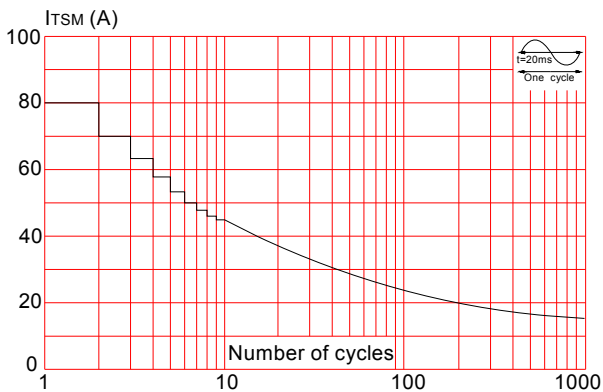

FIG.2: RMS on-state current versus case temperature

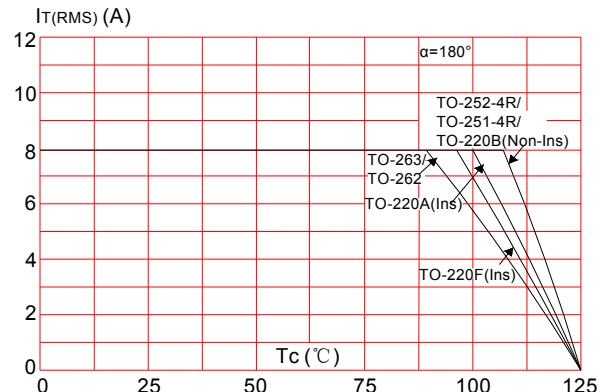

FIG.4: On-state characteristics (maximum values)

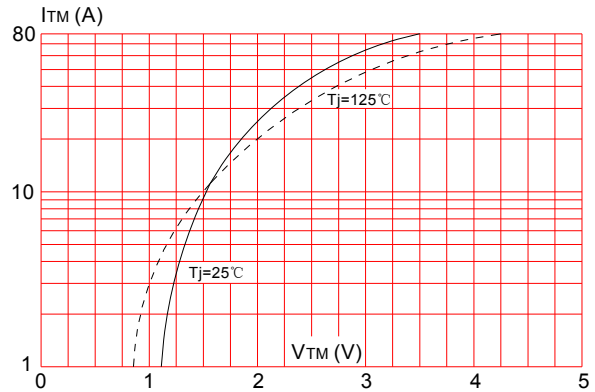

FIG.5: Non-repetitive surge peak on-state current for a sinusoidal pulse with width $t_p < 20\text{ms}$, and corresponding value of I^2t ($di/dt < 50\text{A}/\mu\text{s}$)

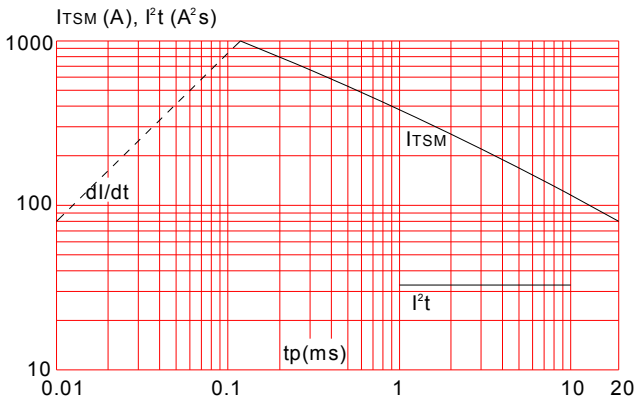
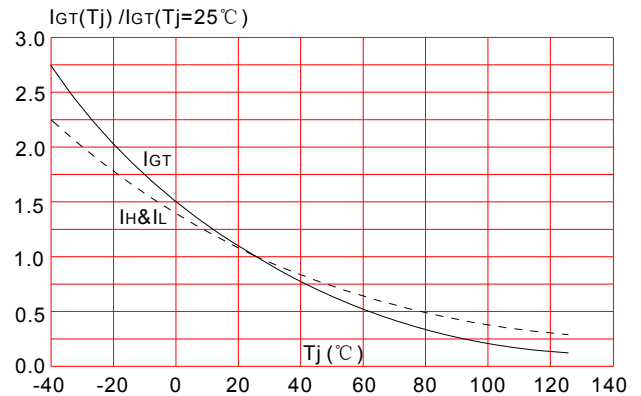



FIG.6: Relative variations of gate trigger current, holding current and latching current versus junction temperature



Information furnished in this document is believed to be accurate and reliable. However, Jiangsu JieJie Microelectronics Co.,Ltd assumes no responsibility for the consequences of use without consideration for such information nor use beyond it. Information mentioned in this document is subject to change without notice, apart from that when an agreement is signed, Jiangsu JieJie complies with the agreement. Products and information provided in this document have no infringement of patents. Jiangsu JieJie assumes no responsibility for any infringement of other rights of third parties which may result from the use of such products and information. This document is the eighth version which is made in 22-Feb.-2018. This document supersedes and replaces all information previously supplied.

 is a registered trademark of Jiangsu JieJie Microelectronics Co.,Ltd.

Copyright ©2018 Jiangsu JieJie Microelectronics Co.,Ltd. Printed All rights reserved.