

GigaDevice Semiconductor Inc.

GD32E103xx

ARM[®] Cortex[®]-M4 32-bit MCU

Datasheet

Table of Contents

Table of Contents.....	1
List of Figures.....	3
List of Tables.....	4
1. General description	5
2. Device overview	6
2.1. Device information	6
2.2. Block diagram.....	7
2.3. Pinouts and pin assignment	8
2.4. Memory map	10
2.5. Clock tree	14
2.6. Pin definitions.....	15
2.6.1. GD32E103Vx LQFP100 pin definitions	15
2.6.2. GD32E103Rx LQFP64 pin definitions	21
2.6.3. GD32E103Cx LQFP48 pin definitions	25
2.6.4. GD32E103Tx QFN36 pin definitions	28
3. Functional description	31
3.1. ARM® Cortex™-M4 core	31
3.2. On-chip memory	31
3.3. Clock, reset and supply management.....	32
3.4. Boot modes.....	32
3.5. Power saving modes	33
3.6. Analog to digital converter (ADC)	33
3.7. Digital to analog converter (DAC).....	34
3.8. DMA	34
3.9. General-purpose inputs/outputs (GPIOs)	34
3.10. Timers and PWM generation	35
3.11. Real time clock (RTC)	36
3.12. Inter-integrated circuit (I2C)	36
3.13. Serial peripheral interface (SPI)	36
3.14. Universal synchronous asynchronous receiver transmitter (USART)	37
3.15. Inter-IC sound (I2S)	37

3.16.	Universal serial bus full-speed interface (USBFS).....	37
3.17.	Controller area network (CAN).....	38
3.18.	External memory controller (EXMC).....	38
3.19.	Debug mode.....	38
3.20.	Package and operation temperature.....	39
4.	Electrical characteristics.....	40
4.1.	Absolute maximum ratings.....	40
4.2.	Recommended DC characteristics.....	40
4.3.	Power consumption.....	40
4.4.	EMC characteristics.....	42
4.5.	Power supply supervisor characteristics.....	43
4.6.	Electrical sensitivity.....	44
4.7.	External clock characteristics.....	44
4.8.	Internal clock characteristics.....	46
4.9.	PLL characteristics.....	47
4.10.	Memory characteristics.....	47
4.11.	GPIO characteristics.....	47
4.12.	ADC characteristics.....	49
4.13.	DAC characteristics.....	50
4.14.	I2C characteristics.....	51
4.15.	SPI characteristics.....	51
5.	Package information.....	53
5.1.	QFN package outline dimensions.....	53
5.2.	LQFP package outline dimensions.....	53
6.	Ordering information.....	56
7.	Revision history.....	57

List of Figures

Figure 2-1. GD32E103xx block diagram	7
Figure 2-2. GD32E103Vx LQFP100 pinouts	8
Figure 2-3. GD32E103Rx LQFP64 pinouts	9
Figure 2-3. GD32E103Cx LQFP48 pinouts	9
Figure 2-3. GD32E103Tx QFN36 pinouts.....	10
Figure 2-5. GD32E103xx clock tree.....	14
Figure 5-1. QFN package outline.....	53
Figure 5-1. LQFP package outline.....	53

List of Tables

Table 2-1. GD32E103xx devices features and peripheral list.....	6
Table 2-2. GD32E103xx memory map.....	10
Table 2-3. GD32E103Vx LQFP100 pin definitions.....	15
Table 4-1. Absolute maximum ratings.....	40
Table 4-2. DC operating conditions	40
Table 4-3. Power consumption characteristics	40
Table 4-4. EMS characteristics.....	42
Table 4-5. EMI characteristics	42
Table 4-6. Power supply supervisor characteristics.....	43
Table 4-7. ESD characteristics	44
Table 4-8. Static latch-up characteristics.....	44
Table 4-9. High speed external clock (HXTAL) generated from a crystal/ceramic characteristics...	44
Table 5-1. QFN package dimensions	53
Table 5-2. LQFP package dimensions	54
Table 6-1. Part ordering code for GD32E103xx devices	56
Table 7-1. Revision history	57

1. General description

The GD32E103xx device belongs to the connectivity line of GD32 MCU Family. It is a 32-bit general-purpose microcontroller based on the ARM® Cortex®-M4 RISC core with best cost-performance ratio in terms of enhanced processing capacity, reduced power consumption and peripheral set. The Cortex®-M4 core features implements a full set of DSP instructions to address digital signal control markets that demand an efficient, easy-to-use blend of control and signal processing capabilities. It also provides powerful trace technology for enhanced application security and advanced debug support.

The GD32E103xx device incorporates the ARM® Cortex®-M4 32-bit processor core operating at 120 MHz frequency with Flash accesses zero wait states to obtain maximum efficiency. It provides up to 128 KB on-chip Flash memory and 32 KB SRAM memory. An extensive range of enhanced I/Os and peripherals connected to two APB buses. The devices offer up to two 12-bit 3 MSPS ADCs, a 12-bit DAC, up to ten general 16-bit timers, two 16-bit PWM advanced timers, and two 16-bit basic timers, as well as standard and advanced communication interfaces: up to three SPIs, two I2Cs, three USARTs and two UARTs, two I2Ss, an USBFS and two CANs.

The device operates from a 1.8 to 3.6 V power supply and available in –40 to +85 °C temperature range. Several power saving modes provide the flexibility for maximum optimization between wakeup latency and power consumption, an especially important consideration in low power applications.

The above features make GD32E103xx devices suitable for a wide range of interconnection and advanced applications, especially in areas such as industrial control, motor drives, consumer and handheld equipment, human machine interface, security and alarm systems, POS, automotive navigation, IoT and so on.



2. Device overview

2.1. Device information

Table 2-1.GD32E103xx devices features and peripheral list

Part Number		GD32E103xx							
		T8	TB	C8	CB	R8	RB	V8	VB
Flash (KB)		64	128	64	128	64	128	64	128
SRAM (KB)		20	32	20	32	20	32	20	20
Timers	General timer(16-bit)	4 <small>(1-4)</small>	4 <small>(1-4)</small>	10 <small>(1-4,8-13)</small>	10 <small>(1-4,8-13)</small>	10 <small>(1-4,8-13)</small>	10 <small>(1-4,8-13)</small>	10 <small>(1-4,8-13)</small>	10 <small>(1-4,8-13)</small>
	Advanced timer(16-bit)	1 <small>(0)</small>	1 <small>(0)</small>	1 <small>(0)</small>	1 <small>(0)</small>	2 <small>(0,7)</small>	2 <small>(0,7)</small>	2 <small>(0,7)</small>	2 <small>(0,7)</small>
	SysTick	1	1	1	1	1	1	1	1
	Basic timer(16-bit)	2 <small>(5,6)</small>	2 <small>(5,6)</small>	2 <small>(5,6)</small>	2 <small>(5,6)</small>	2 <small>(5,6)</small>	2 <small>(5,6)</small>	2 <small>(5,6)</small>	2 <small>(5,6)</small>
	Watchdog	2	2	2	2	2	2	2	2
	RTC	1	1	1	1	1	1	1	1
Connectivity	USART	2 <small>(0-1)</small>	2 <small>(0-1)</small>	3 <small>(0-2)</small>	3 <small>(0-2)</small>	3 <small>(0-2)</small>	3 <small>(0-2)</small>	3 <small>(0-2)</small>	3 <small>(0-2)</small>
	UART	0	0	0	0	2 <small>(3-4)</small>	2 <small>(3-4)</small>	2 <small>(3-4)</small>	2 <small>(3-4)</small>
	I2C	1 <small>(0)</small>	1 <small>(0)</small>	2 <small>(0-1)</small>	2 <small>(0-1)</small>	2 <small>(0-1)</small>	2 <small>(0-1)</small>	2 <small>(0-1)</small>	2 <small>(0-1)</small>
	SPI	1/0 <small>(0-)</small>	1/0 <small>(0-)</small>	3/2 <small>(0-2)/(1-2)</small>	3/2 <small>(0-2)/(1-2)</small>	3/2 <small>(0-2)/(1-2)</small>	3/2 <small>(0-2)/(1-2)</small>	3/2 <small>(0-2)/(1-2)</small>	3/2 <small>(0-2)/(1-2)</small>
	CAN	2xFD	2xFD	2xFD	2xFD	2xFD	2xFD	2xFD	2xFD
	USBFS	1	1	1	1	1	1	1	1
GPIO		26	26	37	37	51	51	80	80
EXMC		0	0	0	0	0	0	1	1
EXTI		16	16	16	16	16	16	16	16
ADC	Units	2	2	2	2	2	2	2	2
	Channels	10	10	10	10	16	16	16	16
Package		QFN36		LQFP48		LQFP64		LQFP100	

2.2. Block diagram

Figure 2-1.GD32E103xx block diagram

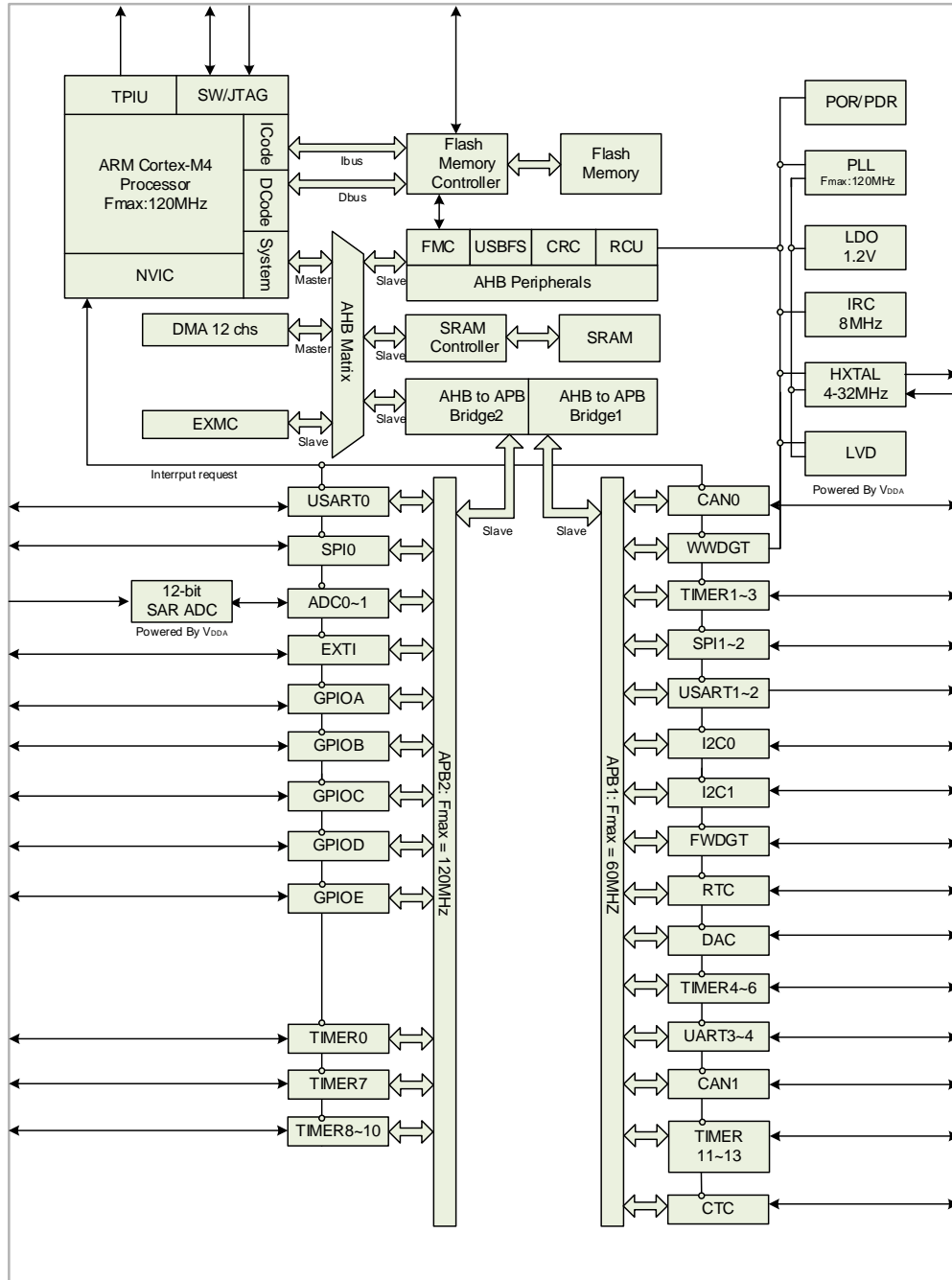

2.3. Pinouts and pin assignment

Figure 2-2. GD32E103Vx LQFP100 pinouts

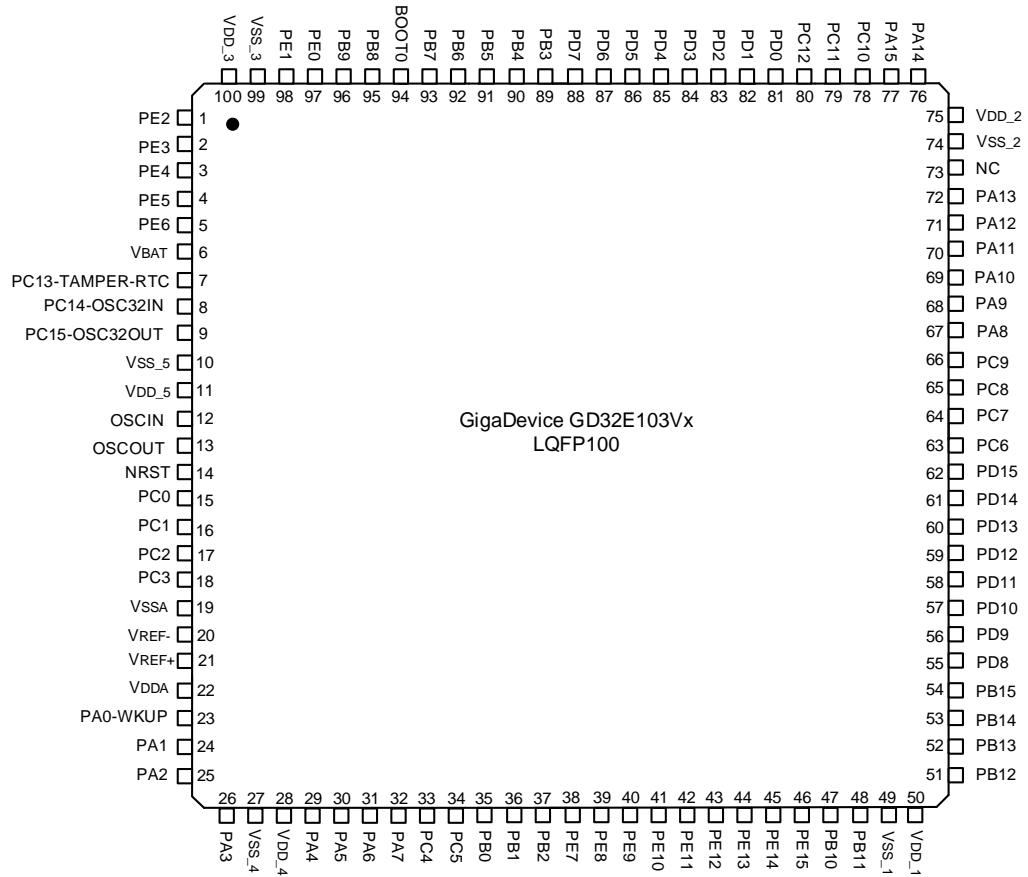

Figure 2-3. GD32E103Rx LQFP64 pinouts

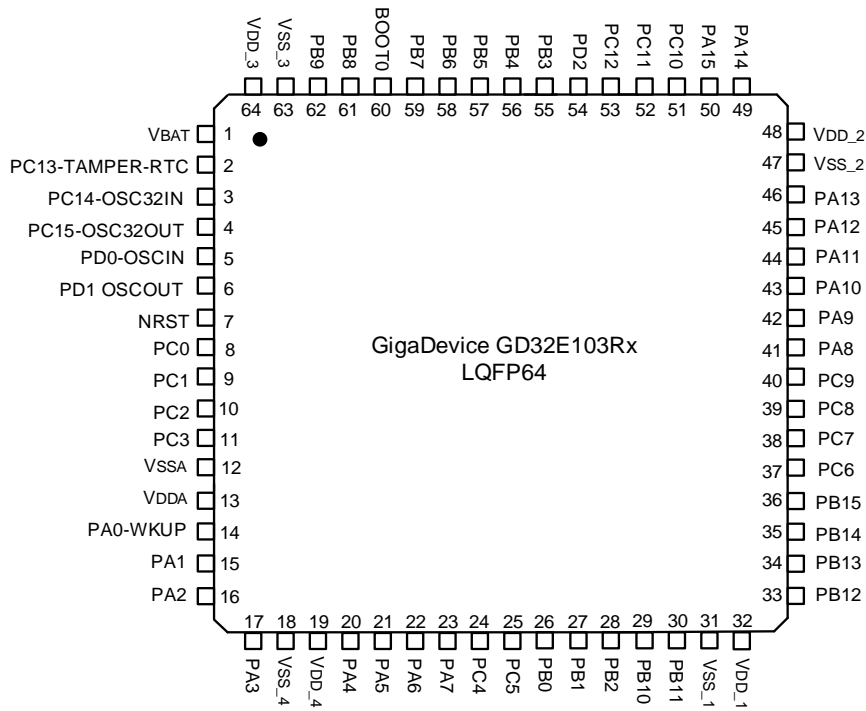

Figure 2-4. GD32E103Cx LQFP48 pinouts

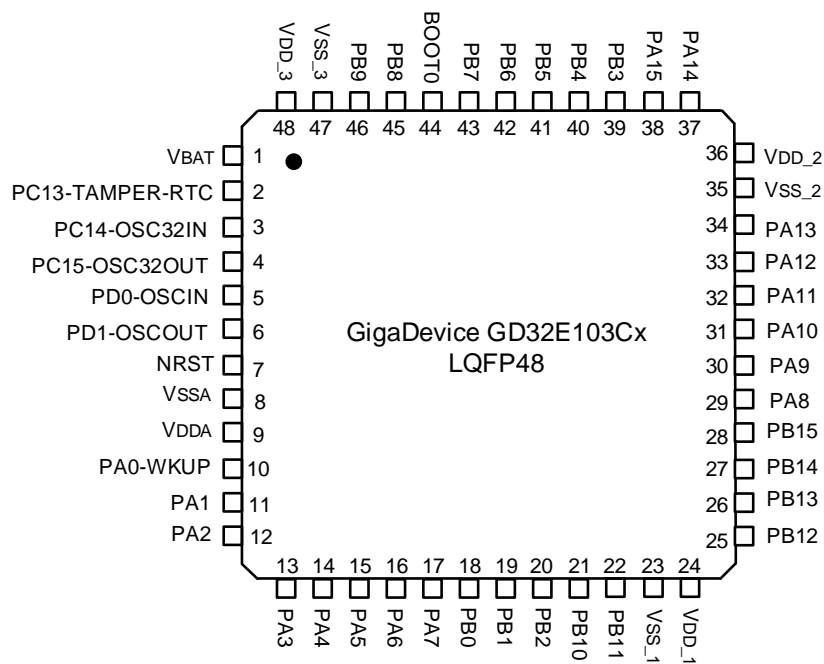
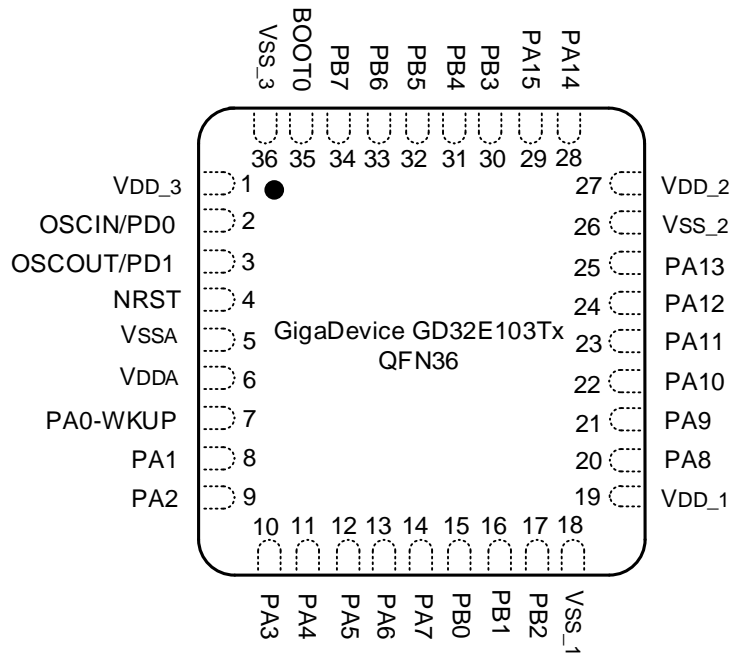

Figure 2-5. GD32E103Tx QFN36 pinouts



2.4. Memory map

Table 2-2. GD32E103xx memory map

Pre-defined regions	Bus	Address	Peripherals
External device	AHB3	0xA000 0000 - 0xA000 0FFF	EXMC - SWREG
External RAM		0x9000 0000 - 0x9FFF FFFF	Reserved
		0x7000 0000 - 0x8FFF FFFF	Reserved
		0x6000 0000 - 0x63FF FFFF	EXMC - NOR/PSRAM/SRAM
Peripheral	AHB1	0x5000 0000 - 0x5003 FFFF	USBFS
		0x4008 0000 - 0x4FFF FFFF	Reserved
		0x4004 0000 - 0x4007 FFFF	Reserved
		0x4002 BC00 - 0x4003 FFFF	Reserved
		0x4002 B000 - 0x4002 BBFF	Reserved
		0x4002 A000 - 0x4002 AFFF	Reserved
		0x4002 8000 - 0x4002 9FFF	Reserved
		0x4002 6800 - 0x4002 7FFF	Reserved
		0x4002 6400 - 0x4002 67FF	Reserved
		0x4002 6000 - 0x4002 63FF	Reserved
		0x4002 5000 - 0x4002 5FFF	Reserved

Pre-defined regions	Bus	Address	Peripherals
		0x4002 4000 - 0x4002 4FFF	Reserved
		0x4002 3C00 - 0x4002 3FFF	Reserved
		0x4002 3800 - 0x4002 3BFF	Reserved
		0x4002 3400 - 0x4002 37FF	Reserved
		0x4002 3000 - 0x4002 33FF	CRC
		0x4002 2C00 - 0x4002 2FFF	Reserved
		0x4002 2800 - 0x4002 2BFF	Reserved
		0x4002 2400 - 0x4002 27FF	Reserved
		0x4002 2000 - 0x4002 23FF	FMC
		0x4002 1C00 - 0x4002 1FFF	Reserved
		0x4002 1800 - 0x4002 1BFF	Reserved
		0x4002 1400 - 0x4002 17FF	Reserved
		0x4002 1000 - 0x4002 13FF	RCU
		0x4002 0C00 - 0x4002 0FFF	Reserved
		0x4002 0800 - 0x4002 0BFF	Reserved
		0x4002 0400 - 0x4002 07FF	DMA1
		0x4002 0000 - 0x4002 03FF	DMA0
		0x4001 8400 - 0x4001 FFFF	Reserved
		0x4001 8000 - 0x4001 83FF	Reserved
	APB2	0x4001 7C00 - 0x4001 7FFF	Reserved
		0x4001 7800 - 0x4001 7BFF	Reserved
		0x4001 7400 - 0x4001 77FF	Reserved
		0x4001 7000 - 0x4001 73FF	Reserved
		0x4001 6C00 - 0x4001 6FFF	Reserved
		0x4001 6800 - 0x4001 6BFF	Reserved
		0x4001 5C00 - 0x4001 67FF	Reserved
		0x4001 5800 - 0x4001 5BFF	Reserved
		0x4001 5400 - 0x4001 57FF	TIMER10
		0x4001 5000 - 0x4001 53FF	TIMER9
		0x4001 4C00 - 0x4001 4FFF	TIMER8
		0x4001 4800 - 0x4001 4BFF	Reserved
		0x4001 4400 - 0x4001 47FF	Reserved
		0x4001 4000 - 0x4001 43FF	Reserved
		0x4001 3C00 - 0x4001 3FFF	Reserved
		0x4001 3800 - 0x4001 3BFF	USART0
		0x4001 3400 - 0x4001 37FF	TIMER7
		0x4001 3000 - 0x4001 33FF	SPI0
		0x4001 2C00 - 0x4001 2FFF	TIMER0
		0x4001 2800 - 0x4001 2BFF	ADC1
	0x4001 2400 - 0x4001 27FF	ADC0	

Pre-defined regions	Bus	Address	Peripherals
		0x4001 2000 - 0x4001 23FF	Reserved
		0x4001 1C00 - 0x4001 1FFF	Reserved
		0x4001 1800 - 0x4001 1BFF	GPIOE
		0x4001 1400 - 0x4001 17FF	GIOD
		0x4001 1000 - 0x4001 13FF	GPIOC
		0x4001 0C00 - 0x4001 0FFF	GPIOB
		0x4001 0800 - 0x4001 0BFF	GPIOA
		0x4001 0400 - 0x4001 07FF	EXTI
		0x4001 0000 - 0x4001 03FF	AFIO
	APB1	0x4000 CC00 - 0x4000 FFFF	Reserved
		0x4000 C800 - 0x4000 CBFF	CTC
		0x4000 C400 - 0x4000 C7FF	Reserved
		0x4000 C000 - 0x4000 C3FF	Reserved
		0x4000 8000 - 0x4000 BFFF	Reserved
		0x4000 7C00 - 0x4000 7FFF	Reserved
		0x4000 7800 - 0x4000 7BFF	Reserved
		0x4000 7400 - 0x4000 77FF	DAC
		0x4000 7000 - 0x4000 73FF	PMU
		0x4000 6C00 - 0x4000 6FFF	BKP
		0x4000 6800 - 0x4000 6BFF	CAN1
		0x4000 6400 - 0x4000 67FF	CAN0
		0x4000 6000 - 0x4000 63FF	CAN SRAM 1K bytes
		0x4000 5C00 - 0x4000 5FFF	Reserved
		0x4000 5800 - 0x4000 5BFF	I2C1
		0x4000 5400 - 0x4000 57FF	I2C0
		0x4000 5000 - 0x4000 53FF	UART4
		0x4000 4C00 - 0x4000 4FFF	UART3
		0x4000 4800 - 0x4000 4BFF	USART2
		0x4000 4400 - 0x4000 47FF	USART1
		0x4000 4000 - 0x4000 43FF	Reserved
		0x4000 3C00 - 0x4000 3FFF	SPI2/I2S2
		0x4000 3800 - 0x4000 3BFF	SPI1/I2S1
0x4000 3400 - 0x4000 37FF	Reserved		
0x4000 3000 - 0x4000 33FF	FWDGT		
0x4000 2C00 - 0x4000 2FFF	WWDGT		
0x4000 2800 - 0x4000 2BFF	RTC		
0x4000 2400 - 0x4000 27FF	Reserved		
0x4000 2000 - 0x4000 23FF	TIMER13		

Pre-defined regions	Bus	Address	Peripherals
		0x4000 1C00 - 0x4000 1FFF	TIMER12
		0x4000 1800 - 0x4000 1BFF	TIMER11
		0x4000 1400 - 0x4000 17FF	TIMER6
		0x4000 1000 - 0x4000 13FF	TIMER5
		0x4000 0C00 - 0x4000 0FFF	TIMER4
		0x4000 0800 - 0x4000 0BFF	TIMER3
		0x4000 0400 - 0x4000 07FF	TIMER2
		0x4000 0000 - 0x4000 03FF	TIMER1
SRAM	AHB	0x2007 0000 - 0x3FFF FFFF	Reserved
		0x2006 0000 - 0x2006 FFFF	Reserved
		0x2003 0000 - 0x2005 FFFF	Reserved
		0x2002 0000 - 0x2002 FFFF	Reserved
		0x2001 C000 - 0x2001 FFFF	SRAM
		0x2001 8000 - 0x2001 BFFF	
		0x2000 5000 - 0x2001 7FFF	
		0x2000 0000 - 0x2000 4FFF	
Code	AHB	0x1FFF F810 - 0x1FFF FFFF	Reserved
		0x1FFF F800 - 0x1FFF F80F	Option Bytes
		0x1FFF F000 - 0x1FFF F7FF	Boot loader
		0x1FFF C010 - 0x1FFF EFFF	
		0x1FFF C000 - 0x1FFF C00F	
		0x1FFF B000 - 0x1FFF BFFF	
		0x1FFF 7A10 - 0x1FFF AFFF	
		0x1FFF 7800 - 0x1FFF 7A0F	Reserved
		0x1FFF 0000 - 0x1FFF 77FF	Reserved
		0x1FFE C010 - 0x1FFE FFFF	Reserved
		0x1FFE C000 - 0x1FFE C00F	Reserved
		0x1001 0000 - 0x1FFE BFFF	Reserved
		0x1000 0000 - 0x1000 FFFF	Reserved
		0x083C 0000 - 0x0FFF FFFF	Reserved
		0x0830 0000 - 0x083B FFFF	Reserved
		0x0810 0000 - 0x082F FFFF	Main Flash
		0x0802 0000 - 0x080F FFFF	
		0x0800 0000 - 0x0801 FFFF	
		0x0030 0000 - 0x07FF FFFF	Reserved
		0x0010 0000 - 0x002F FFFF	Aliased to Main Flash or Boot loader
		0x0002 0000 - 0x000F FFFF	
		0x0000 0000 - 0x0001 FFFF	

2.6. Pin definitions

2.6.1. GD32E103Vx LQFP100 pin definitions

Table 2-3. GD32E103Vx LQFP100 pin definitions

Pin Name	Pins	Pin Type ⁽¹⁾	I/O Level ⁽²⁾	Functions description
PE2	1	I/O	5VT	Default: PE2 Alternate: TRACECK, EXMC_A23
PE3	2	I/O	5VT	Default: PE3 Alternate: TRACED0, EXMC_A19
PE4	3	I/O	5VT	Default: PE4 Alternate: TRACED1, EXMC_A20
PE5	4	I/O	5VT	Default: PE5 Alternate: TRACED2, EXMC_A21 Remap: TIMER8_CH0
PE6	5	I/O	5VT	Default: PE6 Alternate:TRACED3, EXMC_A22 Remap:TIMER8_CH1
V _{BAT}	6	P	-	Default: V _{BAT}
PC13- TAMPER- RTC	7	I/O	-	Default: PC13 Alternate: RTC_TAMPER
PC14- OSC32IN	8	I/O	-	Default: PC14 Alternate:OSC32IN
PC15- OSC32O UT	9	I/O	-	Default: PC15 Alternate:OSC32OUT
V _{SS_5}	10	P	-	Default: V _{SS_5}
V _{DD_5}	11	P	-	Default: V _{DD_5}
OSCIN	12	I	-	Default: OSCIN Remap:PD0
OSCOUT	13	O	-	Default: OSCOUT Remap:PD1
NRST	14	I/O	-	Default: NRST
PC0	15	I/O	-	Default: PC0 Alternate: ADC01_IN10
PC1	16	I/O	-	Default: PC1 Alternate: ADC01_IN11
PC2	17	I/O	-	Default: PC2 Alternate: ADC01_IN12

Pin Name	Pins	Pin Type ⁽¹⁾	I/O Level ⁽²⁾	Functions description
PC3	18	I/O	-	Default: PC3 Alternate: ADC01_IN13
V _{SSA}	19	P	-	Default: V _{SSA}
V _{REF-}	20	P	-	Default: V _{REF-}
V _{REF+}	21	P	-	Default: V _{REF+}
V _{DDA}	22	P	-	Default: V _{DDA}
PA0- WK UP	23	I/O	-	Default: PA0 Alternate: WKUP, USART1_CTS, ADC01_IN0, TIMER1_CH0_ETI, TIMER4_CH0, TIMER7_ETI
PA1	24	I/O	-	Default: PA1 Alternate: USART1_RTS, ADC01_IN1, TIMER4_CH1, TIMER1_CH1
PA2	25	I/O	-	Default: PA2 Alternate: USART1_TX, TIMER4_CH2, ADC01_IN2, TIMER8_CH0, TIMER1_CH2, SPI0_IO2
PA3	26	I/O	-	Default: PA3 Alternate: USART1_RX, TIMER4_CH3, ADC01_IN3, TIMER1_CH3, TIMER8_CH1, SPI0_IO3
V _{SS_4}	27	P	-	Default: V _{SS_4}
V _{DD_4}	28	P	-	Default: V _{DD_4}
PA4	29	I/O	-	Default: PA4 Alternate: SPI0_NSS, USART1_CK, DAC_OUT0, ADC01_IN4 Remap:SPI2_NSS, I2S2_WS
PA5	30	I/O	-	Default: PA5 Alternate: SPI0_SCK, ADC01_IN5, DAC_OUT1
PA6	31	I/O	-	Default: PA6 Alternate: SPI0_MISO, TIMER7_BKIN, ADC01_IN6, TIMER2_CH0, TIMER12_CH0 Remap:TIMER0_BKIN
PA7	32	I/O	-	Default: PA7 Alternate: SPI0_MOSI, TIMER7_CH0_ON, ADC01_IN7, TIMER2_CH1, TIMER13_CH0 Remap:TIMER0_CH0_ON
PC4	33	I/O	-	Default: PC4 Alternate: ADC01_IN14
PC5	34	I/O	-	Default: PC5 Alternate: ADC01_IN15
PB0	35	I/O	-	Default: PB0 Alternate: ADC01_IN8, TIMER2_CH2, TIMER7_CH1_ON Remap:TIMER0_CH1_ON

Pin Name	Pins	Pin Type ⁽¹⁾	I/O Level ⁽²⁾	Functions description
PB1	36	I/O	-	Default: PB1 Alternate: ADC01_IN9, TIMER2_CH3, TIMER7_CH2_ON Remap:TIMER0_CH2_ON
PB2	37	I/O	5VT	Default: PB2, BOOT1
PE7	38	I/O	5VT	Default: PE7 Alternate: EXMC_D4 Remap: TIMER0_ETI
PE8	39	I/O	5VT	Default: PE8 Alternate: EXMC_D5 Remap: TIMER0_CH0_ON
PE9	40	I/O	5VT	Default: PE9 Alternate: EXMC_D6 Remap:TIMER0_CH0
PE10	41	I/O	5VT	Default: PE10 Alternate: EXMC_D7 Remap:TIMER0_CH1_ON
PE11	42	I/O	5VT	Default: PE11 Alternate: EXMC_D8 Remap:TIMER0_CH1
PE12	43	I/O	5VT	Default: PE12 Alternate: EXMC_D9 Remap:TIMER0_CH2_ON
PE13	44	I/O	5VT	Default: PE13 Alternate: EXMC_D10 Remap:TIMER0_CH2
PE14	45	I/O	5VT	Default: PE14 Alternate: EXMC_D11 Remap:TIMER0_CH3
PE15	46	I/O	5VT	Default: PE15 Alternate: EXMC_D12 Remap:TIMER0_BKIN
PB10	47	I/O	5VT	Default: PB10 Alternate:I2C1_SCL, USART2_TX Remap: TIMER1_CH2
PB11	48	I/O	5VT	Default: PB11 Alternate:I2C1_SDA, USART2_RX Remap: TIMER1_CH3
V _{SS_1}	49	P	-	Default:V _{SS_1}
V _{DD_1}	50	P	-	Default:V _{DD_1}

Pin Name	Pins	Pin Type ⁽¹⁾	I/O Level ⁽²⁾	Functions description
PB12	51	I/O	5VT	Default: PB12 Alternate: SPI1_NSS, I2S1_WS, I2C1_SMBA, USART2_CK, TIMER0_BKIN, CAN1_RX
PB13	52	I/O	5VT	Default: PB13 Alternate: SPI1_SCK, I2S1_CK, USART2_CTS, TIMER0_CH0_ON, CAN1_TX, I2C1_TXFRAME
PB14	53	I/O	5VT	Default: PB14 Alternate: SPI1_MISO, USART2_RTS, TIMER0_CH1_ON, TIMER11_CH0
PB15	54	I/O	5VT	Default: PB15 Alternate: SPI1_MOSI, I2S1_SD, TIMER0_CH2_ON, TIMER11_CH11
PD8	55	I/O	5VT	Default: PD8 Alternate: EXMC_D13 Remap: USART2_TX
PD9	56	I/O	5VT	Default: PD9 Alternate: EXMC_D14 Remap: USART2_RX
PD10	57	I/O	5VT	Default: PD10 Alternate: EXMC_D15 Remap: USART2_CK
PD11	58	I/O	5VT	Default: PD11 Alternate: EXMC_A16 Remap: USART2_CTS
PD12	59	I/O	5VT	Default: PD12 Alternate: EXMC_A17 Remap: TIMER3_CH0, USART2_RTS
PD13	60	I/O	5VT	Default: PD13 Alternate: EXMC_A18 Remap: TIMER3_CH1
PD14	61	I/O	5VT	Default: PD14 Alternate: EXMC_D0 Remap: TIMER3_CH2
PD15	62	I/O	5VT	Default: PD15 Alternate: EXMC_D1 Remap: TIMER3_CH3, CTC_SYNC
PC6	63	I/O	5VT	Default: PC6 Alternate: I2S1_MCK, TIMER7_CH0 Remap: TIMER2_CH0

Pin Name	Pins	Pin Type ⁽¹⁾	I/O Level ⁽²⁾	Functions description
PC7	64	I/O	5VT	Default: PC7 Alternate:I2S2_MCK, TIMER7_CH1 Remap:TIMER2_CH1
PC8	65	I/O	5VT	Default: PC8 Alternate:TIMER7_CH2 Remap:TIMER2_CH2
PC9	66	I/O	5VT	Default: PC9 Alternate:TIMER7_CH3 Remap:TIMER2_CH3
PA8	67	I/O	5VT	Default: PA8 Alternate:USART0_CK, TIMER0_CH0, CK_OUT0, VCORE, USBFS_SOF, CTC_SYNC
PA9	68	I/O	5VT	Default: PA9 Alternate:USART0_TX, TIMER0_CH1, USBFS_VBUS
PA10	69	I/O	5VT	Default: PA10 Alternate:USART0_RX, TIMER0_CH2, USBFS_ID, V1REF
PA11	70	I/O	5VT	Default: PA11 Alternate:USART0_CTS, CAN0_RX, USBFS_DM, TIMER0_CH3
PA12	71	I/O	5VT	Default: PA12 Alternate:USART0_RTS, CAN0_TX, USBFS_DP, TIMER0_ETI
PA13	72	I/O	5VT	Default: JTMS, SWDIO Remap: PA13
NC	73	-	-	-
V _{SS_2}	74	P	-	Default: V _{SS_2}
V _{DD_2}	75	P	-	Default: V _{DD_2}
PA14	76	I/O	5VT	Default: JTCK, SWCLK Remap:PA14
PA15	77	I/O	5VT	Default: JTDI Alternate:SPI2_NSS, I2S2_WS Remap: TIMER1_CH0_ETI, TIMER1_ETI, PA15, SPI0_NSS
PC10	78	I/O	5VT	Default: PC10 Alternate:UART3_TX Remap:USART2_TX, SPI2_SCK, I2S2_CK
PC11	79	I/O	5VT	Default: PC11 Alternate:UART3_RX Remap:USART2_RX, SPI2_MISO
PC12	80	I/O	5VT	Default: PC12 Alternate:UART4_TX Remap:USART2_CK, SPI2_MOSI, I2S2_SD

Pin Name	Pins	Pin Type ⁽¹⁾	I/O Level ⁽²⁾	Functions description
PD0	81	I/O	5VT	Default: PD0 Alternate: EXMC_D2 Remap: OSCIN, CAN0_RX
PD1	82	I/O	5VT	Default: PD1 Alternate: EXMC_D3 Remap: OSCOUT, CAN0_TX
PD2	83	I/O	5VT	Default: PD2 Alternate: TIMER2_ETI, UART4_RX
PD3	84	I/O	5VT	Default: PD3 Alternate: EXMC_CLK Remap: USART1_CTS
PD4	85	I/O	5VT	Default: PD4 Alternate: EXMC_NOE Remap: USART1_RTS
PD5	86	I/O	5VT	Default: PD5 Alternate: EXMC_NWE Remap: USART1_TX
PD6	87	I/O	5VT	Default: PD6 Alternate: EXMC_NWAIT Remap: USART1_RX
PD7	88	I/O	5VT	Default: PD7 Alternate: EXMC_NE0 Remap: USART1_CK
PB3	89	I/O	5VT	Default: JTDO Alternate: SPI2_SCK, I2S2_CK Remap: TIMER1_CH1, PB3, TRACESWO, SPI0_SCK
PB4	90	I/O	5VT	Default: NJTRST Alternate: SPI2_MISO, I2C0_TXFRAME Remap: TIMER2_CH0, PB4, SPI0_MISO
PB5	91	I/O	-	Default: PB5 Alternate: I2C0_SMBA, SPI2_MOSI, I2S2_SD Remap: TIMER2_CH1, SPI0_MOSI, CAN1_RX
PB6	92	I/O	5VT	Default: PB6 Alternate: I2C0_SCL, TIMER3_CH0 Remap: USART0_TX, CAN1_TX, SPI0_IO2
PB7	93	I/O	5VT	Default: PB7 Alternate: I2C0_SDA, TIMER3_CH1, EXMC_NL(NADV) Remap: USART0_RX, SPI0_IO3
BOOT0	94	I	-	Default: BOOT0

Pin Name	Pins	Pin Type ⁽¹⁾	I/O Level ⁽²⁾	Functions description
PB8	95	I/O	5VT	Default: PB8 Alternate:TIMER3_CH2, TIMER9_CH0 Remap:I2C0_SCL, CAN0_RX
PB9	96	I/O	5VT	Default: PB9 Alternate:TIMER3_CH3, TIMER10_CH0 Remap:I2C0_SDA, CAN0_TX
PE0	97	I/O	5VT	Default:PE0 Alternate:TIMER3_ETI, EXMC_NBL0
PE1	98	I/O	5VT	Default: PE1 Alternate:EXMC_NBL1
V _{DD_3}	99	P	-	Default: V _{DD_3}
V _{DD_3}	100	P	-	Default: V _{DD_3}

Notes:

1. Type: I= input, O = output, P = power.
2. I/O Level: 5VT = 5V tolerant.
3. Functions are available in GD32E103xx devices.

2.6.2. GD32E103Rx LQFP64 pin definitions

Pin Name	Pins	Pin Type ⁽¹⁾	I/O Level ⁽²⁾	Functions description
V _{BAT}	1	P	-	Default: V _{BAT}
PC13-TAMPER-RTC	2	I/O	-	Default: PC13 Alternate: RTC_TAMPER
PC14-OSC32IN	3	I/O	-	Default: PC14 Alternate:OSC32IN
PC15-OSC32OUT	4	I/O	-	Default: PC15 Alternate:OSC32OUT
OSCIN	5	I	-	Default: OSCIN Remap:PD0
OSCOUT	6	O	-	Default: OSCOUT Remap:PD1
NRST	7	I/O	-	Default: NRST
PC0	8	I/O	-	Default: PC0 Alternate: ADC01_IN10
PC1	9	I/O	-	Default: PC1 Alternate: ADC01_IN11
PC2	10	I/O	-	Default: PC2 Alternate: ADC01_IN12

Pin Name	Pins	Pin Type ⁽¹⁾	I/O Level ⁽²⁾	Functions description
PC3	11	I/O	-	Default: PC3 Alternate: ADC01_IN13
V _{SSA}	12	P	-	Default: V _{SSA}
V _{REF-}	-	P	-	Default: V _{REF-}
V _{REF+}	-	P	-	Default: V _{REF+}
V _{DDA}	13	P	-	Default: V _{DDA}
PA0- WКУ P	14	I/O	-	Default: PA0 Alternate: WKUP, USART1_CTS, ADC01_IN0, TIMER1_CH0_ETI, TIMER4_CH0, TIMER7_ETI
PA1	15	I/O	-	Default: PA1 Alternate: USART1_RTS, ADC01_IN1, TIMER4_CH1, TIMER1_CH1
PA2	16	I/O	-	Default: PA2 Alternate: USART1_TX, TIMER4_CH2, ADC01_IN2, TIMER8_CH0, TIMER1_CH2, SPI0_IO2
PA3	17	I/O	-	Default: PA3 Alternate: USART1_RX, TIMER4_CH3, ADC01_IN3, TIMER1_CH3, TIMER8_CH1, SPI0_IO3
V _{SS_4}	18	P	-	Default: V _{SS_4}
V _{DD_4}	19	P	-	Default: V _{DD_4}
PA4	20	I/O	-	Default: PA4 Alternate: SPI0_NSS, USART1_CK, DAC_OUT0, ADC01_IN4 Remap:SPI2_NSS, I2S2_WS
PA5	21	I/O	-	Default: PA5 Alternate: SPI0_SCK, ADC01_IN5, DAC_OUT1
PA6	22	I/O	-	Default: PA6 Alternate: SPI0_MISO, TIMER7_BKIN, ADC01_IN6, TIMER2_CH0, TIMER12_CH0 Remap:TIMER0_BKIN
PA7	23	I/O	-	Default: PA7 Alternate: SPI0_MOSI, TIMER7_CH0_ON, ADC01_IN7, TIMER2_CH1, TIMER13_CH0 Remap:TIMER0_CH0_ON
PC4	24	I/O	-	Default: PC4 Alternate: ADC01_IN14
PC5	25	I/O	-	Default: PC5 Alternate: ADC01_IN15
PB0	26	I/O	-	Default: PB0 Alternate: ADC01_IN8, TIMER2_CH2, TIMER7_CH1_ON Remap:TIMER0_CH1_ON

Pin Name	Pins	Pin Type ⁽¹⁾	I/O Level ⁽²⁾	Functions description
PB1	27	I/O	-	Default: PB1 Alternate: ADC01_IN9, TIMER2_CH3, TIMER7_CH2_ON Remap:TIMER0_CH2_ON
PB2	28	I/O	5VT	Default: PB2, BOOT1
PB10	29	I/O	5VT	Default: PB10 Alternate:I2C1_SCL, USART2_TX Remap: TIMER1_CH2
PB11	30	I/O	5VT	Default: PB11 Alternate:I2C1_SDA, USART2_RX Remap: TIMER1_CH3
V _{SS_1}	31	P	-	Default:V _{SS_1}
V _{DD_1}	32	P	-	Default:V _{DD_1}
PB12	33	I/O	5VT	Default: PB12 Alternate:SPI1_NSS, I2S1_WS, I2C1_SMBA, USART2_CK, TIMER0_BKIN, CAN1_RX
PB13	34	I/O	5VT	Default: PB13 Alternate: SPI1_SCK, I2S1_CK, USART2_CTS, TIMER0_CH0_ON, CAN1_TX, I2C1_TXFRAME
PB14	35	I/O	5VT	Default: PB14 Alternate:SPI1_MISO, USART2_RTS, TIMER0_CH1_ON, TIMER11_CH0
PB15	36	I/O	5VT	Default: PB15 Alternate:SPI1_MOSI, I2S1_SD, TIMER0_CH2_ON, TIMER11_CH11
PC6	37	I/O	5VT	Default: PC6 Alternate:I2S1_MCK, TIMER7_CH0 Remap:TIMER2_CH0
PC7	38	I/O	5VT	Default: PC7 Alternate:I2S2_MCK, TIMER7_CH1 Remap:TIMER2_CH1
PC8	39	I/O	5VT	Default: PC8 Alternate:TIMER7_CH2 Remap:TIMER2_CH2
PC9	40	I/O	5VT	Default: PC9 Alternate:TIMER7_CH3 Remap:TIMER2_CH3
PA8	41	I/O	5VT	Default: PA8 Alternate:USART0_CK, TIMER0_CH0, CK_OUT0, VCORE, USBFS_SOF, CTC_SYNC
PA9	42	I/O	5VT	Default: PA9 Alternate:USART0_TX, TIMER0_CH1, USBFS_VBUS

Pin Name	Pins	Pin Type ⁽¹⁾	I/O Level ⁽²⁾	Functions description
PA10	43	I/O	5VT	Default: PA10 Alternate:USART0_RX, TIMER0_CH2, USBFS_ID, V1REF
PA11	44	I/O	5VT	Default: PA11 Alternate:USART0_CTS, CAN0_RX, USBFS_DM, TIMER0_CH3
PA12	45	I/O	5VT	Default: PA12 Alternate:USART0_RTS, CAN0_TX, USBFS_DP, TIMER0_ETI
PA13	46	I/O	5VT	Default: JTMS, SWDIO Remap: PA13
V _{SS_2}	47	P	-	Default: V _{SS_2}
V _{DD_2}	48	P	-	Default: V _{DD_2}
PA14	49	I/O	5VT	Default: JTCK, SWCLK Remap:PA14
PA15	50	I/O	5VT	Default: JTDI Alternate:SPI2_NSS, I2S2_WS Remap: TIMER1_CH0_ETI, TIMER1_ETI, PA15, SPI0_NSS
PC10	51	I/O	5VT	Default: PC10 Alternate:UART3_TX Remap:USART2_TX, SPI2_SCK, I2S2_CK
PC11	52	I/O	5VT	Default: PC11 Alternate:UART3_RX Remap:USART2_RX, SPI2_MISO
PC12	53	I/O	5VT	Default: PC12 Alternate:UART4_TX Remap:USART2_CK, SPI2_MOSI, I2S2_SD
PD2	54	I/O	5VT	Default: PD2 Alternate:TIMER2_ETI, UART4_RX
PB3	55	I/O	5VT	Default: JTDO Alternate:SPI2_SCK, I2S2_CK Remap:TIMER1_CH1, PB3, TRACESWO, SPI0_SCK
PB4	56	I/O	5VT	Default: NJTRST Alternate:SPI2_MISO, I2C0_TXFRAME Remap:TIMER2_CH0, PB4, SPI0_MISO
PB5	57	I/O	-	Default: PB5 Alternate:I2C0_SMBA, SPI2_MOSI, I2S2_SD Remap:TIMER2_CH1, SPI0_MOSI, CAN1_RX
PB6	58	I/O	5VT	Default: PB6 Alternate:I2C0_SCL, TIMER3_CH0 Remap:USART0_TX, CAN1_TX, SPI0_IO2
PB7	59	I/O	5VT	Default: PB7

Pin Name	Pins	Pin Type ⁽¹⁾	I/O Level ⁽²⁾	Functions description
				Alternate: I2C0_SDA, TIMER3_CH1 Remap:USART0_RX, SPI0_IO3
BOOT0	60	I	-	Default: BOOT0
PB8	61	I/O	5VT	Default: PB8 Alternate:TIMER3_CH2, TIMER9_CH0 Remap:I2C0_SCL, CAN0_RX
PB9	62	I/O	5VT	Default: PB9 Alternate:TIMER3_CH3, TIMER10_CH0 Remap:I2C0_SDA, CAN0_TX
V _{DD_3}	63	P	-	Default: V _{DD_3}
V _{DD_3}	64	P	-	Default: V _{DD_3}

Notes:

1. Type: I= input, O = output, P = power.
2. I/O Level:5VT = 5V tolerant.
3. Functions are available in GD32E103xx devices.

2.6.3. GD32E103Cx LQFP48 pin definitions

Pin Name	Pins	Pin Type ⁽¹⁾	I/O Level ⁽²⁾	Functions description
V _{BAT}	1	P	-	Default: V _{BAT}
PC13-TAMPER-RTC	2	I/O	-	Default: PC13 Alternate: RTC_TAMPER
PC14-OSC32IN	3	I/O	-	Default: PC14 Alternate:OSC32IN
PC15-OSC32OUT	4	I/O	-	Default: PC15 Alternate:OSC32OUT
OSCIN	5	I	-	Default: OSCIN Remap:PD0
OSCOUT	6	O	-	Default: OSCOUT Remap:PD1
NRST	7	I/O	-	Default: NRST
V _{SSA}	8	P	-	Default: V _{SSA}
V _{DDA}	9	P	-	Default: V _{DDA}
PA0-WKUP	10	I/O	-	Default: PA0 Alternate: WKUP, USART1_CTS, ADC01_IN0, TIMER1_CH0_ETI, TIMER4_CH0, TIMER7_ETI
PA1	11	I/O	-	Default: PA1 Alternate: USART1_RTS, ADC01_IN1, TIMER4_CH1, TIMER1_CH1

Pin Name	Pins	Pin Type ⁽¹⁾	I/O Level ⁽²⁾	Functions description
PA2	12	I/O	-	Default: PA2 Alternate: USART1_TX, TIMER4_CH2, ADC01_IN2, TIMER8_CH0, TIMER1_CH2, SPI0_IO2
PA3	13	I/O	-	Default: PA3 Alternate: USART1_RX, TIMER4_CH3, ADC01_IN3, TIMER1_CH3, TIMER8_CH1, SPI0_IO3
PA4	14	I/O	-	Default: PA4 Alternate: SPI0_NSS, USART1_CK, DAC_OUT0, ADC01_IN4 Remap:SPI2_NSS, I2S2_WS
PA5	15	I/O	-	Default: PA5 Alternate: SPI0_SCK, ADC01_IN5, DAC_OUT1
PA6	16	I/O	-	Default: PA6 Alternate: SPI0_MISO, TIMER7_BKIN, ADC01_IN6, TIMER2_CH0, TIMER12_CH0 Remap:TIMER0_BKIN
PA7	17	I/O	-	Default: PA7 Alternate: SPI0_MOSI, TIMER7_CH0_ON, ADC01_IN7, TIMER2_CH1, TIMER13_CH0 Remap:TIMER0_CH0_ON
PB0	18	I/O	-	Default: PB0 Alternate: ADC01_IN8, TIMER2_CH2, TIMER7_CH1_ON Remap:TIMER0_CH1_ON
PB1	19	I/O	-	Default: PB1 Alternate: ADC01_IN9, TIMER2_CH3, TIMER7_CH2_ON Remap:TIMER0_CH2_ON
PB2	20	I/O	5VT	Default: PB2, BOOT1
PB10	21	I/O	5VT	Default: PB10 Alternate:I2C1_SCL, USART2_TX Remap: TIMER1_CH2
PB11	22	I/O	5VT	Default: PB11 Alternate:I2C1_SDA, USART2_RX Remap: TIMER1_CH3
V _{SS_1}	23	P	-	Default:V _{SS_1}
V _{DD_1}	24	P	-	Default:V _{DD_1}
PB12	25	I/O	5VT	Default: PB12 Alternate:SPI1_NSS, I2S1_WS, I2C1_SMBA, USART2_CK, TIMER0_BKIN, CAN1_RX
PB13	26	I/O	5VT	Default: PB13 Alternate: SPI1_SCK, I2S1_CK, USART2_CTS, TIMER0_CH0_ON, CAN1_TX, I2C1_TXFRAME

Pin Name	Pins	Pin Type ⁽¹⁾	I/O Level ⁽²⁾	Functions description
PB14	27	I/O	5VT	Default: PB14 Alternate: SPI1_MISO, USART2_RTS, TIMER0_CH1_ON, TIMER11_CH0
PB15	28	I/O	5VT	Default: PB15 Alternate: SPI1_MOSI, I2S1_SD, TIMER0_CH2_ON, TIMER11_CH11
PA8	29	I/O	5VT	Default: PA8 Alternate: USART0_CK, TIMER0_CH0, CK_OUT0, VCORE, USBFS_SOF, CTC_SYNC
PA9	30	I/O	5VT	Default: PA9 Alternate: USART0_TX, TIMER0_CH1, USBFS_VBUS
PA10	31	I/O	5VT	Default: PA10 Alternate: USART0_RX, TIMER0_CH2, USBFS_ID, V1REF
PA11	32	I/O	5VT	Default: PA11 Alternate: USART0_CTS, CAN0_RX, USBFS_DM, TIMER0_CH3
PA12	33	I/O	5VT	Default: PA12 Alternate: USART0_RTS, CAN0_TX, USBFS_DP, TIMER0_ETI
PA13	34	I/O	5VT	Default: JTMS, SWDIO Remap: PA13
V _{SS_2}	35	P	-	Default: V _{SS_2}
V _{DD_2}	36	P	-	Default: V _{DD_2}
PA14	37	I/O	5VT	Default: JTCK, SWCLK Remap: PA14
PA15	38	I/O	5VT	Default: JTDI Alternate: SPI2_NSS, I2S2_WS Remap: TIMER1_CH0_ETI, TIMER1_ETI, PA15, SPI0_NSS
PB3	39	I/O	5VT	Default: JTDO Alternate: SPI2_SCK, I2S2_CK Remap: TIMER1_CH1, PB3, TRACESWO, SPI0_SCK
PB4	40	I/O	5VT	Default: NJTRST Alternate: SPI2_MISO, I2C0_TXFRAME Remap: TIMER2_CH0, PB4, SPI0_MISO
PB5	41	I/O	-	Default: PB5 Alternate: I2C0_SMBA, SPI2_MOSI, I2S2_SD Remap: TIMER2_CH1, SPI0_MOSI, CAN1_RX
PB6	42	I/O	5VT	Default: PB6 Alternate: I2C0_SCL, TIMER3_CH0

Pin Name	Pins	Pin Type ⁽¹⁾	I/O Level ⁽²⁾	Functions description
				Remap:USART0_TX, CAN1_TX, SPI0_IO2
PB7	43	I/O	5VT	Default: PB7 Alternate: I2C0_SDA, TIMER3_CH1 Remap:USART0_RX, SPI0_IO3
BOOT0	44	I	-	Default: BOOT0
PB8	45	I/O	5VT	Default: PB8 Alternate:TIMER3_CH2, TIMER9_CH0 Remap:I2C0_SCL, CAN0_RX
PB9	46	I/O	5VT	Default: PB9 Alternate:TIMER3_CH3, TIMER10_CH0 Remap:I2C0_SDA, CAN0_TX
V _{DD_3}	47	P	-	Default: V _{DD_3}
V _{DD_3}	48	P	-	Default: V _{DD_3}

Notes:

1. Type: I= input, O = output, P = power.
2. I/O Level:5VT = 5V tolerant.
3. Functions are available in GD32E103xx devices.

2.6.4. GD32E103Tx QFN36 pin definitions

Pin Name	Pins	Pin Type ⁽¹⁾	I/O Level ⁽²⁾	Functions description
OSCIN	2	I	-	Default: OSCIN Remap:PD0
OSCOU	3	O	-	Default: OSCOUT Remap:PD1
NRST	4	I/O	-	Default: NRST
V _{SSA}	5	P	-	Default: V _{SSA}
V _{DDA}	6	P	-	Default: V _{DDA}
PA0-WKUP	7	I/O	-	Default: PA0 Alternate: WKUP, USART1_CTS, ADC01_IN0, TIMER1_CH0_ETI, TIMER4_CH0, TIMER7_ETI
PA1	8	I/O	-	Default: PA1 Alternate: USART1_RTS, ADC01_IN1, TIMER4_CH1, TIMER1_CH1
PA2	9	I/O	-	Default: PA2 Alternate: USART1_TX, TIMER4_CH2, ADC01_IN2, TIMER8_CH0, TIMER1_CH2, SPI0_IO2
PA3	10	I/O	-	Default: PA3 Alternate: USART1_RX, TIMER4_CH3,

Pin Name	Pins	Pin Type ⁽¹⁾	I/O Level ⁽²⁾	Functions description
				ADC01_IN3, TIMER1_CH3, TIMER8_CH1, SPI0_IO3
PA4	11	I/O	-	Default: PA4 Alternate: SPI0_NSS, USART1_CK, DAC_OUT0, ADC01_IN4
PA5	12	I/O	-	Default: PA5 Alternate: SPI0_SCK, ADC01_IN5, DAC_OUT1
PA6	13	I/O	-	Default: PA6 Alternate: SPI0_MISO, TIMER7_BKIN, ADC01_IN6, TIMER2_CH0, TIMER12_CH0 Remap:TIMER0_BKIN
PA7	14	I/O	-	Default: PA7 Alternate: SPI0_MOSI, TIMER7_CH0_ON, ADC01_IN7, TIMER2_CH1, TIMER13_CH0 Remap:TIMER0_CH0_ON
PB0	15	I/O	-	Default: PB0 Alternate: ADC01_IN8, TIMER2_CH2, TIMER7_CH1_ON Remap:TIMER0_CH1_ON
PB1	16	I/O	-	Default: PB1 Alternate: ADC01_IN9, TIMER2_CH3, TIMER7_CH2_ON Remap:TIMER0_CH2_ON
PB2	17	I/O	5VT	Default: PB2, BOOT1
V _{SS_1}	18	P	-	Default:V _{SS_1}
V _{DD_1}	19	P	-	Default:V _{DD_1}
PA8	20	I/O	5VT	Default: PA8 Alternate:USART0_CK, TIMER0_CH0, CK_OUT0, VCORE, USBFS_SOF, CTC_SYNC
PA9	21	I/O	5VT	Default: PA9 Alternate:USART0_TX, TIMER0_CH1, USBFS_VBUS
PA10	22	I/O	5VT	Default: PA10 Alternate:USART0_RX, TIMER0_CH2, USBFS_ID, V1REF
PA11	23	I/O	5VT	Default: PA11 Alternate:USART0_CTS, CAN0_RX, USBFS_DM, TIMER0_CH3
PA12	24	I/O	5VT	Default: PA12 Alternate:USART0_RTS, CAN0_TX, USBFS_DP, TIMER0_ETI

Pin Name	Pins	Pin Type ⁽¹⁾	I/O Level ⁽²⁾	Functions description
PA13	25	I/O	5VT	Default: JTMS, SWDIO Remap: PA13
V _{SS_2}	26	P	-	Default: V _{SS_2}
V _{DD_2}	27	P	-	Default: V _{DD_2}
PA14	28	I/O	5VT	Default: JTCK, SWCLK Remap:PA14
PA15	29	I/O	5VT	Default: JTDI Remap: TIMER1_CH0_ETI, TIMER1_ETI, PA15, SPI0_NSS
PB3	30	I/O	5VT	Default: JTDO Remap:TIMER1_CH1, PB3, TRACESWO, SPI0_SCK
PB4	31	I/O	5VT	Default: NJTRST Alternate:I2C0_TXFRAME Remap:TIMER2_CH0, PB4, SPI0_MISO
PB5	32	I/O	-	Default: PB5 Alternate:I2C0_SMBA Remap:TIMER2_CH1, SPI0_MOSI, CAN1_RX
PB6	33	I/O	5VT	Default: PB6 Alternate:I2C0_SCL, TIMER3_CH0 Remap:USART0_TX, CAN1_TX, SPI0_IO2
PB7	34	I/O	5VT	Default: PB7 Alternate: I2C0_SDA, TIMER3_CH1 Remap:USART0_RX, SPI0_IO3
BOOT0	35	I	-	Default: BOOT0
V _{DD_3}	36	P	-	Default: V _{DD_3}
V _{DD_3}	1	P	-	Default: V _{DD_3}

Notes:

1. Type: I= input, O = output, P = power.
2. I/O Level: 5VT = 5V tolerant.
3. Functions are available in GD32E103xx devices.

3. Functional description

3.1. ARM® Cortex®-M4 core

The ARM® Cortex®-M4 processor is a high performance embedded processor with DSP instructions which allow efficient signal processing and complex algorithm execution. It brings an efficient, easy-to-use blend of control and signal processing capabilities to meet the digital signal control markets demand. The processor is highly configurable enabling a wide range of implementations from those requiring floating point operations, memory protection and powerful trace technology to cost sensitive devices requiring minimal area, while delivering outstanding computational performance and an advanced system response to interrupts.

32-bit ARM® Cortex®-M4 processor core

- Up to 120 MHz operation frequency
- Single-cycle multiplication and hardware divider
- Floating Point Unit (FPU)
- Integrated DSP instructions
- Integrated Nested Vectored Interrupt Controller (NVIC)
- 24-bit SysTick timer

The Cortex®-M4 processor is based on the ARMv7-M architecture and supports both Thumb and Thumb-2 instruction sets. Some system peripherals listed below are also provided by Cortex®-M4:

- Internal Bus Matrix connected with ICode bus, DCode bus, system bus, Private Peripheral Bus (PPB) and debug accesses (AHB-AP)
- Nested Vectored Interrupt Controller (NVIC)
- Flash Patch and Breakpoint (FPB)
- Data Watchpoint and Trace (DWT)
- Instrument Trace Macrocell (ITM)
- Serial Wire JTAG Debug Port (SWJ-DP)
- Trace Port Interface Unit (TPIU)

3.2. On-chip memory

- Up to 128 Kbytes of Flash memory
- Up to 32 KB of SRAM

The ARM® Cortex®-M4 processor is structured in Harvard architecture which can use separate buses to fetch instructions and load/store data. 128 Kbytes of inner Flash at most, which includes code Flash that available for storing programs and data, and accessed (R/W) at CPU clock speed with zero wait states. An extra data Flash is also included for storing data mainly. [Table 2-2. GD32E103xx memory map](#) shows the memory of the GD32E103xx series of devices, including Flash, SRAM, peripheral, and other pre-defined regions.

3.3. Clock, reset and supply management

- Internal 8 MHz factory-trimmed RC and external 4 to 32 MHz crystal oscillator
- Internal 48 MHz RC oscillator
- Internal 40 KHz RC calibrated oscillator and external 32.768 KHz crystal oscillator
- 1.8 to 3.6 V application supply and I/Os
- Supply Supervisor: POR (Power On Reset), PDR (Power Down Reset), and low voltage detector (LVD)

The Clock Control Unit (CCU) provides a range of oscillator and clock functions. These include internal RC oscillator and external crystal oscillator, high speed and low speed two types. Several prescalers allow the frequency configuration of the AHB and two APB domains. The maximum frequency of the two AHB domains are 120 MHz. The maximum frequency of the two APB domains including APB1 is 60 MHz and APB2 is 120 MHz. See [Figure 2-6. GD32E103xx clock tree](#) for details on the clock tree.

The Reset Control Unit (RCU) controls three kinds of reset: system reset resets the processor core and peripheral IP components. Power-on reset (POR) and power-down reset (PDR) are always active, and ensures proper operation starting from/down to 2.6 V. The device remains in reset mode when V_{DD} is below a specified threshold. The embedded low voltage detector (LVD) monitors the power supply, compares it to the voltage threshold and generates an interrupt as a warning message for leading the MCU into security.

Power supply schemes:

- V_{DD} range: 1.8 to 3.6 V, external power supply for I/Os and the internal regulator. Provided externally through V_{DD} pins.
- V_{SSA} , V_{DDA} range: 1.8 to 3.6 V, external analog power supplies for ADC, reset blocks, RCs and PLL. V_{DDA} and V_{SSA} must be connected to V_{DD} and V_{SS} , respectively.
- V_{BAT} range: 1.8 to 3.6 V, power supply for RTC, external clock 32.768 KHz oscillator and backup registers (through power switch) when V_{DD} is not present.

3.4. Boot modes

At startup, boot pins are used to select one of three boot options:

- Boot from main flash memory (default)
- Boot from system memory
- Boot from on-chip SRAM

In default condition, boot from main Flash memory is selected. The boot loader is located in the internal boot ROM memory (system memory). It is used to reprogram the Flash memory by using USART0 (PA9 and PA10).

3.5. Power saving modes

The MCU supports three kinds of power saving modes to achieve even lower power consumption. They are sleep mode, deep-sleep mode, and standby mode. These operating modes reduce the power consumption and allow the application to achieve the best balance between the CPU operating time, speed and power consumption.

- **Sleep mode**

In sleep mode, only the clock of CPU core is off. All peripherals continue to operate and any interrupt/event can wake up the system.

- **Deep-sleep mode**

In deep-sleep mode, all clocks in the 1.2V domain are off, and all of the high speed crystal oscillator (IRC8M, HXTAL) and PLL are disabled. Only the contents of SRAM and registers are retained. Any interrupt or wakeup event from EXTI lines can wake up the system from the deep-sleep mode including the 16 external lines, the RTC alarm, the LVD output, and USB wakeup. When exiting the deep-sleep mode, the IRC8M is selected as the system clock.

- **Standby mode**

In standby mode, the whole 1.2V domain is power off, the LDO is shut down, and all of IRC8M, HXTAL and PLL are disabled. The contents of SRAM and registers (except Backup Registers) are lost. There are four wakeup sources for the standby mode, including the external reset from NRST pin, the RTC, the FWDG reset, and the rising edge on WKUP pin.

3.6. Analog to digital converter (ADC)

- 12-bit SAR ADC's conversion rate is up to 3 MSPS
- 12-bit, 10-bit, 8-bit or 6-bit configurable resolution
- Hardware oversampling ratio adjustable from 2 to 256x improves resolution to 16-bit
- Input voltage range: V_{REF-} to V_{REF+} (2.4 to 3.6 V)
- Temperature sensor

Up to two 12-bit 3 MSPS multi-channel ADCs are integrated in the device. It has a total of 18 multiplexed channels: 16 external channels, 1 channel for internal temperature sensor (V_{SENSE}), 1 channel for internal reference voltage (V_{REFINT}). The input voltage range is from V_{REF-} to V_{REF+} . An on-chip hardware oversampling scheme improves performance while off-loading the related computational burden from the CPU. An analog watchdog block can be used to detect the channels, which are required to remain within a specific threshold window. A configurable channel management block can be used to perform conversions in single, continuous, scan or discontinuous mode to support more advanced use.

The ADC can be triggered from the events generated by the general level 0 timers (TIMERx) and the advanced timers (TIMER0 and TIMER7) with internal connection. The temperature sensor can be used to generate a voltage that varies linearly with temperature. It is internally

connected to the ADC_IN16 input channel which is used to convert the sensor output voltage in a digital value.

3.7. Digital to analog converter (DAC)

- 12-bit DAC with independent output channels
- 8-bit or 12-bit mode in conjunction with the DMA controller

The 12-bit buffered DAC is used to generate variable analog outputs. The DAC channels can be triggered by the timer or EXTI with DMA support. In dual DAC channel operation, conversions could be done independently or simultaneously. The maximum output value of the DAC is V_{REF+} .

3.8. DMA

- 7 channel DMA0 controller and 5 channel DMA1 controller
- Peripherals supported: Timers, ADC, SPIs, I2Cs, USARTs, DAC, I2S

The flexible general-purpose DMA controllers provide a hardware method of transferring data between peripherals and/or memory without intervention from the CPU, thereby freeing up bandwidth for other system functions. Three types of access method are supported: peripheral to memory, memory to peripheral, memory to memory.

Each channel is connected to fixed hardware DMA requests. The priorities of DMA channel requests are determined by software configuration and hardware channel number. Transfer size of source and destination are independent and configurable.

3.9. General-purpose inputs/outputs (GPIOs)

- Up to 80 fast GPIOs, all mappable on 16 external interrupt lines
- Analog input/output configurable
- Alternate function input/output configurable

There are up to 80 general purpose I/O pins (GPIO) in GD32E103xx, named PA0 ~ PA15, PB0 ~ PB15, PC0 ~ PC15, PD0 ~ PD15 and PE0 ~ PE15 to implement logic input/output functions. Each of the GPIO ports has related control and configuration registers to satisfy the requirements of specific applications. The external interrupts on the GPIO pins of the device have related control and configuration registers in the Interrupt/event controller (EXTI). The GPIO ports are pin-shared with other alternative functions (AFs) to obtain maximum flexibility on the package pins. Each of the GPIO pins can be configured by software as output (push-pull or open-drain), as input (with or without pull-up or pull-down) or as peripheral alternate function. Most of the GPIO pins are shared with digital or analog alternate functions. All GPIOs are high-current capable except for analog inputs.

3.10. Timers and PWM generation

- Two 16-bit advanced timer (TIMER0 & TIMER7), ten 16-bit general timers (TIMER1 ~ TIMER4, TIMER8 ~ TIMER13), and two 16-bit basic timer (TIMER5 & TIMER6)
- Up to 4 independent channels of PWM, output compare or input capture for each general timer and external trigger input
- 16-bit, motor control PWM advanced timer with programmable dead-time generation for output match
- Encoder interface controller with two inputs using quadrature decoder
- 24-bit SysTick timer down counter
- 2 watchdog timers (free watchdog timer and window watchdog timer)

The advanced timer (TIMER0 & TIMER7) can be used as a three-phase PWM multiplexed on 6 channels. It has complementary PWM outputs with programmable dead-time generation. It can also be used as a complete general timer. The 4 independent channels can be used for input capture, output compare, PWM generation (edge-aligned or center-aligned counting modes) and single pulse mode output. If configured as a general 16-bit timer, it has the same functions as the TIMERx timer. It can be synchronized with external signals or to interconnect with other general timers together which have the same architecture and features.

The general timer, can be used for a variety of purposes including general time, input signal pulse width measurement or output waveform generation such as a single pulse generation or PWM output, up to 4 independent channels for input capture/output compare. TIMER1 ~ TIMER4 is based on a 16-bit auto-reload up/downcounter and a 16-bit prescaler. TIMER8 ~ TIMER13 is based on a 16-bit auto-reload upcounter and a 16-bit prescaler. The general timer also supports an encoder interface with two inputs using quadrature decoder.

The basic timer, known as TIMER5 & TIMER6, are mainly used for DAC trigger generation. They can also be used as a simple 16-bit time base.

The GD32E103xx have two watchdog peripherals, free watchdog timer and window watchdog timer. They offer a combination of high safety level, flexibility of use and timing accuracy.

The free watchdog timer includes a 12-bit down-counting counter and an 8-bit prescaler. It is clocked from an independent 40 KHz internal RC and as it operates independently of the main clock, it can operate in deep-sleep and standby modes. It can be used either as a watchdog to reset the device when a problem occurs, or as a free-running timer for application timeout management.

The window watchdog timer is based on a 7-bit down counter that can be set as free-running. It can be used as a watchdog to reset the device when a problem occurs. It is clocked from the main clock. It has an early wakeup interrupt capability and the counter can be frozen in debug mode.

The SysTick timer is dedicated for OS, but could also be used as a standard down counter. It features:

- A 24-bit down counter
- Auto reload capability
- Maskable system interrupt generation when the counter reaches 0
- Programmable clock source

3.11. Real time clock (RTC)

- 32-bit up-counter with a programmable 20-bit prescaler
- Alarm function
- Interrupt and wake-up event

The real time clock is an independent timer which provides a set of continuously running counters which can be used with suitable software to provide a clock calendar function, and provides an alarm interrupt and an expected interrupt. The RTC features a 32-bit programmable counter for long-term measurement using the compare register to generate an alarm. A 20-bit prescaler is used for the time base clock and is by default configured to generate a time base of 1 second from a clock at 32.768 KHz from external crystal oscillator.

3.12. Inter-integrated circuit (I2C)

- Up to two I2C bus interfaces can support both master and slave mode with a frequency up to 1 MHz (Fast mode plus)
- Provide arbitration function, optional PEC (packet error checking) generation and checking
- Supports 7-bit and 10-bit addressing mode and general call addressing mode

The I2C interface is an internal circuit allowing communication with an external I2C interface which is an industry standard two line serial interface used for connection to external hardware. These two serial lines are known as a serial data line (SDA) and a serial clock line (SCL). The I2C module provides several data transfer rates: up to 100 KHz of standard mode, up to 400 KHz of the fast mode and up to 1 MHz of the fast mode plus. The I2C module also has an arbitration detect function to prevent the situation where more than one master attempts to transmit data to the I2C bus at the same time. A CRC-8 calculator is also provided in I2C interface to perform packet error checking for I2C data.

3.13. Serial peripheral interface (SPI)

- Up to three SPI interfaces with a frequency of up to 30 MHz
- Support both master and slave mode
- Hardware CRC calculation and transmit automatic CRC error checking
- Quad-SPI configuration available in master mode (only in SPI1)
- SPI TI mode and NSS pulse mode supported

The SPI interface uses 4 pins, among which are the serial data input and output lines (MISO & MOSI), the clock line (SCK) and the slave select line (NSS). Both SPIs can be served by the DMA controller. The SPI interface may be used for a variety of purposes, including simplex synchronous transfers on two lines with a possible bidirectional data line or reliable communication using CRC checking.

3.14. Universal synchronous asynchronous receiver transmitter (USART)

- Up to three USARTs and two UARTs with operating frequency up to 7.5MHz
- Supports both asynchronous and clocked synchronous serial communication modes
- IrDA SIR encoder and decoder support
- LIN break generation and detection
- USARTs support ISO 7816-3 compliant smart card interface

The USART (USART0, USART1 and USART2) and UART (UART3 & UART4) are used to translate data between parallel and serial interfaces, provides a flexible full duplex data exchange using synchronous or asynchronous transfer. It is also commonly used for RS-232 standard communication. The USART/UART includes a programmable baud rate generator which is capable of dividing the system clock to produce a dedicated clock for the USART transmitter and receiver. The USART/UART also supports DMA function for high speed data communication except UART4.

3.15. Inter-IC sound (I2S)

- Two I2S bus interfaces with sampling frequency from 8 KHz to 192 KHz
- Support either master or slave mode

The Inter-IC sound (I2S) bus provides a standard communication interface for digital audio applications by 3-wire serial lines. GD32E103xx contain two I2S-bus interfaces that can be operated with 16/32 bit resolution in master or slave mode, pin multiplexed with SPI1 and SPI2. The audio sampling frequency from 8 KHz to 192 KHz is supported.

3.16. Universal serial bus full-speed interface (USBFS)

- One full-speed USB Interface with frequency up to 12 Mbit/s
- Internal 48 MHz oscillator support crystal-less operation
- Internal main PLL for USB CLK compliantly

The Universal Serial Bus (USB) is a 4-wire bus with 4 bidirectional endpoints. The device controller enables 12 Mbit/s data exchange with integrated transceivers. Transaction formatting is performed by the hardware, including CRC generation and checking. It supports

device modes. Transaction formatting is performed by the hardware, including CRC generation and checking. The status of a completed USB transfer or error condition is indicated by status registers. An interrupt is also generated if enabled. The required precise 48 MHz clock which can be generated from the internal main PLL (the clock source must use an HXTAL crystal oscillator) or by the internal 48 MHz oscillator in automatic trimming mode that allows crystal-less operation.

3.17. Controller area network (CAN)

- Two CAN interface supports the CAN protocols version 2.0A, 2.0B, ISO11891-1:2015 and BOSCH CAN FD specification with communication frequency up to 1 Mbit/s of classic frames and 6 Mbit/s of FD frames
- Internal main PLL for CAN CLK compliantly

Controller area network (CAN) is a method for enabling serial communication in field bus. The CAN protocol has been used extensively in industrial automation and automotive applications. It can receive and transmit standard frames with 11-bit identifiers as well as extended frames with 29-bit identifiers. Each CAN has three mailboxes for transmission and two FIFOs of three message deep for reception. It also provides 28 scalable/configurable identifier filter banks for selecting the incoming messages needed and discarding the others.

3.18. External memory controller (EXMC)

- Supported external memory: SRAM, PSRAM, ROM and NOR-Flash
- Up to 16-bit data bus
- Support to interface with Motorola 6800 and Intel 8080 type LCD directly

External memory controller (EXMC) is an abbreviation of external memory controller. It is divided in to several sub-banks for external device support, each sub-bank has its own chip selection signal but at one time, only one bank can be accessed. The EXMC support code execution from external memory. The EXMC also can be configured to interface with the most common LCD module of Motorola 6800 and Intel 8080 series and reduce the system cost and complexity.

3.19. Debug mode

- Serial wire JTAG debug port (SWJ-DP)

The ARM®SWJ-DP Interface is embedded and is a combined JTAG and serial wire debug port that enables either a serial wire debug or a JTAG probe to be connected to the target.

3.20. Package and operation temperature

- LQFP100 (GD32E103Vx), LQFP64 (GD32E103Rx) and LQFP48 (GD32E103Cx) QFN36 (GD32E103Tx)
- Operation temperature range: -40°C to +85°C (industrial level)

4. Electrical characteristics

4.1. Absolute maximum ratings

The maximum ratings are the limits to which the device can be subjected without permanently damaging the device. Note that the device is not guaranteed to operate properly at the maximum ratings. Exposure to the absolute maximum rating conditions for extended periods may affect device reliability.

Table 4-1. Absolute maximum ratings

Symbol	Parameter	Min	Max	Unit
V_{DD}	External voltage range	$V_{SS} - 0.3$	$V_{SS} + 3.6$	V
V_{DDA}	External analog supply voltage	$V_{SSA} - 0.3$	$V_{SSA} + 3.6$	V
V_{BAT}	External battery supply voltage	$V_{SS} - 0.3$	$V_{SS} + 3.6$	V
V_{IN}	Input voltage on 5V tolerant pin	$V_{SS} - 0.3$	$V_{DD} + 4.0$	V
	Input voltage on other I/O	$V_{SS} - 0.3$	4.0	V
I_{IO}	Maximum current for GPIO pins	—	25	mA
I_{INJ}	Injected current on 5V tolerant pin	—	± 5	mA
	Injected current on other I/O	—	± 5	mA
ΣI_{INJ}	Injected current on all I/O	—	± 25	mA
T_A	Operating temperature range	-40	+85	°C
T_{STG}	Storage temperature range	-55	+150	°C
T_J	Maximum junction temperature	—	125	°C

4.2. Recommended DC characteristics

Table 4-2. DC operating conditions

Symbol	Parameter	Conditions	Min	Typ	Max	Unit
V_{DD}	Supply voltage	—	1.71	3.3	3.6	V
V_{DDA}	Analog supply voltage ADC not used	—	1.71	3.3	3.6	V
	Analog supply voltage ADC used		2.4	3.3	3.6	
V_{BAT}	Battery supply voltage	—	1.71	-	3.6	V

4.3. Power consumption

The power measurements specified in the tables represent that code with data executing from on-chip Flash with the following specifications.

Table 4-3. Power consumption characteristics

Symbol	Parameter	Conditions	Min	Typ	Max	Unit
I _{DD}	Supply current (Run mode)	V _{DD} =V _{DDA} =3.3V, HXTAL=25MHz, System clock=120 MHz, All peripherals enabled	—	28.6	—	mA
		V _{DD} =V _{DDA} =3.3V, HXTAL=25MHz, System clock =120 MHz, All peripherals disabled	—	14.9	—	mA
		V _{DD} =V _{DDA} =3.3V, HXTAL=25MHz, System clock=108 MHz, All peripherals enabled	—	24.5	—	mA
		V _{DD} =V _{DDA} =3.3V, HXTAL=25MHz, System clock =108 MHz, All peripherals disabled	—	13.0	—	mA
		V _{DD} =V _{DDA} =3.3V, HXTAL=4MHz, System clock =4MHz, All peripherals enabled	—	1.6	—	mA
		V _{DD} =V _{DDA} =3.3V, HXTAL=4MHz, System clock =4MHz, All peripherals disabled	—	1.2	—	mA
		V _{DD} =V _{DDA} =3.3V, HXTAL=2MHz, System clock =2MHz, All peripherals enabled	—	1.2	—	mA
		V _{DD} =V _{DDA} =3.3V, HXTAL=2MHz, System Clock =2 MHz, All peripherals disabled	—	1.0	—	mA
	Supply current (Sleep mode)	V _{DD} =V _{DDA} =3.3V, HXTAL=25MHz, System Clock =120 MHz, CPU clock off, All peripherals enabled	—	20.8	—	mA
		V _{DD} =V _{DDA} =3.3V, HXTAL=25MHz, System Clock =120 MHz, CPU clock off, All peripherals disabled	—	7.0	—	mA
		V _{DD} =V _{DDA} =3.3V, HXTAL=25MHz, System Clock =108 MHz, CPU clock off, All peripherals enabled	—	18.7	—	mA
		V _{DD} =V _{DDA} =3.3V, HXTAL=25MHz, System Clock =108 MHz, CPU clock off, All peripherals disabled	—	6.5	—	mA
		V _{DD} =V _{DDA} =3.3V, HXTAL=4MHz, System Clock =4 MHz, CPU clock off, All peripherals enabled	—	1.4	—	mA
		V _{DD} =V _{DDA} =3.3V, HXTAL=4MHz, System Clock =4 MHz, CPU clock off, All peripherals disabled	—	0.9	—	mA
		V _{DD} =V _{DDA} =3.3V, HXTAL=2MHz, System Clock =2 MHz, CPU clock off, All peripherals enabled	—	1.1	—	mA
		V _{DD} =V _{DDA} =3.3V, HXTAL=2MHz, System Clock =2 MHz, CPU clock off, All peripherals disabled	—	0.9	—	mA
	Supply current (Deep-Sleep mode)	V _{DD} =V _{DDA} =3.3V, Regulator in run mode, All GPIOs analog mode	—	60		uA
		V _{DD} =V _{DDA} =3.3V, Regulator in low power mode, All GPIOs analog mode		48		uA

Symbol	Parameter	Conditions	Min	Typ	Max	Unit
	Supply current (Standby mode)	$V_{DD}=V_{DDA}=3.3V$, LDO off, IRC40K on, RTC on	—	2.2	—	μA
		$V_{DD}=V_{DDA}=3.3V$, LDO off, IRC40K on, RTC off	—	2.0	—	μA
		$V_{DD}=V_{DDA}=3.3V$, LDO off, IRC40K off, RTC off	—	1.5	—	μA
I_{BAT}	Battery supply current (Backup mode)	V_{DD} not available, $V_{BAT}=3.3V$, LDO off, LXTAL High drv, RTC on	—	1.5	—	μA
		V_{DD} not available, $V_{BAT}=3.3V$, LDO off, LXTAL Low drv, RTC on	—	0.8	—	μA

4.4. EMC characteristics

EMS (electromagnetic susceptibility) includes ESD (Electrostatic discharge, positive and negative) and FTB (Burst of Fast Transient voltage, positive and negative) testing result is given in the [Table 4-4. EMS characteristics](#), based on the EMS levels and classes compliant with IEC 61000 series standard.

Table 4-4. EMS characteristics

Symbol	Parameter	Conditions	Level/Class
V_{ESD}	Voltage applied to all device pins to induce a functional disturbance	$V_{DD} = 3.3 V$, $T_A = +25\text{ }^\circ C$ conforms to IEC 61000-4-2	3B
V_{FTB}	Fast transient voltage burst applied to induce a functional disturbance through 100 pF on V_{DD} and V_{SS} pins	$V_{DD} = 3.3 V$, $T_A = +25\text{ }^\circ C$ conforms to IEC 61000-4-4	4A

EMI (Electromagnetic Interference) emission testing result is given in the [Table 4-5. EMI characteristics](#), compliant with IEC 61967-2 standard which specifies the test board and the pin loading.

Table 4-5. EMI characteristics

Symbol	Parameter	Conditions	Tested frequency band	Conditions			Unit
				56M	72M	108M	
S_{EMI}	Peak level	$V_{DD} = 3.3 V$, $T_A = +25\text{ }^\circ C$, compliant with IEC 61967-2	0.1 to 2 MHz	<0	<0	<0	dB μV
			2 to 30 MHz	-3.7	-2.8	-1.6	
			30 to 130 MHz	-6.5	-8	-5.5	
			130 MHz to 1GHz	-7	-7	-5	

4.5. Power supply supervisor characteristics

Table 4-6. Power supply supervisor characteristics

Symbol	Parameter	Conditions	Min	Typ	Max	Unit
V _{LVD}	Low voltage Detector level selection	LVDT<2:0>=000(rising edge)	—	2.07	—	V
		LVDT<2:0>=000(falling edge)	—	1.97	—	
		LVDT<2:0>=001(rising edge)	—	2.2	—	
		LVDT<2:0>=001(falling edge)	—	2.1	—	
		LVDT<2:0>=010(rising edge)	—	2.34	—	
		LVDT<2:0>=010(falling edge)	—	2.24	—	
		LVDT<2:0>=011(rising edge)	—	2.47	—	
		LVDT<2:0>=011(falling edge)	—	2.37	—	
		LVDT<2:0>=100(rising edge)	—	2.61	—	
		LVDT<2:0>=100(falling edge)	—	2.51	—	
		LVDT<2:0>=101(rising edge)	—	2.74	—	
		LVDT<2:0>=101(falling edge)	—	2.64	—	
		LVDT<2:0>=110(rising edge)	—	2.88	—	
		LVDT<2:0>=110(falling edge)	—	2.78	—	
LVDT<2:0>=111(rising edge)	—	3.01	—			
LVDT<2:0>=111(falling edge)	—	2.91	—			
V _{LVDhyst}	LVD hysteresis	—	—	100	—	mV
V _{POR}	Power on reset threshold	—	—	1.66	—	V
V _{PDR}	Power down reset threshold		—	1.62	—	V
V _{HYST}	PDR hysteresis		—	0.04	—	V

Symbol	Parameter	Conditions	Min	Typ	Max	Unit
TRSTTEMP	Reset temporization		—	2.5	—	ms

4.6. Electrical sensitivity

The device is strained in order to determine its performance in terms of electrical sensitivity. Electrostatic discharges (ESD) are applied directly to the pins of the sample. Static latch-up (LU) test is based on the two measurement methods.

Table 4-7. ESD characteristics

Symbol	Parameter	Conditions	Min	Typ	Max	Unit
V _{ESD(HBM)}	Electrostatic discharge voltage (human body model)	T _A =25 °C; JESD22-A114	—	—	7000	V
V _{ESD(CDM)}	Electrostatic discharge voltage (charge device model)	T _A =25 °C; JESD22-C101	—	—	1000	V

Table 4-8. Static latch-up characteristics

Symbol	Parameter	Conditions	Min	Typ	Max	Unit
LU	I-test	T _A =25 °C; JESD78	—	—	±100	mA
	V _{supply} over voltage		—	—	5.4	V

4.7. External clock characteristics

Table 4-9. High speed external clock (HXTAL) generated from a crystal/ceramic characteristics

Symbol	Parameter	Conditions	Min	Typ	Max	Unit
f _{HXTAL}	High Speed External oscillator (HXTAL) frequency	1.71<=V _{DD} <=3.6V	4	8	32	MHz
C _{HXTAL}	Recommended load capacitance on OSCIN and OSCOUT	—	—	20	30	pF
D _{HXTAL}	HXTAL oscillator duty cycle	—	30	50	70	%
I _{DDHXTAL}	HXTAL oscillator operating current	V _{DD} =3.3V, T _A =25°C	—	1.1	—	mA
t _{SUHSEHXTAL}	HXTAL oscillator startup time	V _{DD} =3.3V, T _A =25°C	—	2	—	ms

Table 4-10. High speed external user clock characteristics (HXTAL in bypass mode)

Symbol	Parameter	Conditions	Min	Typ	Max	Unit
F _{HXTAL_ext}	External user clock source frequency	—	1	—	50	MHz
V _H	OSCIN input pin high level voltage	—	0.7V _{DD}	—	V _{DD}	V
V _L	OSCIN input pin low level voltage	—	V _{SS}	—	0.3V _{DD}	V
T _w	OSCIN high or low time	—	5	—	—	ns

Symbol	Parameter	Conditions	Min	Typ	Max	Unit
T_r/T_f	OSCIN rise or fall time	—	—	—	10	ns
Ducy	Duty cycle	—	40	—	60	%

Table 4-11. Low speed external clock (LXTAL) generated from a crystal/ceramic characteristics

Symbol	Parameter	Conditions	Min	Typ	Max	Unit
f_{LXTAL}	Low Speed External oscillator (LXTAL) frequency	—	—	32.768		KHz
C_{LXTAL}	Recommended load capacitance on OSC32IN and OSC32OUT	—	—	10		pF
D_{LXTAL}	LXTAL oscillator duty cycle	—	30		70	%
$I_{DDLXTAL}$	LXTAL oscillator operating current	DRV[1:0]=00	—	0.7	—	μA
		DRV[1:0]=01	—	0.8	—	
		DRV[1:0]=10	—	1.1	—	
		DRV[1:0]=11	—	1.4	—	
$t_{SULXTAL}$	LXTAL oscillator startup time	—	—	2	—	s

Table 4-12. Low speed external user clock characteristics (LXTAL in bypass mode)

Symbol	Parameter	Conditions	Min	Typ	Max	Unit
f_{LXTAL_ext}	User external clock source frequency	—	—	32.768	1000	kHz
V_{LXTALH}	OSC32IN input pin high level voltage	—	$0.7V_{DD}$	—	V_{DD}	V
V_{LXTALL}	OSC32IN input pin low level voltage	—	V_{SS}	—	$0.3V_{DD}$	
$t_{w(LXTALH)}$ $t_{w(LXTALL)}$	OSC32IN high or low time	—	450	—	—	ns
$t_r(LXTAL)$ $t_f(LXTAL)$	OSC32IN rise or fall time	—	—	—	50	

4.8. Internal clock characteristics

Table 4-13. High speed internal clock (IRC8M) characteristics

Symbol	Parameter	Conditions	Min	Typ	Max	Unit
f_{IRC8M}	High Speed Internal Oscillator (IRC8M) frequency	$V_{DD}=3.3V$	—	8	—	MHz
ACC_{IRC8M}	IRC8M oscillator Frequency accuracy, Factory-trimmed	$V_{DD}=3.3V, T_A=-40^{\circ}C \sim +105^{\circ}C$	-3.0	—	3.0	%
		$V_{DD}=3.3V, T_A=0^{\circ}C \sim +85^{\circ}C$	-1.8	—	2.2	%
		$V_{DD}=3.3V, T_A=25^{\circ}C$	-1.0	—	1.0	%
	IRC8M oscillator Frequency accuracy, User trimming step	—	—	0.31	—	%
D_{IRC8M}	IRC8M oscillator duty cycle	$V_{DD}=3.3V, f_{IRC8M}=8MHz$	45	50	55	%
$I_{DDIRC8M}$	IRC8M oscillator operating current	$V_{DD}=3.3V, f_{IRC8M}=8MHz$	—	110	—	μA
$t_{SUIRC8M}$	IRC8M oscillator startup time	$V_{DD}=3.3V, f_{IRC8M}=8MHz$	1	—	2	us

Table 4-14. Low speed internal clock (IRC40K) characteristics

Symbol	Parameter	Conditions	Min	Typ	Max	Unit
f_{IRC40K}	Low Speed Internal oscillator(IRC40K) frequency	$V_{DD}=V_{BAT}=3.3V,$ $T_A=-40^{\circ}C \sim +85^{\circ}C$	28	40	60	KHz
$I_{DDIRC40K}$	IRC40K oscillator operating current	$V_{DD}=V_{BAT}=3.3V, T_A=25^{\circ}C$	—	0.42	—	μA
$t_{SUIRC40K}$	IRC40K oscillator startup time	$V_{DD}=V_{BAT}=3.3V, T_A=25^{\circ}C$	—	—	140	μs

Table 4-15. High speed internal clock (IRC48M) characteristics

Symbol	Parameter	Conditions	Min	Typ	Max	Unit
f_{IRC48M}	High Speed Internal Oscillator (IRC48M) frequency	$V_{DD}=3.3V$	—	48	—	MHz
ACC_{IRC48M}	IRC48M oscillator Frequency accuracy, Factory-trimmed	$V_{DD}=3.3V, T_A=-40^{\circ}C \sim +105^{\circ}C$	-4.0	—	5.0	%
		$V_{DD}=3.3V, T_A=0^{\circ}C \sim +85^{\circ}C$	-3.0	—	3.0	%
		$V_{DD}=3.3V, T_A=25^{\circ}C$	-2.0	—	2.0	%
	IRC48M oscillator Frequency accuracy, User trimming step	—	—	0.12	—	%
D_{IRC48M}	IRC48M oscillator duty cycle	$V_{DD}=3.3V, f_{IRC8M}=48MHz$	45	50	55	%
$I_{DDIRC48M}$	IRC48M oscillator operating current	$V_{DD}=3.3V, f_{IRC8M}=48MHz$	—	270	—	μA
$t_{SUIRC48M}$	IRC48M oscillator startup time	$V_{DD}=3.3V, f_{IRC8M}=48MHz$	1	—	2	us

4.9. PLL characteristics

Table 4-16. PLL, PLL1 and PLL2 characteristics

Symbol	Parameter	Conditions	Min	Typ	Max	Unit
f _{PLLIN}	PLL input clock frequency	—	2	8	25	MHz
f _{PLL}	PLL output clock frequency	—	16	—	120	MHz
F _{VCO}	VCO output frequency	—	32	—	240	MHz
t _{LOCK}	PLL lock time	—	—	—	300	μs

4.10. Memory characteristics

Table 4-17. Flash memory characteristics

Symbol	Parameter	Conditions	Min	Typ	Max	Unit
PE _{CYC}	Number of guaranteed program /erase cycles before failure(Endurance)	T _A =-40°C ~ +85°C	100	—	—	kcycles
t _{RET}	Data retention time	10k cycles at T _A =85°C	10	—	—	years
t _{PROG}	Word programming time	T _A =-40°C ~ +85°C	37	—	42	μs
t _{ERASE}	Page erase time	T _A =-40°C ~ +85°C	0.8	—	1.1	ms
t _{MERASE}	Mass erase time	T _A =-40°C ~ +85°C	3.2	—	4	ms

4.11. GPIO characteristics

Table 4-18. I/O port characteristics

Symbol	Parameter	Conditions	Min	Typ	Max	Unit
V _{IL}	Standard IO Low level input voltage	V _{DD} =1.8V	—	—	0.84	V
		V _{DD} =2.5V	—	—	—	
		V _{DD} =3.3V	—	—	1.5	
		V _{DD} =3.6V	—	—	1.63	
	5V-tolerant IO Low level input voltage	V _{DD} =1.8V	—	—	0.83	V
		V _{DD} =2.5V	—	—	—	
V _{DD} =3.3V		—	—	1.49		
V _{IH}	Standard IO High level input voltage	V _{DD} =1.8V	1.06	—	—	V
		V _{DD} =2.5V	—	—	—	
		V _{DD} =3.3V	1.73	—	—	
		V _{DD} =3.6V	1.86	—	—	
	5V-tolerant IO High level input voltage	V _{DD} =1.71V	—	—	—	V
		V _{DD} =1.8V	1.07	—	—	
		V _{DD} =2.5V	—	—	—	
		V _{DD} =3.3V	1.72	—	—	

Symbol	Parameter	Conditions	Min	Typ	Max	Unit
		$V_{DD}=3.6V$	1.86	—	—	
V_{OL}	Low level output voltage ($I_{IO} = +8mA$)	$V_{DD}=1.8V$	—	—	—	V
		$V_{DD}=2.5V$	—	—	—	
		$V_{DD}=3.3V$	—	—	0.11	
		$V_{DD}=3.6V$	—	—	0.11	
V_{OL}	Low level output voltage ($I_{IO} = +20mA$)	$V_{DD}=1.8V$	—	—	—	
		$V_{DD}=2.5V$	—	—	—	
		$V_{DD}=3.3V$	—	—	0.29	
		$V_{DD}=3.6V$	—	—	0.27	
V_{OH}	High level output voltage ($I_{IO} = +8mA$)	$V_{DD}=1.8V$	—	—	—	V
		$V_{DD}=2.5V$	—	—	—	
		$V_{DD}=3.3V$	3.14	—	—	
		$V_{DD}=3.6V$	3.45	—	—	
V_{OH}	High level output voltage ($I_{IO} = +20mA$)	$V_{DD}=1.8V$	—	—	—	
		$V_{DD}=2.5V$	—	—	—	
		$V_{DD}=3.3V$	2.90	—	—	
		$V_{DD}=3.6V$	3.22	—	—	
R_{PU}	Internal pull-up resistor	—	—	40	—	k Ω
R_{PD}	Internal pull-down resistor	—	—	40	—	k Ω

4.12. ADC characteristics

Table 4-19. ADC characteristics

Symbol	Parameter	Conditions	Min	Typ	Max	Unit
V _{DDA}	Operating voltage	—	2.4	3.3	3.6	V
V _{IN}	ADC input voltage range	—	0	—	V _{REF+}	V
f _{ADC}	ADC clock	—	0.1	—	42	MHz
f _s	Sampling rate	12-bit	0.007	—	3	MSP S
		10-bit	0.008	—	3.5	
		8-bit	0.01	—	4.2	
		6-bit	0.011	—	5.25	
V _{IN}	Analog input voltage	16 external;2 internal	0	—	V _{DDA}	V
V _{REF+}	Positive Reference Voltage	—	—	V _{DDA}	—	V
V _{REF-}	Negative Reference Voltage	—	—	0	—	V
R _{AIN}	External input impedance	See Equation 2	—	—	24	kΩ
R _{ADC}	Input sampling switch resistance	—	—	—	0.2	kΩ
C _{ADC}	Input sampling capacitance	No pin/pad capacitance included	—	—	5.5	pF
t _{CAL}	Calibration time	f _{ADC} =42MHz	—	3.12	—	μs
t _s	Sampling time	f _{ADC} =42MHz	0.036	—	5.7	μs
t _{CONV}	Total conversion time(including sampling time)	12-bit	—	14	—	1/ f _{ADC}
		10-bit	—	12	—	
		8-bit	—	10	—	
		6-bit	—	8	—	
t _{SU}	Startup time	—	—	—	1	μs

Equation 2: R_{AIN} max formula $R_{AIN} < \frac{T_s}{f_{ADC} * C_{ADC} * \ln(2^{N+2})} - R_{ADC}$

The formula above (Equation 2) is used to determine the maximum external impedance allowed for an error below 1/4 of LSB. Here N=12 (from 12-bit resolution).

Table 4-20. ADC R_{AIN} max for f_{ADC} = 40MHz

T _s (cycles)	t _s (us)	R _{AIN} max (KΩ)
1.5	0.04	0.47
7.5	0.18	3.15
13.5	0.32	5.82
28.5	0.68	12.55
41.5	0.99	18.35
55.5	1.32	24.55
71.5	1.70	NA
239.5	5.70	NA

Note: Guaranteed by design, not tested in production.

Table 4-21. ADC dynamic accuracy at $f_{ADC} = 14$ MHz

Symbol	Parameter	Test conditions	Min	Typ	Max	Unit
ENOB	Effective number of bits	$f_{ADC}=14\text{MHz}$	10.4	10.5	—	bits
SNDR	Signal-to-noise and distortion ratio	$V_{DDA}=V_{REF+}=3.3\text{V}$	64.4	65.0	—	dB
SNR	Signal-to-noise ratio	Input Frequency=20KHz	65.5	66.5	—	
THD	Total harmonic distortion	Temperature=25°C	-67.8	-68.9	—	

Table 4-22. ADC dynamic accuracy at $f_{ADC} = 42$ MHz

Symbol	Parameter	Test conditions	Min	Typ	Max	Unit
ENOB	Effective number of bits	$f_{ADC}=42\text{MHz}$	10.3	10.4	—	bits
SNDR	Signal-to-noise and distortion ratio	$V_{DDA}=V_{REF+}=3.3\text{V}$	63.8	64.4	—	dB
SNR	Signal-to-noise ratio	Input Frequency=20KHz	66.4	66.6	—	
THD	Total harmonic distortion	Temperature=25°C	-67.5	-68.6	—	

Table 4-23. ADC static accuracy at $f_{ADC} = 42$ MHz

Symbol	Parameter	Test conditions	Typ	Max	Unit
Offset	Offset error	$f_{ADC}=42\text{MHz}$ $V_{DDA}=V_{REF+}=3.3\text{V}$	± 0.5	± 1	LSB
DNL	Differential linearity error		± 0.9	± 1	
INL	Integral linearity error		± 2.5	± 3	

4.13. DAC characteristics

Table 4-24. DAC characteristics

Symbol	Parameter	Conditions	Min	Typ	Max	Unit
V_{DDA}	Operating voltage	—	1.71	3.3	3.6	V
V_{REF+}	Reference supply voltage	V_{REF+} should always below V_{DDA}	1.71	—	3.6	V
R_{LOAD}	Load resistance	Resistive load with buffer ON	5	—	—	k Ω
R_o	Impedance output with buffer OFF	—	—	—	15	k Ω
C_{LOAD}	Load capacitance	No pin/pad capacitance included	—	—	50	pF
DAC_OUT_min	Lower DAC_OUT voltage with buffer ON	—	0.2	—	—	V
DAC_OUT_max	Higher DAC_OUT voltage with buffer ON	—	—	—	$V_{DDA}-0.2$	V
DAC_OUT_min	Lower DAC_OUT voltage with buffer OFF	—	—	0.5m	—	V
DAC_OUT_min	Higher DAC_OUT voltage with buffer OFF	—	—	—	$V_{DDA}-1\text{LSB}$	V
I_{DDA}	DAC current consumption	With no load, middle	—	360	—	μA

Symbol	Parameter	Conditions	Min	Typ	Max	Unit
	in quiescent mode	code(0x800) on the input, $V_{REF+}=3.6V$				
		With no load, worst code(0xF1C) on the input, $V_{REF+}=3.6V$	—	440	—	uA
$I_{DDVREF+}$	DAC current consumption in quiescent mode	With no load, middle code(0x800) on the input, $V_{REF+}=3.6V$	—	120	—	uA
		With no load, worst code(0xF1C) on the input, $V_{REF+}=3.6V$	—	320	—	uA
DNL	Differential non-linearity error	DAC in 12-bit mode	—	—	± 2	LSB
INL	Integral non-linearity	DAC in 12-bit mode	—	—	± 4	LSB
Offset	Offset error	DAC in 12-bit mode	—	—	± 12	LSB
GE	Gain error	DAC in 12-bit mode	—	—	± 0.5	%
$T_{setting}$	Settling time	$C_{LOAD} \leq 50pF, R_{LOAD} \geq 5k\Omega$	—	0.6	1	us
Update rate	Max frequency for a correct DAC_OUT change from code i to $i \pm 1$ LSBs	$C_{LOAD} \leq 50pF, R_{LOAD} \geq 5k\Omega$	—	—	4	MS/s
PSRR	Power supply rejection ratio (to V_{DDA})	—	65	80	—	dB

4.14. I2C characteristics

Table 4-25. I2C characteristics

Symbol	Parameter	Conditions	Standard mode		Fast mode		Fast mode plus		Unit
			Min	Max	Min	Max	Min	Max	
f_{SCL}	SCL clock frequency	—	0	100	0	400	0	1000	KHz
$t_{SCL(H)}$	SCL clock high time	—	4.0	—	0.6	—	0.2	—	ns
$t_{SCL(L)}$	SCL clock low time	—	4.7	—	1.3	—	0.5	—	ns

4.15. SPI characteristics

Table 4-26. Standard SPI characteristics

Symbol	Parameter	Conditions	Min	Typ	Max	Unit
f_{SCK}	SCK clock frequency	—	—	—	30	MHz

$t_{SCK(H)}$	SCK clock high time	—	15	17	19	ns
$t_{SCK(L)}$	SCK clock low time	—	15	17	19	ns
SPI master mode						
$t_{V(MO)}$	Data output valid time	—	—	—	11	ns
$t_{H(MO)}$	Data output hold time	—	0	—	—	ns
$t_{SU(MI)}$	Data input setup time	—	0	—	—	ns
$t_{H(MI)}$	Data input hold time	—	3	—	—	ns
SPI slave mode						
$t_{SU(NSS)}$	NSS enable setup time	$f_{PCLK}=60MHz$	33	—	—	ns
$t_{H(NSS)}$	NSS enable hold time	$f_{PCLK}=60MHz$	33	—	—	ns
$t_{A(SO)}$	Data output access time	$f_{PCLK}=60MHz$	3	—	11	ns
$t_{DIS(SO)}$	Data output disable time	—	3	—	10	ns
$t_{V(SO)}$	Data output valid time	—	—	—	17	ns
$t_{H(SO)}$	Data output hold time	—	15	—	—	ns
$t_{SU(SI)}$	Data input setup time	—	0	—	—	ns
$t_{H(SI)}$	Data input hold time	—	3	—	—	ns

5. Package information

5.1. QFN package outline dimensions

Figure 5-1. QFN package outline

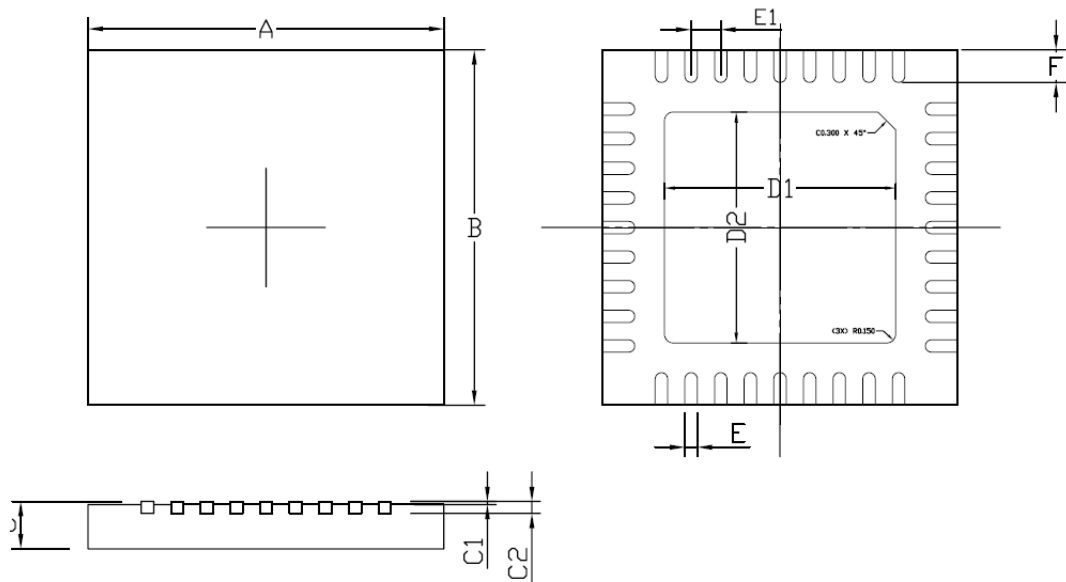

Table 5-1. QFN package dimensions

Symbol	Dimensions (mm)		Symbol	Dimensions (mm)	
	min	max		min	max
A	6.0 ± 0.1		D1	3.90 Typ	
B	6.0 ± 0.1		D2	3.90 Typ	
C	0.85	0.95	E	0.210 ± 0.025	
C1	0~0.050		E1	0.500 Typ	
C2	0.203 Typ		F	0.550 Typ	

(Original dimensions are in millimeters)

Notes:

1. Formed lead shall be planar with respect to one another within 0.004 inches.
2. Both package length and width do not include mold flash and metal burr.

5.2. LQFP package outline dimensions

Figure 5-2. LQFP package outline

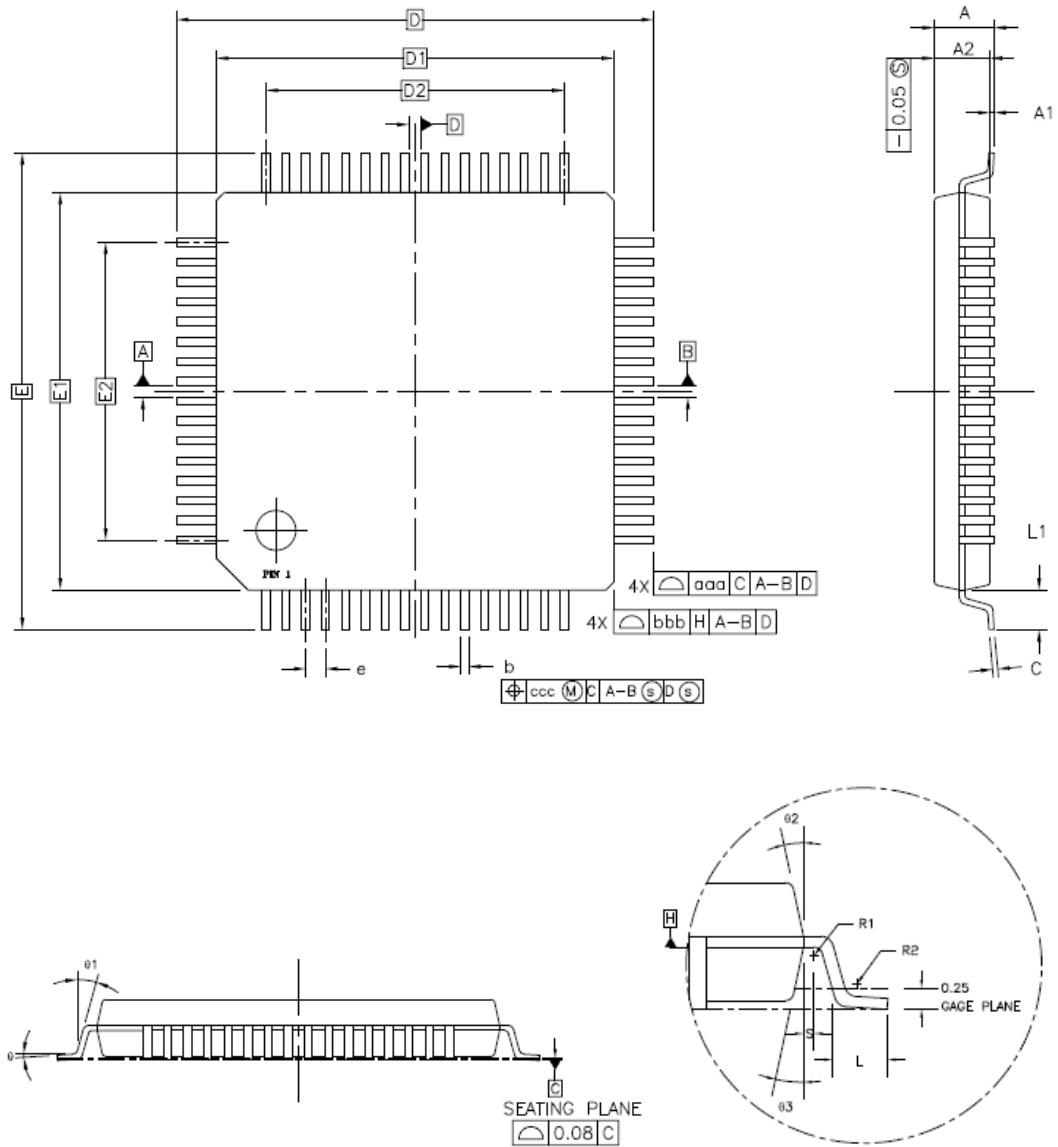

Table 5-2. LQFP package dimensions

Symbol	LQFP48			LQFP64			LQFP100		
	Min	Typ	Max	Min	Typ	Max	Min	Typ	Max
A	1.20	-	1.50	-	-	1.60	-	-	1.60
A1	0.05	-	0.15	0.05	-	0.15	0.05	-	0.15
A2	0.95	1.00	1.35	1.35	1.40	1.45	1.35	1.40	1.45
D	-	9.00	-	-	12.00	-	-	16.00	-
D1	-	7.00	-	-	10.00	-	-	14.00	-
E	-	9.00	-	-	12.00	-	-	16.00	-
E1	-	7.00	-	-	10.00	-	-	14.00	-
R1	0.08	-	-	0.08	-	-	0.08	-	-
R2	0.08	-	0.20	0.08	-	0.20	0.08	-	0.20
θ	0°	3.5°	7°	0°	3.5°	7°	0°	3.5°	7°
θ_1	0°	-	-	0°	-	-	0°	-	-
θ_2	11°	12°	13°	11°	12°	13°	11°	12°	13°

Symbol	LQFP48			LQFP64			LQFP100		
	Min	Typ	Max	Min	Typ	Max	Min	Typ	Max
θ3	11°	12°	13°	11°	12°	13°	11°	12°	13°
c	0.09	-	0.20	0.09	-	0.20	0.09	-	0.20
L	0.45	0.60	0.75	0.45	0.60	0.75	0.45	0.60	0.75
L1	-	1.00	-	-	1.00	-	-	1.00	-
S	0.20	-	-	0.20	-	-	0.20	-	-
b	0.17	0.22	0.27	0.17	0.20	0.27	0.17	0.20	0.27
e	-	0.50	-	-	0.50	-	-	0.50	-
D2	-	5.50	-	-	7.50	-	-	12.00	-
E2	-	5.50	-	-	7.50	-	-	12.00	-
aaa	0.20			0.20			0.20		
bbb	0.20			0.20			0.20		
ccc	0.08			0.08			0.08		

(Original dimensions are in millimeters)

6. Ordering information

Table 6-1. Part ordering code for GD32E103xx devices

Ordering code	Flash (KB)	Package	Package type	Temperature operating range
GD32E103T8U6	64	QFN36	Green	Industrial -40°C to +85°C
GD32E103TBU6	128	QFN36	Green	Industrial -40°C to +85°C
GD32E103C8T6	64	LQFP48	Green	Industrial -40°C to +85°C
GD32E103CBT6	128	LQFP48	Green	Industrial -40°C to +85°C
GD32E103R8T6	64	LQFP64	Green	Industrial -40°C to +85°C
GD32E103RBT6	128	LQFP64	Green	Industrial -40°C to +85°C
GD32E103V8T6	64	LQFP100	Green	Industrial -40°C to +85°C
GD32E103VBT6	128	LQFP100	Green	Industrial -40°C to +85°C

7. Revision history

Table 7-1. Revision history

Revision No.	Description	Date
1.0	Initial Release	Dec. 26, 2017