

# Current Sense Transformers CST2010



- AEC-Q200 Grade 1 qualified (–40°C to +125°C ambient)
- Sensed current up to 40 A; Frequency range up to 1 MHz
- Very low primary DC resistance
- 500 Vrms, one minute isolation (hipot) between windings.

**Core material** Ferrite

**Terminations** RoHS compliant tin-silver over tin over nickel over phos bronze

**Weight** 4.13 g

**Ambient temperature** –40°C to +125°C

**Maximum part temperature** +165°C (ambient + temp rise)

**Storage temperature** Component: –40°C to +125°C.

Tape and reel Packaging: –40°C to +80°C

**Resistance to soldering heat** Max three 40 second reflows at +260°C, parts cooled to room temperature between cycles

**Moisture Sensitivity Level (MSL)** 1 (unlimited floor life at <30°C / 85% relative humidity)

**Failures in Time (FIT) / Mean Time Between Failures (MTBF)**

38 per billion hours / 26,315,789 hours, calculated per Telcordia SR-332

**Packaging** 300/13" reel; Plastic tape: 32 mm wide, 0.5 mm thick, 20 mm pocket spacing, 10.6 mm pocket depth

**PCB washing** Tested to MIL-STD-202 Method 215 plus an additional aqueous wash. See [Doc787\\_PCB\\_Washing.pdf](#).

Part number <sup>1</sup>	Turns (N) pri:sec	Inductance <sup>2</sup> min (mH)	DCR max (Ohms)		Frequency range (kHz)	Volt-time product <sup>3</sup> (Vµsec)	Sensed current I <sub>in</sub> <sup>4</sup> max (A)	Terminating resistance R <sub>T</sub> <sup>5</sup> (Ohms)
			pri	sec				
CST2010-020L_	1:20	0.34	0.00036	0.180	10 – 1000	50.8	40	0.5
CST2010-030L_	1:30	0.76	0.00036	0.265	7 – 1000	76.2	40	0.8
CST2010-040L_	1:40	1.36	0.00036	0.560	5 – 1000	101.6	40	1.0
CST2010-050L_	1:50	2.12	0.00036	0.705	4 – 1000	127.0	40	1.3
CST2010-060L_	1:60	3.06	0.00036	0.850	3 – 1000	152.4	40	1.5
CST2010-070L_	1:70	4.16	0.00036	1.00	3 – 1000	177.8	40	1.8
CST2010-080L_	1:80	5.44	0.00036	1.15	2 – 1000	203.2	40	2.0
CST2010-100L_	1:100	8.50	0.00036	1.45	2 – 1000	254.0	40	2.5
CST2010-125L_	1:125	13.3	0.00036	1.85	2 – 1000	317.5	40	3.1
CST2010-150L_	1:150	19.2	0.00036	2.25	1 – 1000	381.0	40	3.8
CST2010-200L_	1:200	34.0	0.00036	4.06	1 – 1000	508.0	40	5.0

1. When ordering, please specify **packaging** code:

CST2010-200LD

**Packaging:** D = 13" machine-ready reel. EIA-481 embossed plastic tape (300 parts per full reel).

B = Less than full reel. In tape, but not machine ready.  
To have a leader and trailer added (\$25 charge), use code letter D instead.

- Inductance measured between secondary pins at 1 kHz, 0.1 Vrms, 0 Adc.
- Maximum volt-time product is for the secondary, based on 2000 Gauss.
- Primary current of 40 A causes less than 25°C temperature rise from 25°C ambient. Higher current causes a greater temperature rise (see Temperature Rise vs Current curve).
- Terminating resistance (R<sub>T</sub>) value is based on 1 Volt output with 40 Amps flowing through the primary. Varying terminating resistance increases or decreases output Voltage/Ampere according to the following equation:  
$$R_T = V_{out} \times N_{sec} / I_{in}$$
- Electrical specifications at 25°C.

Refer to Doc 362 "Soldering Surface Mount Components" before soldering.

## Typical Circuit

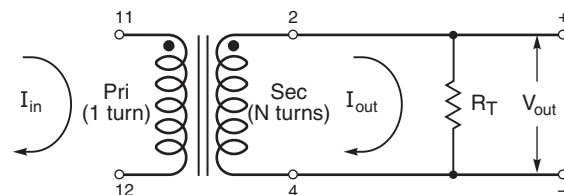



# CST2010 SMT Current Sense Transformers

## Temperature Rise vs Current

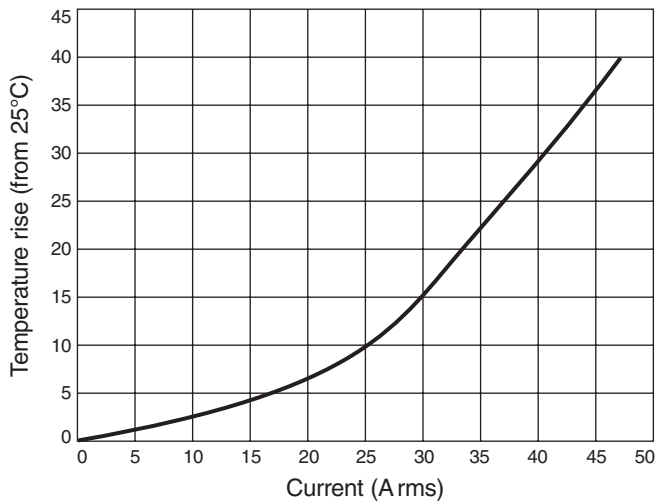

## Dimensions

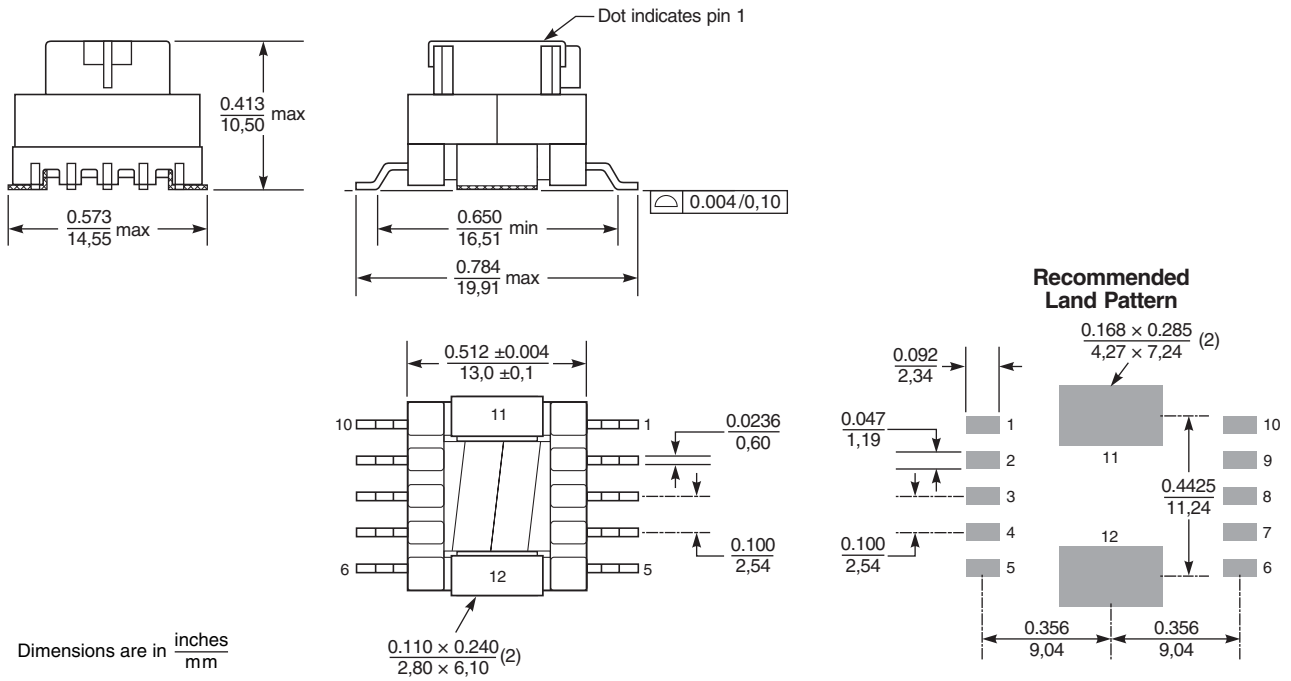

**US** +1-847-639-6400 sales@coilcraft.com  
**UK** +44-1236-730595 sales@coilcraft-europe.com  
**Taiwan** +886-2-2264 3646 sales@coilcraft.com.tw  
**China** +86-21-6218 8074 sales@coilcraft.com.cn  
**Singapore** + 65-6484 8412 sales@coilcraft.com.sg

Document 1100-2 Revised 04/25/16  
 © Coilcraft Inc. 2018  
 This product may not be used in medical or high risk applications without prior Coilcraft approval. Specification subject to change without notice. Please check web site for latest information.

# Mouser Electronics

Authorized Distributor

Click to View Pricing, Inventory, Delivery & Lifecycle Information:

## Coilcraft:

[CST2010-060LD](#) [CST2010-150LD](#) [CST2010-125LB](#) [CST2010-070LD](#) [CST2010-050LD](#) [CST2010-020LB](#)  
[CST2010-100LB](#) [CST2010-080LD](#) [CST2010-150LB](#) [CST2010-020LD](#) [CST2010-070LB](#) [CST2010-030LD](#) [CST2010-100LD](#) [CST2010-200LD](#) [CST2010-040LB](#) [CST2010-050LB](#) [CST2010-030LB](#) [CST2010-125LD](#) [CST2010-200LB](#)  
[CST2010-040LD](#) [CST2010-080LB](#) [CST2010-060LB](#)