

IM69D120

High performance digital XENSIV™ MEMS microphone

Description

The IM69D120 is designed for applications where low self-noise (high SNR), wide dynamic range, low distortions and a high acoustic overload point is required.

Infineon's Dual Backplate MEMS technology is based on a miniaturized symmetrical microphone design, similar as utilized in studio condenser microphones, and results in high linearity of the output signal within a dynamic range of 95dB. The microphone distortion does not exceed 1% even at sound pressure levels of 118dB SPL. The flat frequency response (28Hz low-frequency roll-off) and tight manufacturing tolerance result in close phase matching of the microphones, which is important for multi-microphone (array) applications.

With its low equivalent noise floor of 25dB SPL (SNR 69dB(A)) the microphone is no longer the limiting factor in the audio signal chain and enables higher performance of voice recognition algorithms.

The digital microphone ASIC contains an extremely low-noise preamplifier and a high-performance sigma-delta ADC. Different power modes can be selected in order to suit specific current consumption requirements.

Each IM69D120 microphone is calibrated with an advanced Infineon calibration algorithm, resulting in small sensitivity tolerances (± 1 dB). The phase response is tightly matched ($\pm 2^\circ$) between microphones, in order to support beamforming applications.

Features

- Dynamic range of 95dB
 - Signal to noise ratio of 69dB(A) SNR
 - <1% total harmonic distortions up to 118dB SPL
 - Acoustic overload point at 120dB SPL
- Sensitivity (± 1 dB) and phase ($\pm 2^\circ$ @1kHz) matched
- Flat frequency response with low frequency roll off at 28Hz
- Very fast analog to digital conversion speed (6 μ s latency @1kHz)
- Power optimized modes determined by PDM clock frequency
- Package dimensions: 4mm x 3mm x 1.2mm
- PDM output
- Omnidirectional pickup pattern

Typical applications

- Devices with Voice User Interface (VUI)
 - Smart speakers
 - Home automation
 - IOT devices
- Active Noise Cancellation (ANC) headphones and earphones
- High quality audio capturing
 - Conference systems
 - Cameras and camcorders
- Industrial or home monitoring with audio pattern detection

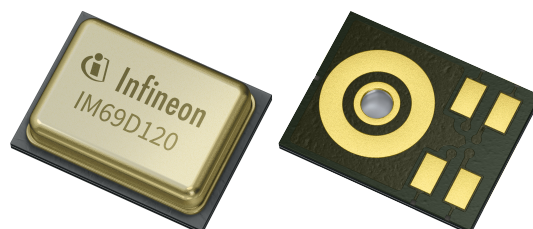

Use cases

Use cases

- Below 1% total harmonic distortion
 - Voice command during music from the loud speaker
 - Effective active noise cancellation even close to loud noise source
 - Recordings in a discotheque or at a rock concert
- High Signal to noise ratio
 - Far field audio signal pick-up
 - Low volume audio and whispered voice capturing
 - Microphone noise is no longer limiting the audio chain
- Sensitivity and phase matching
 - Full utilization of voice algorithms capability
 - Audio beam forming
 - High and precise attenuation of background noise
- Power optimized modes
 - Low current consumption for always on applications
 - Long operating time of battery powered devices

Block diagram

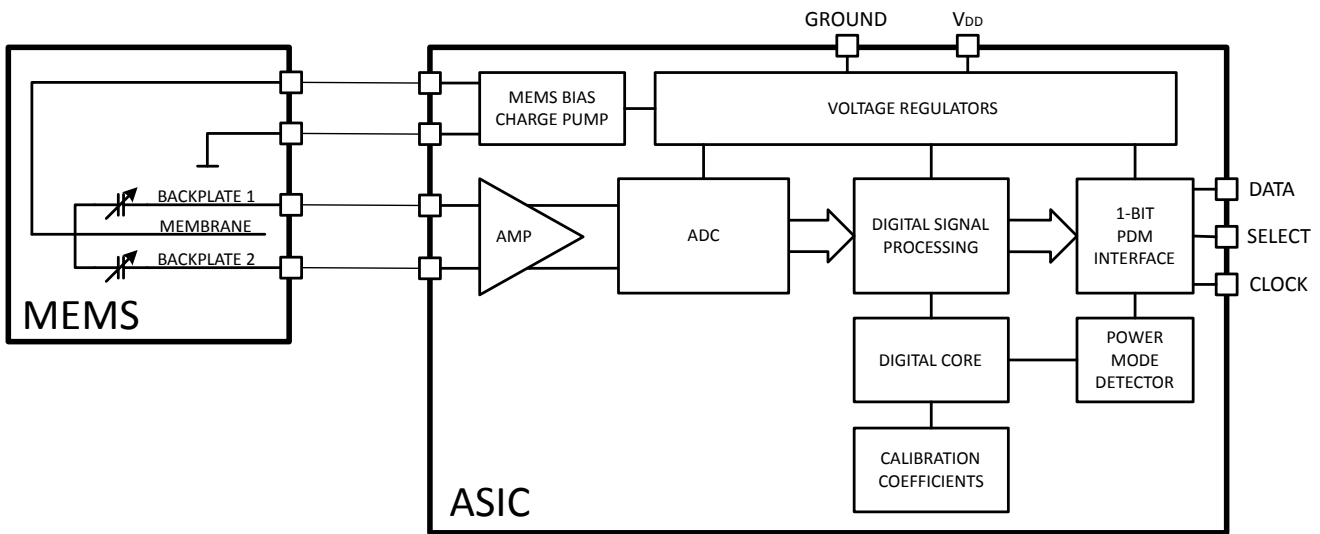

Figure 1 IM69D120 block diagram

Product validation

Technology qualified for industrial applications.

Ready for validation in industrial applications according to the relevant tests of IEC 60747 and 60749 or alternatively JEDEC47/20/22.

Table of contents

| | | |
|----------|--|----|
| | Description | 1 |
| | Features | 1 |
| | Typical applications | 1 |
| | Use cases | 2 |
| | Block diagram | 2 |
| | Product validation | 2 |
| | Table of contents | 3 |
| 1 | Typical performance characteristics | 4 |
| 2 | Acoustic characteristics | 5 |
| 2.1 | Free field frequency response | 6 |
| 3 | Electrical parameters and characteristics | 7 |
| 3.1 | Absolute maximum ratings | 7 |
| 3.2 | Electrical parameters | 7 |
| 3.3 | Electrical characteristics | 8 |
| 4 | Typical stereo application circuit | 10 |
| 5 | Reliability specifications | 11 |
| 6 | Package information | 12 |
| 7 | Footprint and stencil recommendation | 13 |
| 8 | Packing | 14 |
| | Revision history | 15 |
| | Disclaimer | 16 |

Typical performance characteristics

1 Typical performance characteristics

Test conditions: $V_{DD} = 1.8V$, $f_{CLK} = 3.072MHz$, no load on DATA

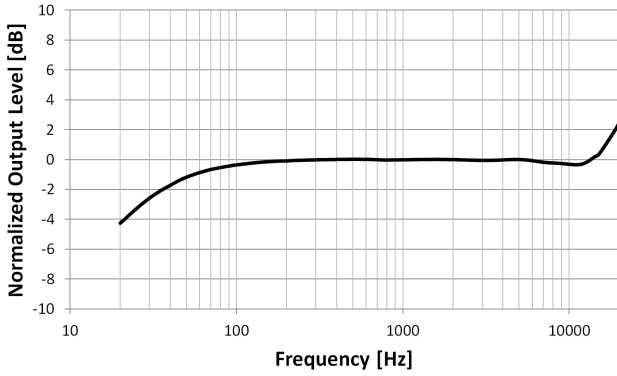

Figure 2 Typical freefield frequency response

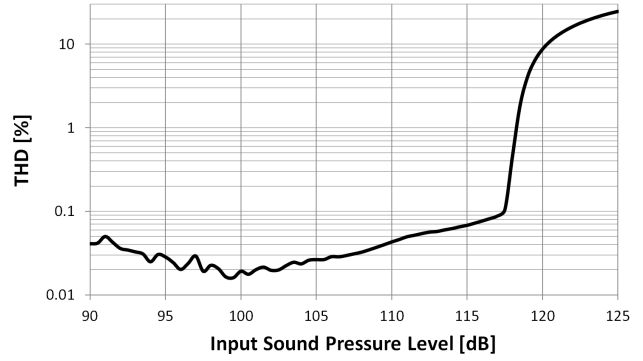

Figure 3 Typical THD vs SPL

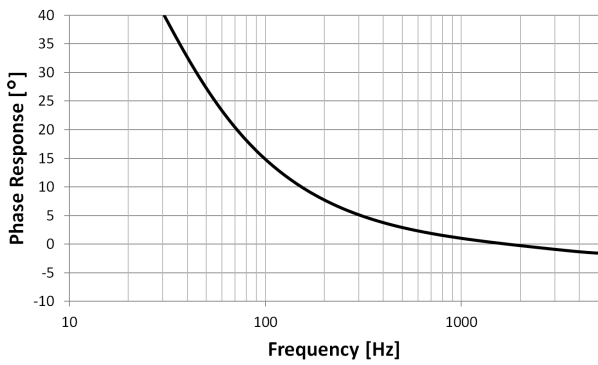

Figure 4 Typical phase response vs frequency

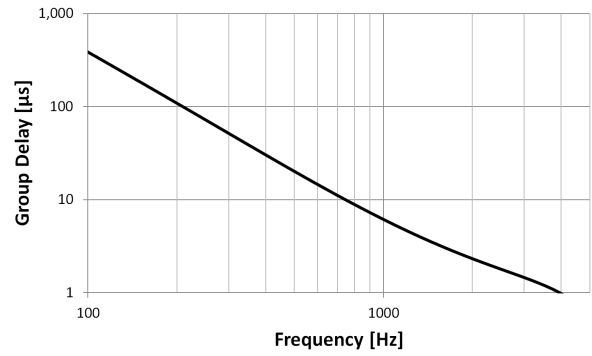

Figure 5 Typical group delay vs frequency

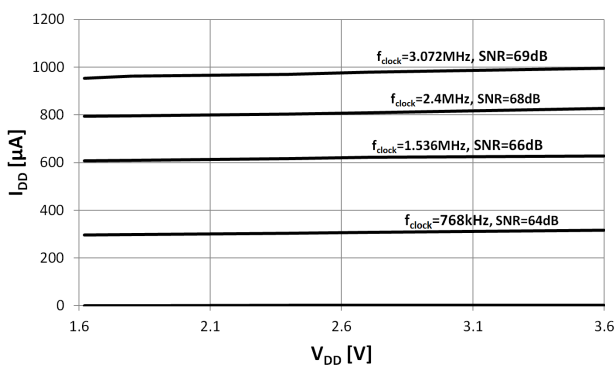

Figure 6 Typical I_{DD} vs V_{DD}

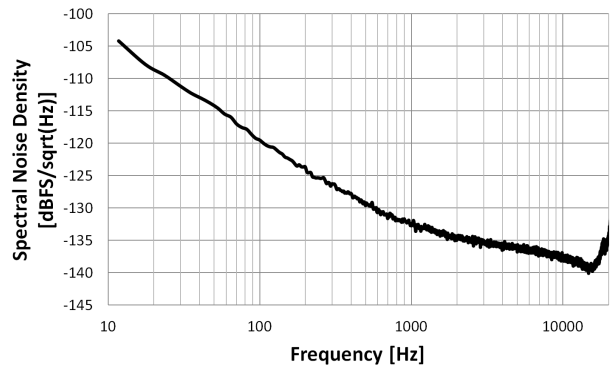

Figure 7 Typical noise floor (unweighted)

Acoustic characteristics

2 Acoustic characteristics

Test conditions (unless otherwise specified in the table): $V_{DD} = 1.8V$, $f_{CLK} = 3.072MHz$, $T_A = 25^{\circ}C$, 55% R.H., audio bandwidth 20Hz to 20kHz, select pin grounded, no load on DATA, $T_{edge} = 9ns$

Table 1 IM69D130 acoustic specifications

| Parameter | Symbol | Values | | | Unit | Note or Test condition |
|----------------------------|----------------------|---|------|------|---------|---|
| | | Min. | Typ. | Max. | | |
| Sensitivity | | -27 | -26 | -25 | dBFS | 1kHz, 94 dB SPL, all operating modes |
| Acoustic Overload Point | AOP | | 120 | | dB SPL | THD = 10%, all operating modes |
| Signal to Noise Ratio | $f_{clock}=3.072MHz$ | SNR | | 69 | dB(A) | A-Weighted 20Hz to 8kHz bandwidth, A-Weighted |
| | $f_{clock}=2.4MHz$ | | | 68 | | |
| | $f_{clock}=1.536MHz$ | | | 66 | | |
| | $f_{clock}=768kHz$ | | | 64 | | |
| Noise Floor | $f_{clock}=3.072MHz$ | | | -95 | dBFS(A) | A-Weighted 20Hz to 8kHz bandwidth, A-Weighted |
| | $f_{clock}=2.4MHz$ | | | -94 | | |
| | $f_{clock}=1.536MHz$ | | | -92 | | |
| | $f_{clock}=768kHz$ | | | -90 | | |
| Total Harmonic Distortion | 94dB SPL | THD | | 0.5 | % | Measuring 2nd to 5th harmonics; 1kHz, all operating modes |
| | 118dB SPL | | | 1.0 | | |
| | 119dB SPL | | | 2.0 | | |
| | 120dB SPL | | | 10.0 | | |
| Low Frequency Cutoff Point | f_{CLP} | | 28 | | Hz | -3dB point relative to 1kHz |
| Group Delay | 250Hz | | | 70 | μs | |
| | 600Hz | | | 15 | | |
| | 1kHz | | | 6 | | |
| | 4kHz | | | 1 | | |
| Phase Response | 75Hz | | | 19 | ° | |
| | 1kHz | | | 2 | | |
| | 3kHz | | | -1 | | |
| Directivity | | Omnidirectional | | | | Pickup pattern |
| Polarity | | Positive pressure increases density of 1's, negative pressure decreases density of 1's in data output | | | | |

Acoustic characteristics

2.1 Free field frequency response

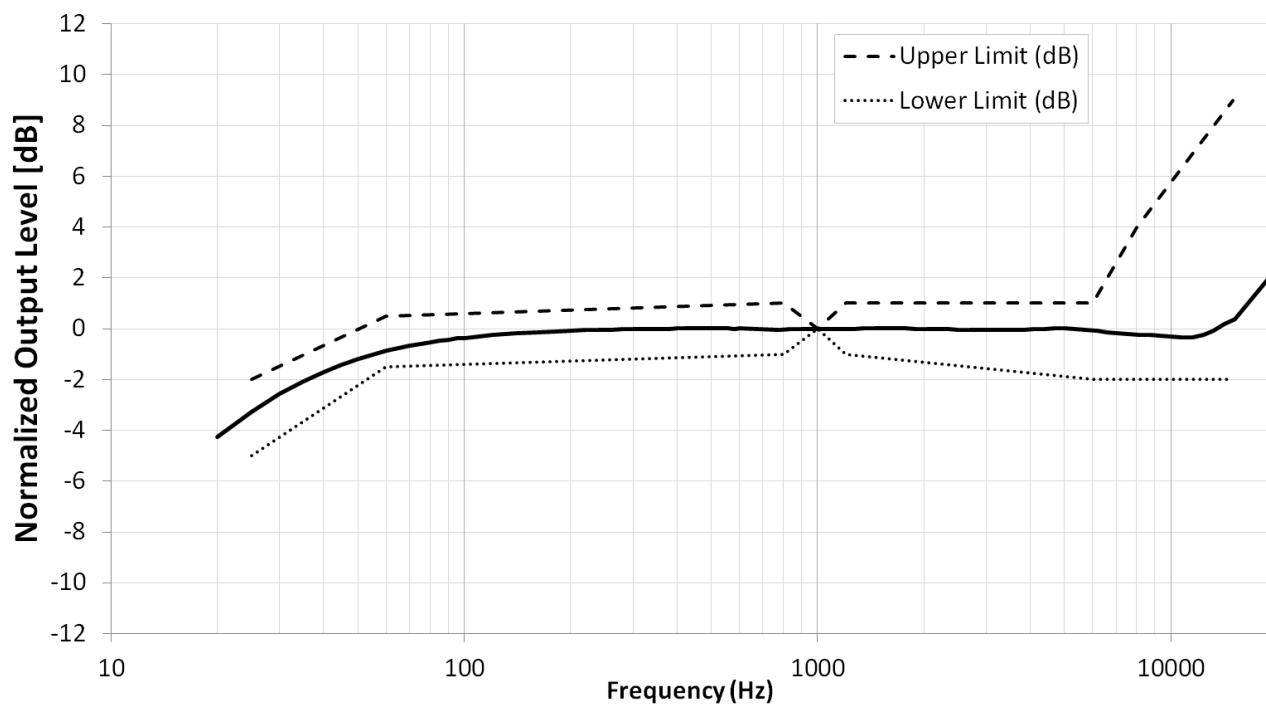

Figure 8 IM69D120 free field frequency response

Table 2 IM69D120 free field frequency response, normalized to 1kHz sensitivity value

| Frequency (Hz) | Upper Limit (dB) | Lower Limit (dB) |
|----------------|------------------|------------------|
| 25 | -2 | -5 |
| 60 | +0.5 | -1.5 |
| 800 | +1 | -1 |
| 1000 | 0 | 0 |
| 1200 | +1 | -1 |
| 6000 | +1 | -2 |
| 8000 | +4 | -2 |
| 15000 | +9 | -2 |

Electrical parameters and characteristics

3 Electrical parameters and characteristics

3.1 Absolute maximum ratings

Stresses at or above the listed maximum ratings may affect device reliability or cause permanent device damage. Functional device operation at these conditions is not guaranteed.

Table 3 Absolute maximum ratings

| Parameter | Symbol | Values | | Unit | Note / Test Condition |
|---------------------|-----------|--------|------|------|-----------------------|
| | | Min. | Max. | | |
| Voltage on any Pin | V_{max} | | 4 | V | |
| Storage Temperature | T_S | -40 | 125 | °C | |
| Ambient Temperature | T_A | -40 | 70 | °C | $V_{DD} > 3.0V$ |
| | | -40 | 100 | °C | |

3.2 Electrical parameters

Table 4 Electrical parameters and digital interface input

| Parameter | | Symbol | Values | | | Unit | Note / Test Condition |
|---------------------------------|-----------------|-------------|----------------------|-------|----------------------|------|--|
| | | | Min. | Typ. | Max. | | |
| Supply Voltage | | V_{DD} | 1.62 | | 3.6 | V | A 100nF bypass capacitor should be placed close to the microphone's VDD pin to ensure best SNR performance |
| Clock Frequency Range | Operating Modes | f_{clock} | 2.9 | 3.072 | 3.3 | MHz | DATA = high-Z |
| | | | 2.1 | 2.4 | 2.65 | | |
| | | | 1.05 | 1.536 | 1.9 | | |
| | 400 | | 768 | 950 | kHz | | |
| Standby Mode | | | | | 250 | | |
| V_{DD} Ramp-up Time | | | | | 50 | ms | Time until $V_{DD} \geq V_{DD_min}$ |
| PDM Clock Frequency | | f_{clock} | 0.4 | | 3.3 | MHz | |
| Clock Duty Cycle | | | 40 | | 60 | % | $f_{clock} < 2.65MHz$ |
| | | | 48 | | 52 | % | $f_{clock} \geq 2.9MHz$ |
| Clock Rise/Fall Time | | | | | 13 | ns | |
| Input Logic Low Level | | V_{IL} | -0.3 | | $0.35 \times V_{DD}$ | V | |
| Input Logic High Level | | V_{IH} | $0.65 \times V_{DD}$ | | $V_{DD} + 0.3$ | V | |
| Output Load Capacitance on DATA | | C_{load} | | | 200 | pF | |

Electrical parameters and characteristics

3.3 Electrical characteristics

Test conditions (unless otherwise specified in the table): $V_{DD}=1.8V$, $T_A=25^{\circ}C$, 55% R.H.

Table 5 General electrical characteristics

| Parameter | | Symbol | Values | | | Unit | Note / Test Condition |
|--|----------------------------------|------------------|--------------|------|---------------|---------|---|
| | | | Min. | Typ. | Max. | | |
| Current Consumption | $f_{clock}=3.072MHz$ | I_{DD} | | 980 | 1300 | μA | No load on DATA |
| | $f_{clock}=2.4MHz$ | | | 800 | 1050 | | |
| | $f_{clock}=1.536MHz$ | | | 620 | 800 | | |
| | $f_{clock}=768kHz$ | | | 300 | 380 | | |
| | Standby Mode | $I_{standby}$ | | 25 | 50 | | |
| | Clock Off Mode | I_{clock_off} | | | 1 | | CLOCK pulled low |
| Short Circuit Current | | | 1 | | 20 | mA | Grounded DATA pin |
| Power Supply Rejection | | PSR_{1k_NM} | | -80 | | dBFS | 100mV _{pp} sine wave on V_{DD} swept from 200Hz to 20kHz |
| | | PSR_{217_NM} | | -86 | | dBFS(A) | 100mV _{rms} , 217Hz square wave on V_{DD} . A-weighted |
| Startup Time | $\pm 0.5dB$ sensitivity accuracy | | | | 20 | ms | Time to start up in all operating modes after V_{DD_min} and CLOCK have been applied |
| | $\pm 0.2dB$ sensitivity accuracy | | | | 50 | | |
| Mode Switch Time | $\pm 0.5dB$ sensitivity accuracy | | | | 20 | ms | Time to switch between operating modes. V_{DD} remains on during the mode switch |
| | $\pm 0.2dB$ sensitivity accuracy | | | | 50 | | |
| Hysteresis Width | | V_{hys} | $0.1xV_{DD}$ | | $0.29xV_{DD}$ | V | |
| Output Logic Low Level | | V_{OL} | | | $0.3xV_{DD}$ | V | $I_{out}=2mA$ |
| Output Logic High Level | | V_{OH} | $0.7xV_{DD}$ | | | | $I_{out}=2mA$ |
| Delay Time for DATA Driven | | t_{DD} | 40 | | 80 | ns | Delay time from CLOCK edge ($0.5xV_{DD}$) to DATA driven |
| Delay Time for DATA High-Z ¹⁾ | | t_{HZ} | 5 | | 30 | ns | Delay time from CLOCK edge ($0.5xV_{DD}$) to DATA high impedance state |

¹ t_{hold} is depended on C_{load}

Electrical parameters and characteristics

Table 5 General electrical characteristics (continued)

| Parameter | Symbol | Values | | | Unit | Note / Test Condition |
|---|----------|--------|------|------|------|---|
| | | Min. | Typ. | Max. | | |
| Delay Time for DATA Valid ²⁾ | t_{DV} | | | 100 | ns | Delay time from CLOCK edge ($0.5 \times V_{DD}$) to DATA valid ($< 0.3 \times V_{DD}$ or $> 0.7 \times V_{DD}$) |

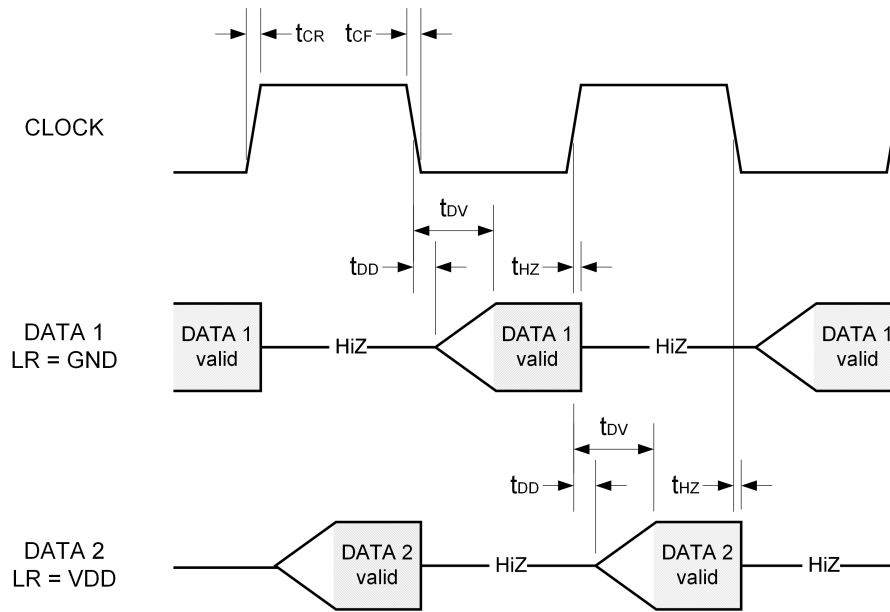

Figure 9 Timing diagram

²⁾ Load on data: $C_{load}=100pF$, $R_{load}=100k\Omega$

4 Typical stereo application circuit

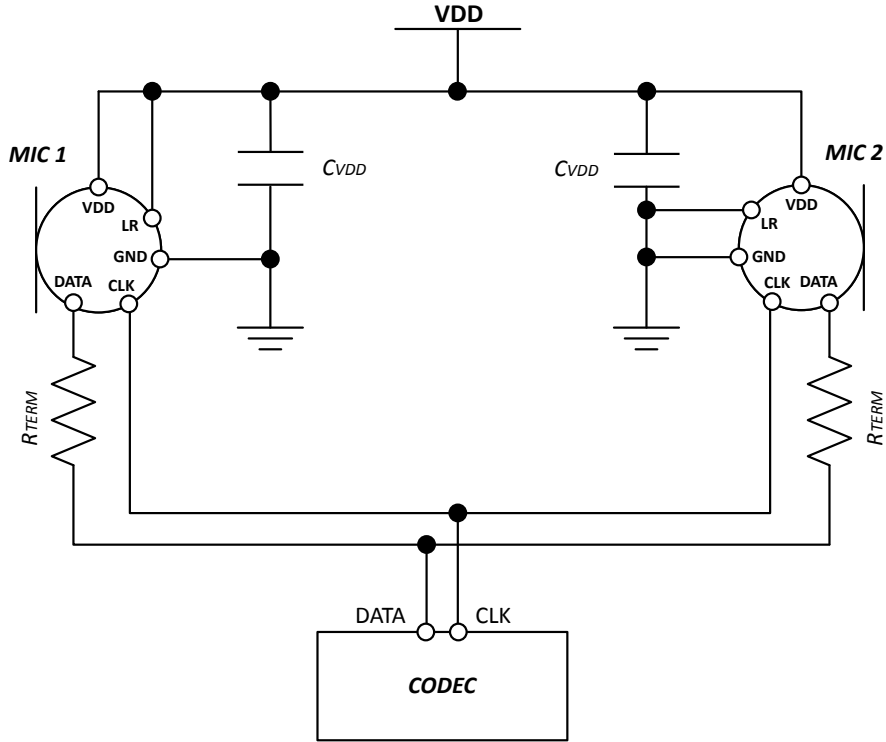

Figure 10 IM69D120 stereo mode configuration

Note: For best performance it is strongly recommended to place a 100nF ($C_{VDD_typical}$) capacitor between V_{DD} and ground. The capacitor should be placed as close to V_{DD} as possible. A termination resistor (R_{TERM}) of about 100Ω may be added to reduce the ringing and overshoot on the output signal.

Reliability specifications

5 Reliability specifications

The microphone sensitivity after stress must deviate by no more than 3dB from the initial value.

Table 6 Reliability tests

| Test | Test Condition | Standard |
|----------------------------|--|-------------------------|
| Vibration | 20Hz to 2000Hz with a peak acceleration of 20g in X, Y, and Z for 4 minutes each, total 4 cycles | MIL-STD-883J |
| High Temperature Storage | T _a =+125°C, 1000 hours | JESD22 A-103E |
| Low Temperature Storage | T _a =-40°C, 1000 hours | JESD22-A119A |
| High Temperature Operation | T _a =+125°C, VDD=2.5V, 1000 hours | JESD22 A-108D |
| Cold Temperature Operation | T _a =-40°C, VDD=3.2V, 1000 hours | JESD22 A-108D |
| Temperature/Humidity Bias | T _a =+85°C, R.H = 85%, VDD=3.2V, 1000 hours | JESD22-A101D |
| Mechanical Shock | 10000g/0.1msec direction ±x,y,z, 5 shocks in each direction, 30 shocks in total | IEC 60068-2-27 |
| Thermal cycle | 1000 cycles, -40°C to +125°C, 30 minutes per cycle | JESD22.A104E |
| Reflow Solder | 3 reflow cycles, peak temperature = +260°C | IPC-JEDEC J-STD-020D-01 |
| ESD-SLT | 3 contact discharges of ±8kV to lid while V _{dd} and f _{clock} are supplied according to the operational modes; (V _{dd} and f _{clock} ground is separated from earth ground) | IEC-61000-4-2 |
| ESD-HBM | 1 pulse of ±2kV between all I/O pin combinations | JS001 |
| Latch up | Trigger current from ±150mA | JESD 78E |

Package information

6 Package information

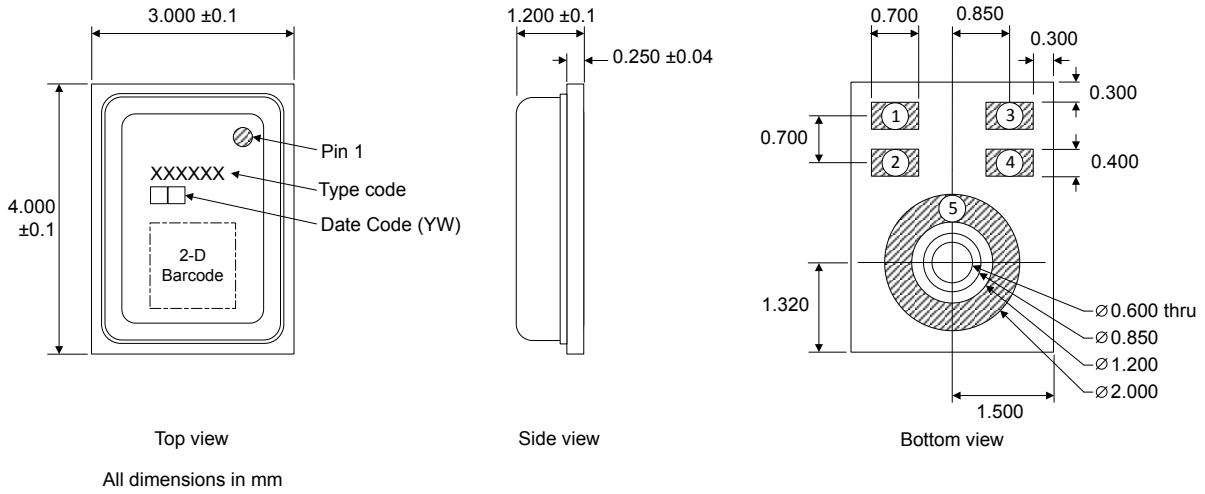

Figure 11 IM69D120 package drawing

Table 7 IM69D120 pin configuration

| Pin Number | Name | Description |
|------------|-----------------|-----------------------|
| 1 | DATA | PDM data output |
| 2 | V _{DD} | Power supply |
| 3 | CLOCK | PDM clock input |
| 4 | SELECT | PDM left/right select |
| 5 | GND | Ground |

Footprint and stencil recommendation

7 Footprint and stencil recommendation

The acoustic port hole diameter in the PCB should be larger than the acoustic port hole diameter of the MEMS Microphone to ensure optimal performance. A PCB sound port size of radius 0.4 mm (diameter 0.8mm) is recommended.

The board pad and stencil aperture recommendations shown in **Figure 12** are based on Solder Mask Defined (SMD) pads. The specific design rules of the board manufacturer should be considered for individual design optimizations or adaptations.

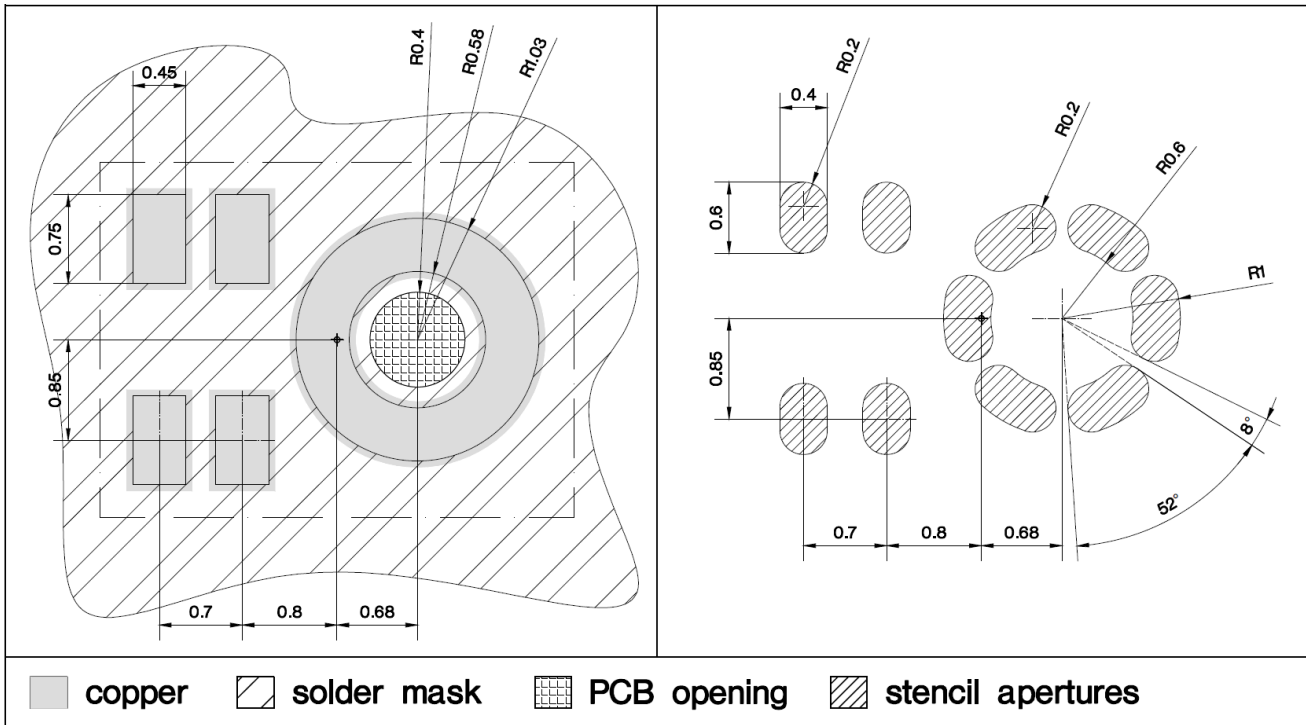

Figure 12 IM69D120 footprint and stencil recommendation

Note: Dimensions are in millimeters unless otherwise specified

Packing

8 Packing

For shipping and assembly the Infineon microphones are packed in product specific tape-and-reel carriers. A detailed drawing of the carrier can be seen in **Figure 13**

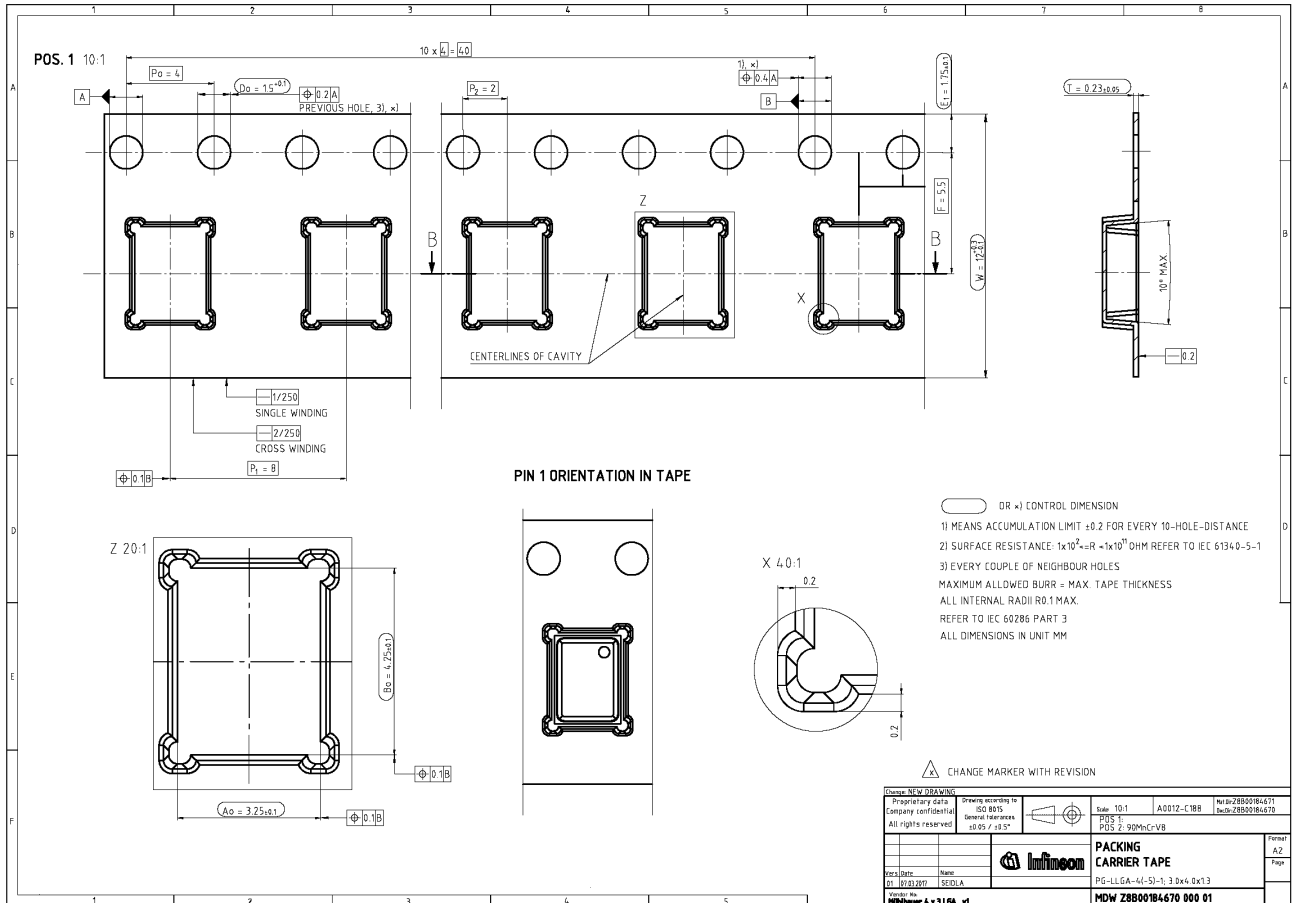

Figure 13 IM69D120 tape dimensions

Note: For further information about Packing, please confer the Packing document which is available on the Infineon Technologies web page or contact your local sales, application, or quality engineer.

Revision history

Revision history

| Document version | Date of release | Description of changes |
|-------------------------|------------------------|-------------------------------|
| 1.0 | 20.12.2017 | Initial datasheet |

Trademarks

All referenced product or service names and trademarks are the property of their respective owners.

Edition 2017-12-20

Published by
Infineon Technologies AG
81726 Munich, Germany

© 2017 Infineon Technologies AG
All Rights Reserved.

Do you have a question about any
aspect of this document?
Email: erratum@infineon.com

Document reference
IFX-tgc1507128354827

IMPORTANT NOTICE

The information given in this document shall in no event be regarded as a guarantee of conditions or characteristics ("Beschaffheitsgarantie").

With respect to any examples, hints or any typical values stated herein and/or any information regarding the application of the product, Infineon Technologies hereby disclaims any and all warranties and liabilities of any kind, including without limitation warranties of non-infringement of intellectual property rights of any third party.

In addition, any information given in this document is subject to customer's compliance with its obligations stated in this document and any applicable legal requirements, norms and standards concerning customer's products and any use of the product of Infineon Technologies in customer's applications.

The data contained in this document is exclusively intended for technically trained staff. It is the responsibility of customer's technical departments to evaluate the suitability of the product for the intended application and the completeness of the product information given in this document with respect to such application.

WARNINGS

Due to technical requirements products may contain dangerous substances. For information on the types in question please contact your nearest Infineon Technologies office.

Except as otherwise explicitly approved by Infineon Technologies in a written document signed by authorized representatives of Infineon Technologies, Infineon Technologies' products may not be used in any applications where a failure of the product or any consequences of the use thereof can reasonably be expected to result in personal injury

Mouser Electronics

Authorized Distributor

Click to View Pricing, Inventory, Delivery & Lifecycle Information:

[Infineon:](#)

[IM69D120V01XTSA1](#)