

■ Typical Specifications

Items	Specifications
Rating (max.)/(min.) (Resistive load)	1mA 5V DC / 50 μ A 3V DC
Contact resistance (Initial / After operating life)	200m Ω max. / 250m Ω max.
Rotational torque	13 \pm 5mN·m
Operating life with load	10,000 cycles (1mA 5V DC)
Voltage proof	100V AC 1minute

■ Product Line

Poles	Positions	Changeover angle	Detent	Location lug	Changeover timing	Soldering	Actuator length (mm)	Minimum order unit (pcs.)		Product No.	Drawing No.
								Japan	Export		
1	10	36°	5	with	Non shorting	For PC board (Reflow)	1.7	1,200	4,800	SRBD150201	1
			7	without						SRBD170401	2
			8	with						SRBD180201	1
			10							SRBD110401	

■ Packing Specifications

Taping

Number of packages (pcs.)			Tape width (mm)	Export package measurements (mm)
1 reel	1 case /Japan	1 case /export packing		
1,200	2,400	4,800	24	428×413×172

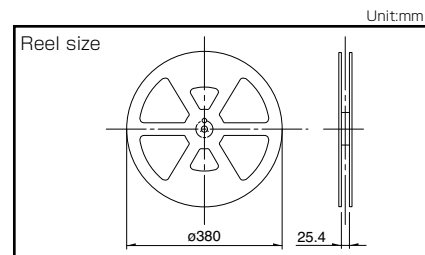

Detector
Slide
Push
Rotary
Power
Dual-In-line Package Type

SRBD Heavy-torque Feel, Low-profile Type

Dimensions

Unit:mm

No.	Style	PC board mounting hole dimensions (Viewed from direction A)
1		
2		

Circuit Diagram (Viewed from Direction A)

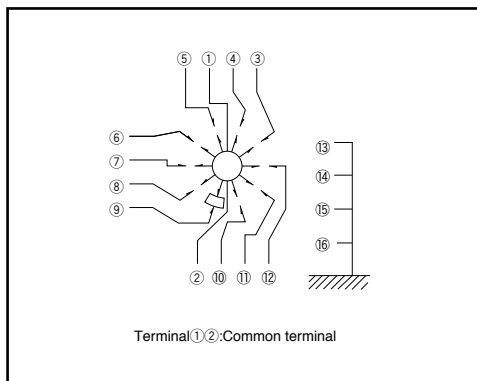













Correspondence Table of Terminal No. and Detent

Position No.	Terminal No.	Detent			
		5	7	8	10
1	③	—	○	—	○
2	④	—	○	○	○
3	⑤	—	○	○	○
4	⑥	○	○	○	○
5	⑦	○	○	○	○
6	⑧	○	○	○	○
7	⑨	○	○	○	○
8	⑩	○	—	○	○
9	⑪	—	—	○	○
10	⑫	—	—	—	○

Rotary Switches

List of Varieties

Series	SRBD	SRBQ		SRBM		SRBV	SRRM	SRRN	
		Insertion	Reflow type	Rotary	Pulse				
Photo									
Angle of throw	36°	40±3°		30±3°	18±3°	30±3°			
Number of poles	1		1, 2		1	1, 2, 3, 4	2, 3, 4		
Rotational torque	13±5mN·m	6±3mN·m 13±5mN·m		40±20mN·m 15±7mN·m		30±15mN·m	80±30mN·m (Shorting) 70±30mN·m (Non shorting)	70±30mN·m	
Dimensions (mm)	W	10		10		16.2	—	—	
	D	11.4		12.4		18.5			
	H	3.5		11		7.5			
Operating temperature range	-25°C to +85°C	-10°C to +60°C		-30°C to +85°C		-10°C to +85°C	-10°C to +60°C	-30°C to +65°C	
Automotive use	—	—		—		—	—	—	
Life cycle									
Rating (max.)/(min.) (Resistive load)	1mA 5V DC 50µA 3V DC	0.1A 16V DC 50µA 3V DC				0.3A 16V DC 50µA 3V DC	0.25A 30V DC 50µA 3V DC	0.15A 12V DC 50µA 3V DC	
Durability	Operating life without load	10,000 cycles 250mΩ max.	10,000 cycles 100mΩ max.		30,000 cycles 100mΩ max.	10,000 cycles 100mΩ max.	10,000 cycles 40mΩ max.	10,000 cycles 70mΩ max.	
	Operating life with load Load: as rating	10,000 cycles 250mΩ max.	10,000 cycles 100mΩ max.	10,000 cycles 150mΩ max.		10,000 cycles 60mΩ max.	10,000 cycles 100mΩ max.		
Electrical performance	Initial contact resistance	200mΩ max.	50mΩ max.				20mΩ max.	50mΩ max.	
	Insulation resistance	100MΩ min. 100V DC					100MΩ min. 500V DC		
	Voltage proof	100V AC for 1minute					500V AC for 1minute		
Mechanical performance	Terminal strength	3N for 1minute	5N for 1minute				10N for 1minute	5N for 1minute	
	Actuator strength	Operating direction	—	—	0.5N·m	—	0.6N·m	1N·m	
		Pulling direction	50N	20N	100N				
	Wobble of actuator	Load at the tip of shaft SRRM, SRBM, SRRN: 5N, SRBQ, SRBV: 1N							
The below table shows for SRRM, SRBM, SRRN				The below table shows for SRBQ		The below table shows for SRBV			
Measuring position from mounting surface		Shaft wobble (max. value)	Applicable mounting dimension	Distance from mounting surface to the tip of shaft	Shaft wobble (max. value)	Measuring position from mounting surface	Shaft wobble (max. value)	Applicable mounting dimension	
10		0.17	15	below 5	0.5	10	0.2	15	
15		0.25	20	above 5 and below 10	0.9	15	0.3	20	
20	0.35	25	above 10 and below 15	1.2	20	0.4	25		
25	0.42	30							
30	0.5	above 35							
Unit:mm									
Environmental performance	Cold	-40°C 500h	-20°C 96h	-40°C 96h	-20°C 96h		-40°C 96h		
	Dry heat	85°C 500h	85°C 96h						
	Damp heat	60°C, 90 to 95%RH 500h	40°C, 90 to 95%RH 96h						
Page	133	135	137	140	142	145			

Rotary Switches Soldering Conditions 148
 Rotary Switches Cautions 149

Example of Reflow Soldering Condition

1. Heating method: Double heating method with infrared heater.
2. Temperature measurement: Thermocouple $\phi 0.1$ to 0.2 CA (K) or CC (T) at soldering portion (copper foil surface). A heat resisting tape should be used for fixed measurement.
3. Temperature profile

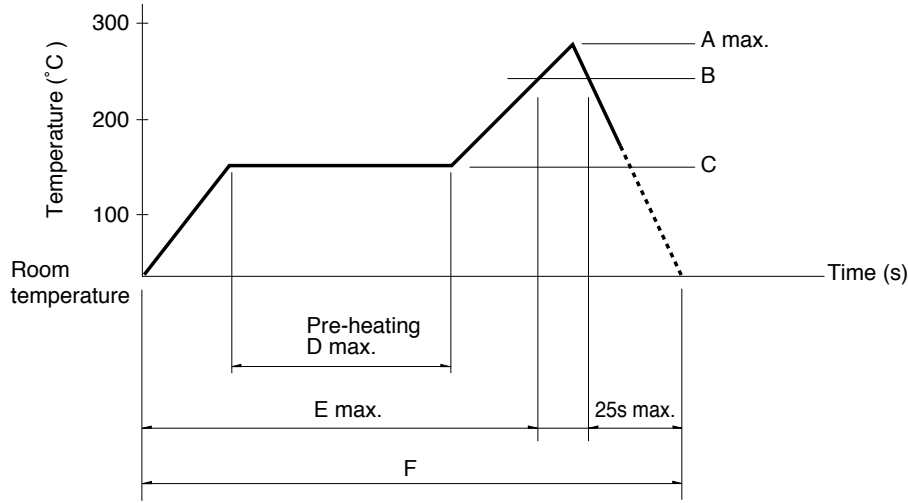

Series (Reflow type)	A (°C) 3s max.	B (°C)	C (°C)	D (s)	E (s)	F (s)
SRBQ	250	200	150±5	80 to 100	—	—

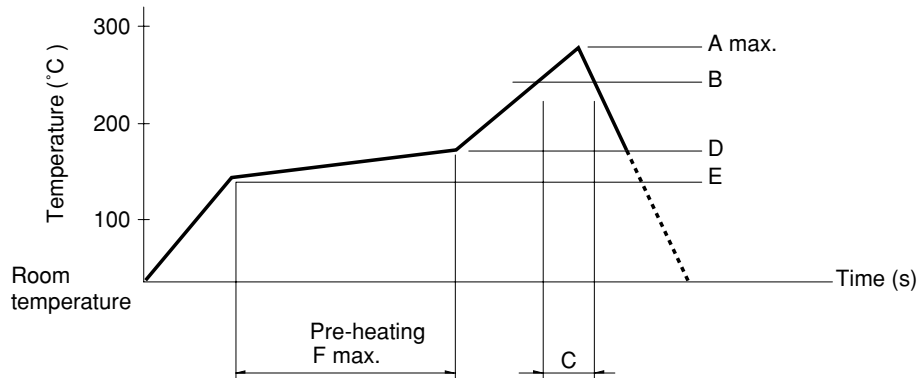

Series (Reflow type)	A (°C) 3s max.	B (°C)	C (s)	D (°C)	E (°C)	F (s)
SRBD	260	230	40	180	150	120

- Notes**
1. The condition mentioned above is the temperature on the mounting surface of a PC board. There are cases where the PC board's temperature greatly differs from that of the switch, depending on the PC board's material, size, thickness, etc. The above-stated conditions shall also apply to switch surface temperatures.
 2. Soldering conditions differ depending on reflow soldering machines. Prior verification of soldering condition is highly recommended.

Reference for Hand Soldering

Series	Soldering temperature	Soldering time
SRBQ, SRBM, SRBV, SRRM, SRRN	350±10°C	3+1/0s
SRBQ (Reflow type)	350±5°C	3s max.

Reference for Dip Soldering

(For PC board terminal types)

Series	Items		Dip soldering	
	Preheating temperature	Preheating time	Soldering temperature	Duration of immersion
SRBM	100°C max.	60s max.	260±5°C	5s max.
SRBV, SRRM, SRRN	—	—	260±5°C	10±1s
SRBQ	—	—	260±5°C	5±1s

Mouser Electronics

Authorized Distributor

Click to View Pricing, Inventory, Delivery & Lifecycle Information:

ALPS:

[SRBD170401](#) [SRBD150201](#) [SRBD110401](#) [SRBD180201](#)