



# WS3A012065K

## Silicon Carbide Schottky Diode

$V_{RRM}$	=	650	V
$I_F (T_C \leq 135^\circ C)$	=	18	A**
$Q_C$	=	36	nC**

### Features

- Zero Reverse Recovery Current
- Zero Forward Recovery Voltage
- Positive Temperature Coefficient on  $V_F$
- Temperature-independent Switching
- 175°C Operating Junction Temperature

### Benefits

- Replace Bipolar with Unipolar Device
- Reduction of Heat Sink Size
- Parallel Devices Without Thermal Runaway
- Essentially No Switching Losses

### Applications

- Switch Mode Power Supplies
- Power Factor Correction
- Motor drive, PV Inverter, Wind Power Station

### Package



Part Number	Package	Marking
WS3A012065K	TO-247-3	WS3A012065K

### Maximum Ratings

Symbol	Parameter	Value	Unit	Test Conditions	Note
$V_{RRM}$	Repetitive Peak Reverse Voltage	650	V	$T_C = 25^\circ C$	
$V_{RSM}$	Surge Peak Reverse Voltage	650	V	$T_C = 25^\circ C$	
$V_R$	DC Blocking Voltage	650	V	$T_C = 25^\circ C$	
$I_F$	Forward Current (Per leg/Device)	19/38 9/18 6/12	A	$T_C \leq 25^\circ C$ $T_C \leq 135^\circ C$ $T_C \leq 157^\circ C$	
$I_{FSM}$	Non-Repetitive Forward Surge Current	60*	A	$T_C = 25^\circ C, t_p = 8.3ms, \text{Half Sine Wave}$	
$P_{tot}$	Power Dissipation (Per leg/Device)	93/ 186	W	$T_C = 25^\circ C$	Fig.3
$T_C$	Maximum Case Temperature	157	$^\circ C$		
$T_J, T_{STG}$	Operating Junction and Storage Temperature	-55 to 175	$^\circ C$		
	TO-247 Mounting Torque	1	Nm	M3 Screw	

\*Per Leg, \*\*Per Device

## Electrical Characteristics (Per Leg)

Symbol	Parameter	Typ.	Max.	Unit	Test Conditions	Note
$V_F$	Forward Voltage	1.4 1.75	1.65 2.3	V	$I_F = 6A, T_J = 25^\circ C$ $I_F = 6A, T_J = 175^\circ C$	Fig.1
$I_R$	Reverse Current	1 5	20 100	$\mu A$	$V_R = 650V, T_J = 25^\circ C$ $V_R = 650V, T_J = 175^\circ C$	Fig.2
C	Total Capacitance	300 34 30	/	pF	$V_R = 0V, T_J = 25^\circ C, f = 1MHz$ $V_R = 200V, T_J = 25^\circ C, f = 1MHz$ $V_R = 400V, T_J = 25^\circ C, f = 1MHz$	Fig.5
$Q_C$	Total Capacitive Charge	18	/	nC	$V_R = 650V, I_F = 6A$ $di/dt = 200A/\mu s, T_J = 25^\circ C$	Fig.4

## Thermal Characteristics

Symbol	Parameter	Typ.	Unit	Note
$R_{\theta JC}$	Thermal Resistance from Junction to Case	1.6* 0.8**	$^\circ C/W$	Fig.6
$R_{\theta JA}$	Thermal Resistance from Junction to Ambient	80	$^\circ C/W$	
$T_{sold}$	Soldering Temperature	260	$^\circ C$	

\*Per Leg, \*\*Per Device

## Typical Performance (Per Leg)

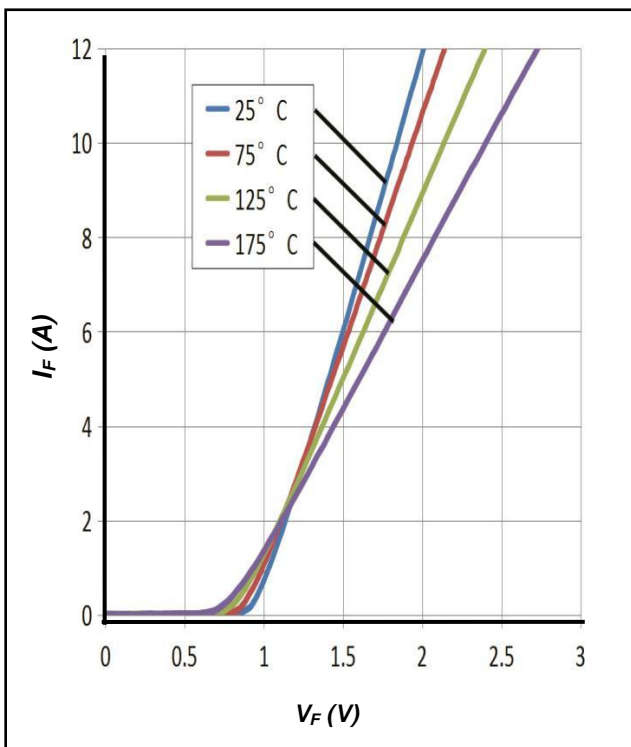

Figure 1. Forward Characteristics

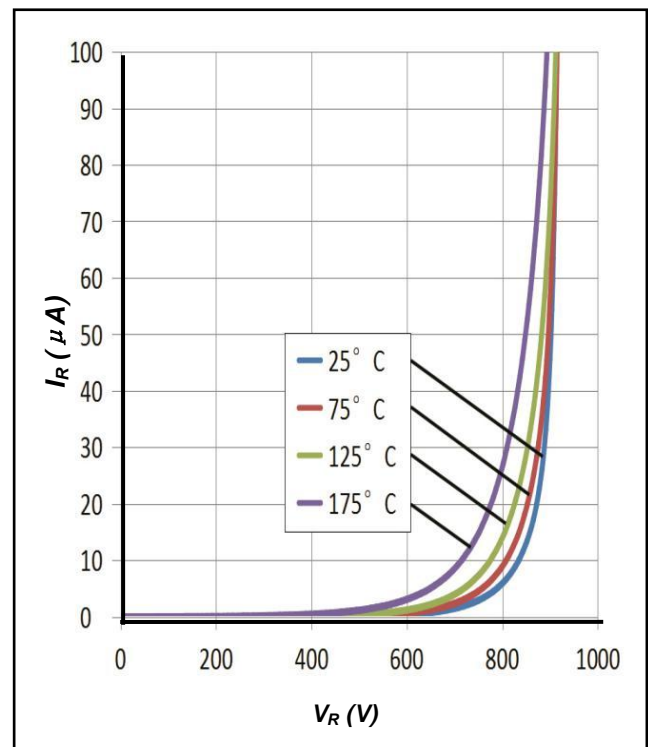

Figure 2. Reverse Characteristics

### Typical Performance (Per Leg)

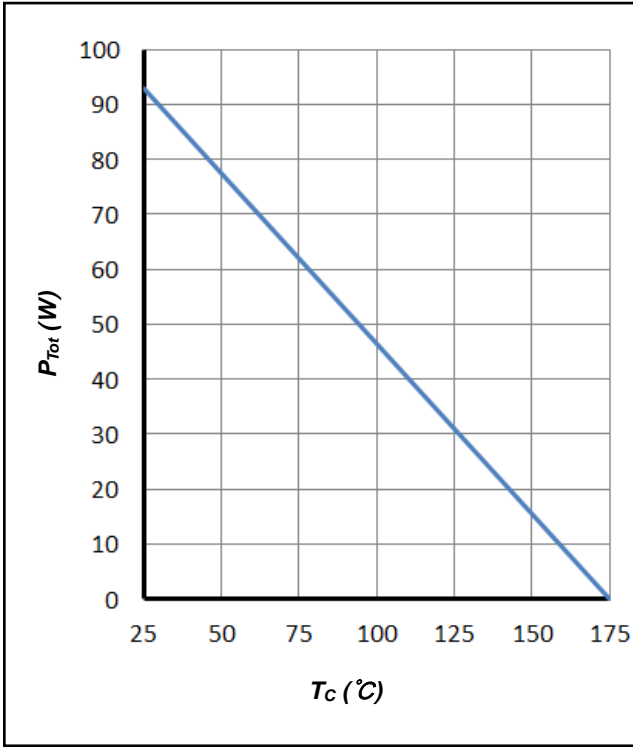

Figure 3. Power Derating

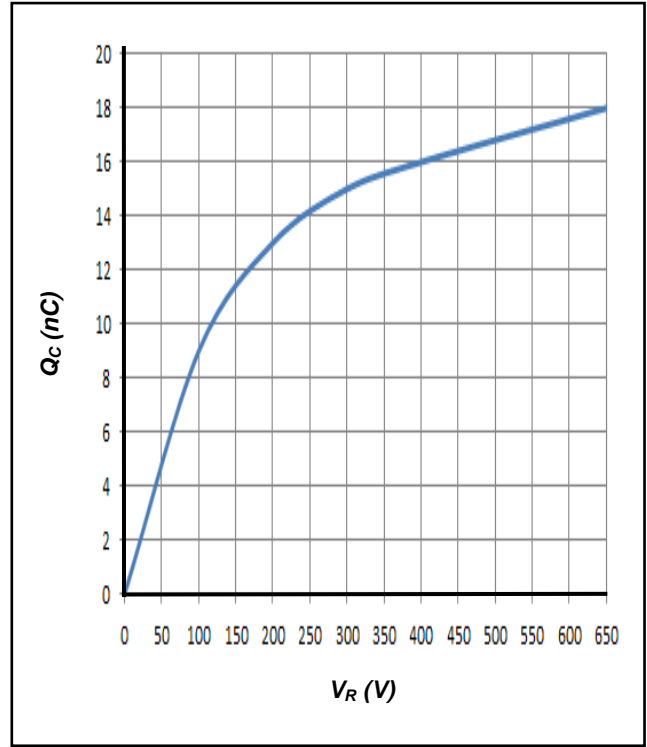

Figure 4. Total Capacitive Charge vs. Reverse Voltage

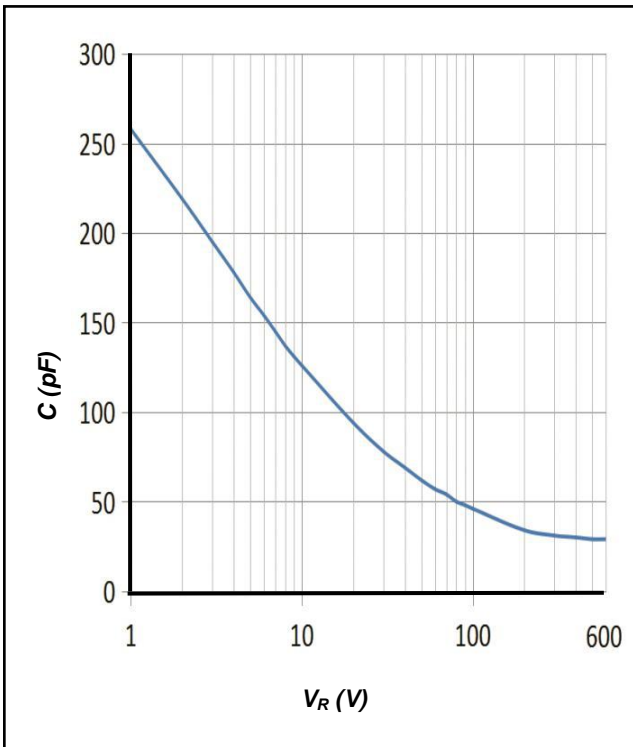

Figure 5. Total Capacitance vs. Reverse Voltage

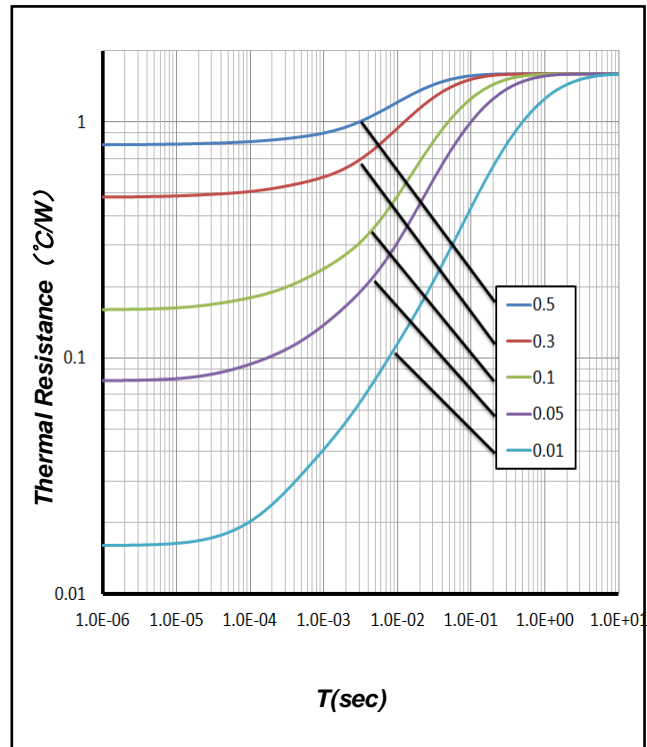
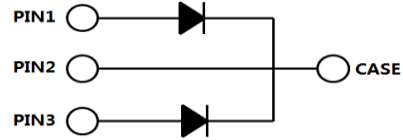
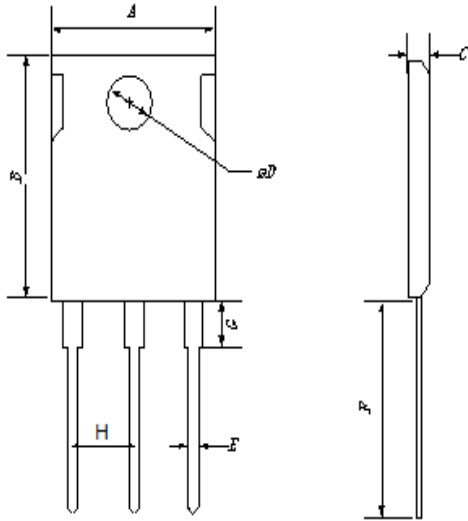

Figure 6. Transient Thermal Impedance

## Package Dimensions

Package TO-247-3



Symbol	Min. (mm)	Typ. (mm)	Max. (mm)
A	14.18	15.75	17.33
B	18.45	20.5	22.55
C	4.50	5.00	5.50
D	3.15	3.50	3.85
E	1.08	1.20	1.32
F	18.27	20.30	22.33
G	4.21	4.68	5.15
H	4.91	5.46	6.01

## Simplified Diode Model (Per Leg)

Equivalent IV Curve for Model

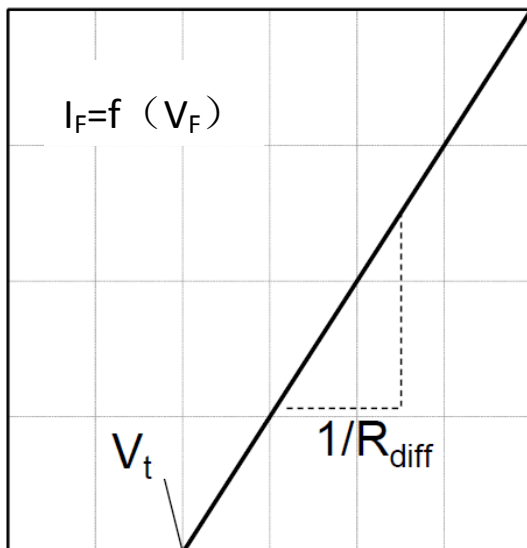

Mathematical Equation

$$V_F = V_t + I_F \times R_{diff}$$

$$V_t = -0.0014 \times T_j + 1.002 \text{ [V]}$$

$$R_{diff} = 2.0 \times 10^{-6} \times T_j^2 + 1.5 \times 10^{-4} \times T_j + 0.082 \text{ [\Omega]}$$

Note:

$T_j$  = Diode Junction Temperature In Degrees Celsius,  
valid from 25°C to 175°C

$I_F$  = Forward Current

Less than 12A