

FEATURES

- **Maximum Output current: 0.1A**
- **Output Voltage: 5V**
- **Thermal Overload Protection**
- **2%Output Voltage Accuracy**

PIN CONNECTION

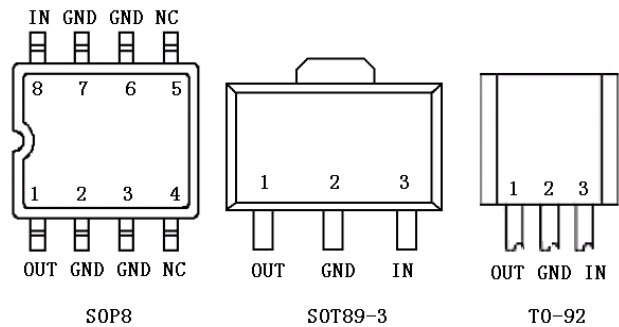

Absolute Maximum Ratings (Ta=25°C)

Characteristics	Symbol	Value	Unit
Input Voltage	V_i	35	V
Operating Junction Temperature Range	T_j	-40 ~ +125	°C
Power Dissipation	P_d	T092	625
		SOT89-3	750
		SOP8	500*
Operating Temperature Range	T_{opr}	-40 ~ +85	°C
Storage Temperature Range	T_{stg}	-40 ~ +150	°C

ELECTRICAL CHARACTERISTICS

(unless otherwise noted, $V_i=10V, I_o=40mA, -30 < T_j < 85^\circ C, C_1=0.33\mu F, C_o=0.1\mu F$) (Note1)

Characteristics	Test conditions	Symbol	Min	Typ	Max	Unit
Output Voltage	$T_j=25^\circ C$	V_o	4.9	5	5.1	V
	$7V \leq V_i \leq 20V; I_o=1mA \sim 40mA$		4.8		5.2	V
	$7V \leq V_i \leq V_{max}; I_o=1mA \sim 70mA$		4.8		5.2	V (Note2)
Load Regulation	$T_j=25^\circ C; I_o=1mA \sim 100mA$	ΔV_o		11	60	mV
	$T_j=25^\circ C; I_o=1mA \sim 40mA$			5	6	mV
Line Regulation	$T_j=25^\circ C; 7V \leq V_i \leq 20V$	ΔV_o		8	150	mV
	$T_j=25^\circ C; 8V \leq V_i \leq 20V$			6	100	mV
Quiescent Current		I_q		2	5.5	mA
Quiescent Current Change	$8V \leq V_i \leq 20V$	ΔI_q			1.5	mA
	$1mA \leq I_o \leq 40mA$				0.2	mA
Output Noise Voltage	$10Hz \leq f \leq 100kHz$	V_N		40		μV
Temperature Coefficient of V_o	$I_o=5mA$	$\Delta V_o / \Delta T$		-0.65		mV/°C
Ripple Rejection	$10V \leq V_i \leq 20V; f=120Hz; T_j=25^\circ C$	RR	41	48		dB
Dropout Voltage	$T_j=25^\circ C$	V_d		1.7		V

Note 1: The Maximum steady state usable output current and input voltage are very dependent on the heating sinking and/or lead temperature length of the package. The date above represent pulse test conditions with junction temperatures as indicated at the initiation of test.

Note 2: Power dissipation $T_o-92 < 0.625W, SOT-89 < 0.75W, SOP8 < 0.5W$

APPLICATION CIRCUIT

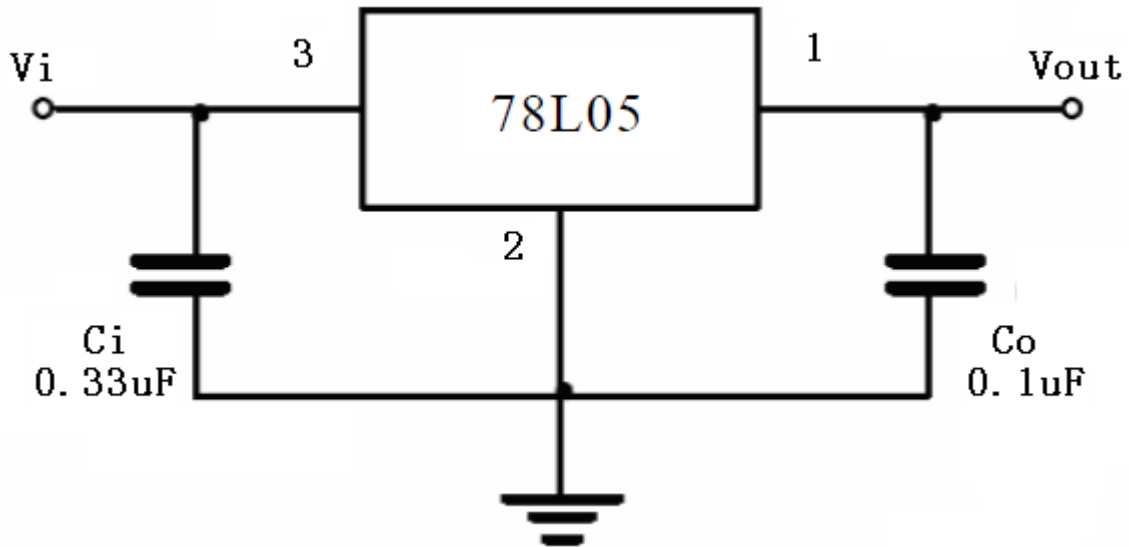

*Bypass capacitors are recommended for optimum stability and transient response and should be located as close as Possible to the regulators.

OUTLINE DRAWING

