



ORIENT

Photocoupler

Product Data Sheet

Name: OR-10XX

Customer: _____

Date: _____

Add: Block A 3rd Floor No.4 Building Tian An Cyber Park Huang Ge Rd, Long Gang Dist, Shenzhen, Guangdong, 518172

Web: www.orient-opto.com

1. Features

- (1) Current transfer ratio
 (CTR: 50~600% at $I_F = 5\text{mA}$, $V_{CE} = 5\text{V}$)
 (CTR: 63~320% at $I_F = 10\text{mA}$, $V_{CE} = 5\text{V}$)
- (2) High input-output isolation voltage ($V_{iso} = 5,000\text{Vrms}$)
- (3) High collector-emitter voltage ($V_{CEO} = 70\text{V}$)
- (4) Temperature range $-55\text{ }^\circ\text{C}$ to $110\text{ }^\circ\text{C}$
- (5) Creepage distance > 8mm
- (6) Employs double transfer mold technology
- (7) Long Mini-flat package : 2.3mm profile :OR-10XX series

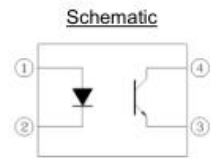
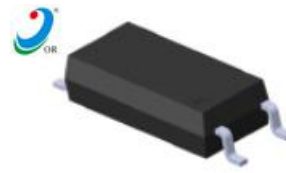

Pin Configuration
 1. Anode
 2. Cathode
 3. Emitter
 4. Collector

2. Description

The OR-10XX series devices consist of an infrared emitting diode, optically coupled to a phototransistor detector. They are packaged in a 4-pin SOP package.

3.Applications

- (1) Programmable controllers
- (2) System appliances, measuring instruments
- (3) Telecommunication equipments
- (4) Home appliances, such as fan heaters, etc.
- (5) Signal transmission between circuits of different potentials and impedances

4. Absolute Maximum Ratings (Ta=25°C)

Parameter		Symbol	Rated Value	Unit
Input	Forward Current	I_F	60	mA
	Junction Temperature	T_J	125	$^\circ\text{C}$
	Reverse Voltage	V_R	6	V
	Consume Power	P	100	mW
Output	Collector and emitter Voltage	V_{CEO}	80	V
	Emitter and collector Voltage	V_{ECO}	7	
	Collector Current	I_C	50	mA
	Consume Power	P_C	150	mW
Total Consume Power		P_{tot}	250	mW
*1	Insulation Voltage	V_{iso}	5000	Vrms
Working Temperature		T_{opr}	-55 to + 110	$^\circ\text{C}$
Deposit Temperature		T_{stg}	-55 to + 125	
*2	Soldering Temperature	T_{sol}	260	

Notes

*1 AC for 1 minute, R.H.= 40 ~ 60% R.H. In this test, pins 1, 2 are shorted together, and pins 3, 4 are shorted together.

* 2 For 10 seconds

5. Electrical Optical Characteristics at Ta=25°C

Parameter		Symbol	Condition	Min	Typ.*	Max	Unit
Input	Forward Current	V_F	$I_F=50mA$	---	1.25	1.6	V
	Reverse Voltage	I_R	$V_R=4V$	---	---	10	μA
	Collector capacitance	C_t	$V=0, f=1MHz$	---	50	---	pF
Output	Collector to emitter Current	I_{CEO}	$V_{CE}=20V,$ $I_F=0mA$	---	10	100	nA
	Collector and Emitter attenuation Voltage	BV_{CEO}	$I_C=1mA$ $I_F=0mA$	80	---	---	V
	Emitter and Collector attenuation Voltage	BV_{ECO}	$I_E=0.1mA$ $I_F=0mA$	7	---	---	V
Transforming Characteristics	*1 Current conversion ratio	CTR	$I_F=5mA$ $V_{CE}=5V$	50	---	600	%
	Collector Current	I_C		2.5	---	30	mA
	Collector and Emitter Saturation Voltage	$V_{CE(sat)}$	$I_F=10mA$ $I_C=1mA$	---	---	0.3	V
	Insulation Impedance	R_{iso}	DC500V 40~60%R.H.	10^{12}	---	---	Ω
	Floating Capacitance	C_f	$V=0, f=1MHz$	---	0.3	---	pF
	Response Time	t_r	$V_{CC}=5V,$ $I_C=2mA$ $R_L=100\Omega$	---	3	18	μs
	Descend Time	t_f		---	4.7	18	μs

*1 Current Conversion Ratio = $I_C / I_F \times 100\%$, CTR Tolerance: $\pm 3\%$.

6. Rank Table of Current Transfer Ratio

CTR Rank	Min.	Typ.	Max.	Unit	Condition
OR-1000	50	—	600	%	IF=5mA, V _{CE} =5V, Ta=25°C
OR-1001	100	—	160		
OR-1004	100	—	200		
OR-1005	50	—	150		
OR-1006	100	—	300		
OR-1007	80	—	160		
OR-1008	130	—	260		
OR-1009	200	—	400		
OR-1010	150	—	300		
OR-1019	250	—	500		
OR-1020	300	—	450		
OR-1002	22	—	—	%	IF=1mA, V _{CE} =5V, Ta=25°C
OR-1003	34	—	—		
OR-1014	56	—	—		
OR-1015	63	—	125		
OR-1018	100	—	200		
OR-1002	63	—	125	%	IF=10mA, V _{CE} =5V, Ta=25°C
OR-1003	100	—	200		
OR-1014	160	—	320		

7.Naming Rule

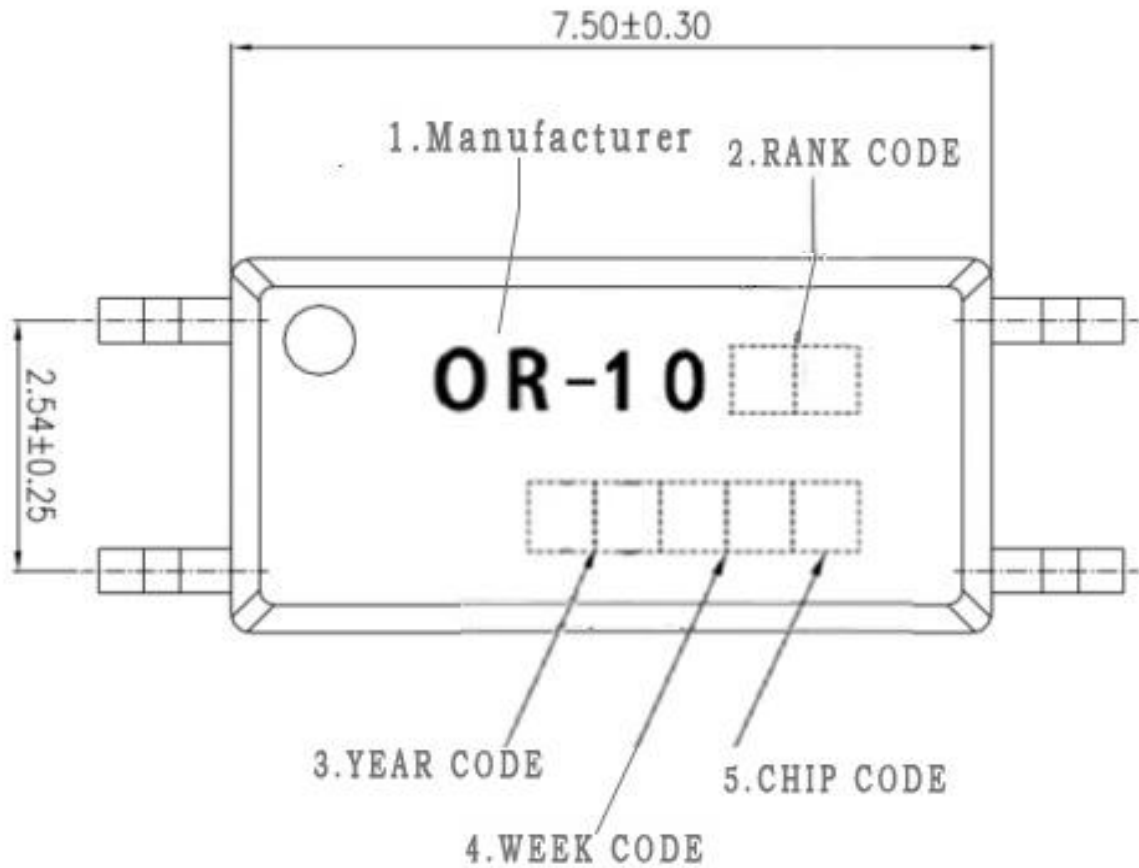

注:

- (1)OR denotes Shenzhen Orient Tech Ltd . Co ., Ltd.
- (2) denotes Rank Code.
- (3) denotes Year code.
- (4) denotes Week code.
- (5) denotes Chip Code
- (6) OR-10 denotes Device Part Number.
- (7) Unit:mm

8. Package Dimension

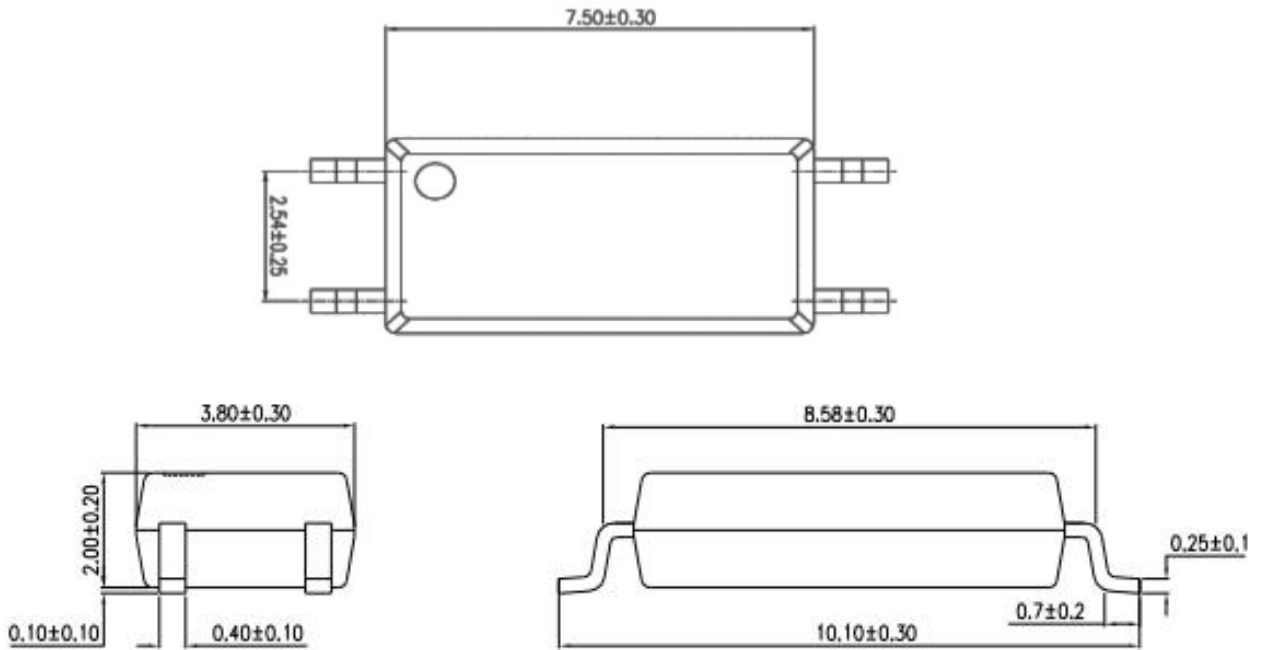

9. RECOMMENDED FOOT PRINT PATTERNS (MOUNT PAD)

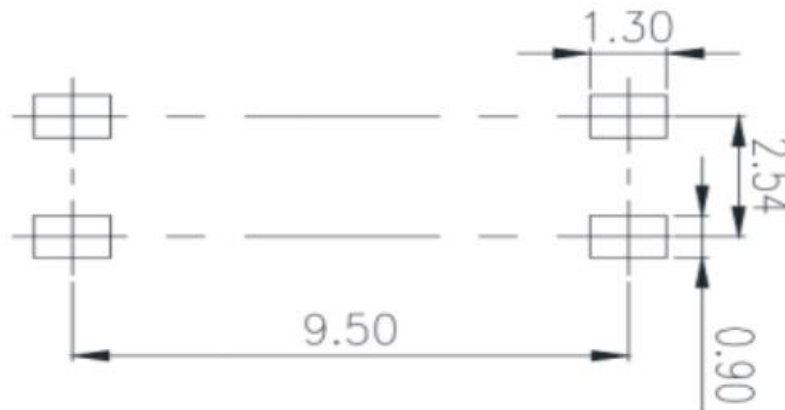

Unit:mm

10. Taping Dimensions

(1) OR-10XX-TP

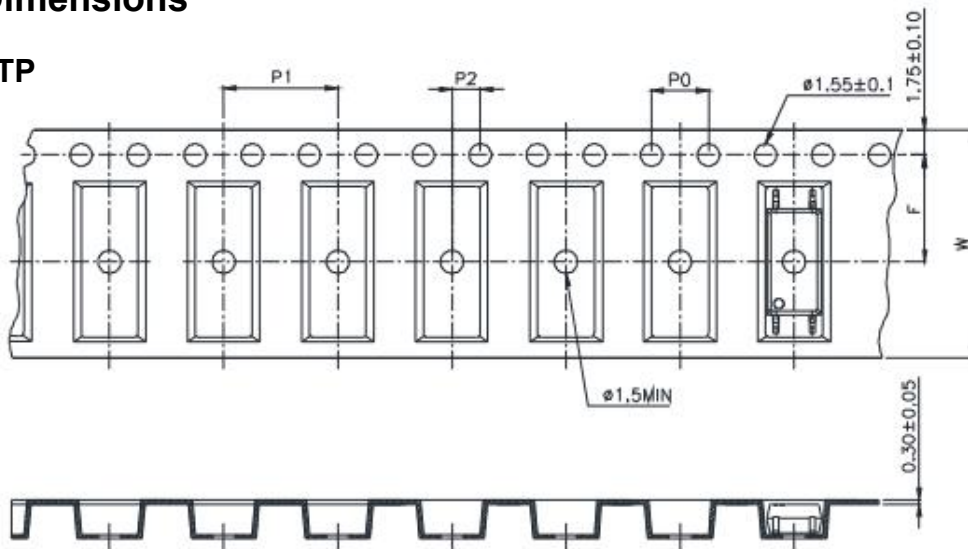

(2) OR-10XX-TP1

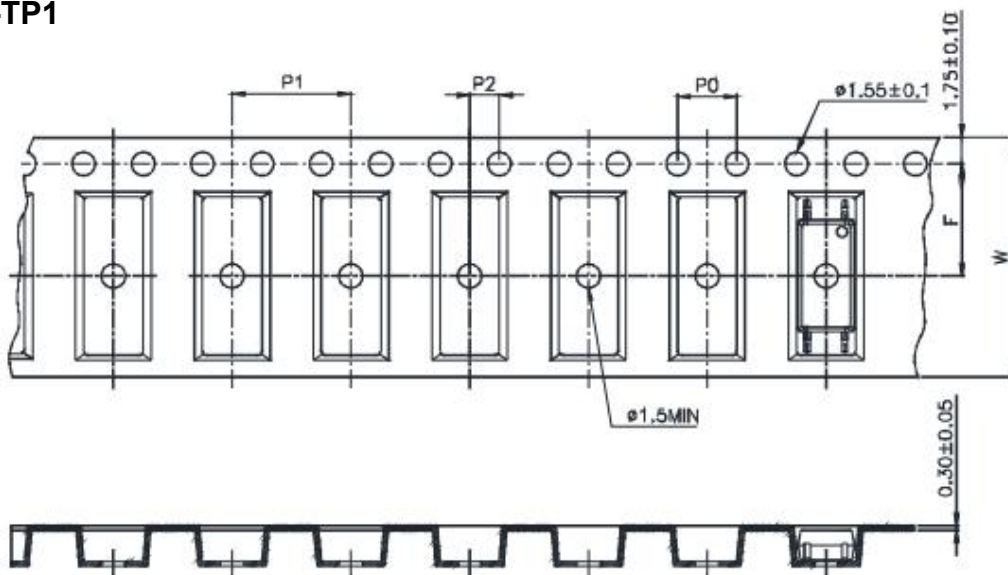

Description	Symbol	Dimension in mm (inch)
Tape wide	W	16±0.3 (0.63)
Pitch of sprocket holes	P ₀	4±0.3 (0.15)
Distance of compartment	F	7.5±0.1 (0.295)
	P ₂	2±0.1 (0.079)
Distance of compartment to compartment	P ₁	8±0.1 (0.315)

Package Type	OR-10XX series(TP/TP1)
Quantities(pcs)	3000

11. Temperature Profile Of Soldering

(1).IR Reflow soldering (JEDEC-STD-020C compliant)

One time soldering reflow is recommended within the condition of temperature and time profile shown below. Do not solder more than three times.

Profile item	Conditions
Preheat	
- Temperature Min (T_{Smin})	150°C
- Temperature Max (T_{Smax})	200°C
- Time (min to max) (t_s)	90±30 sec
Soldering zone	
- Temperature (T_L)	217°C
- Time (t_L)	60 sec
Peak Temperature(T_P)	260°C
Ramp-up rate	3°C / sec max.
Ramp-down rate	3~6°C / sec

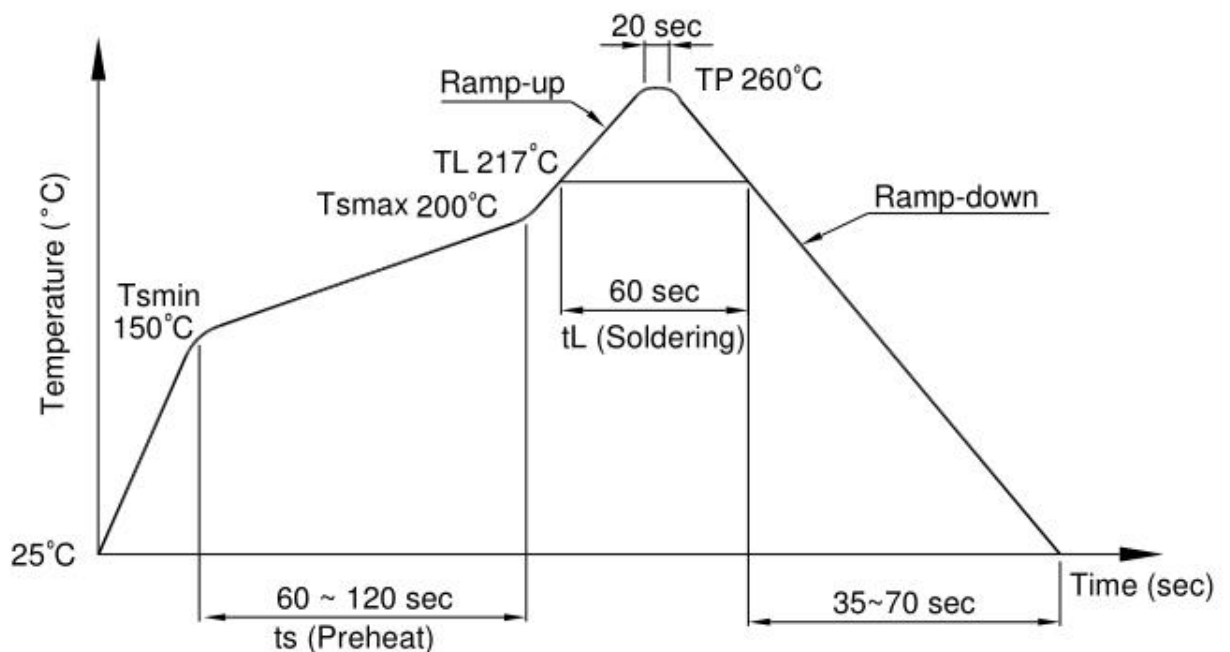

(2).Wave soldering (JEDEC22A111 compliant)

One time soldering is recommended within the condition of temperature.

Temperature	260+0/-5°C
Time	10 sec
Preheat temperature	25 to 140°C
Preheat time	30 to 80 sec

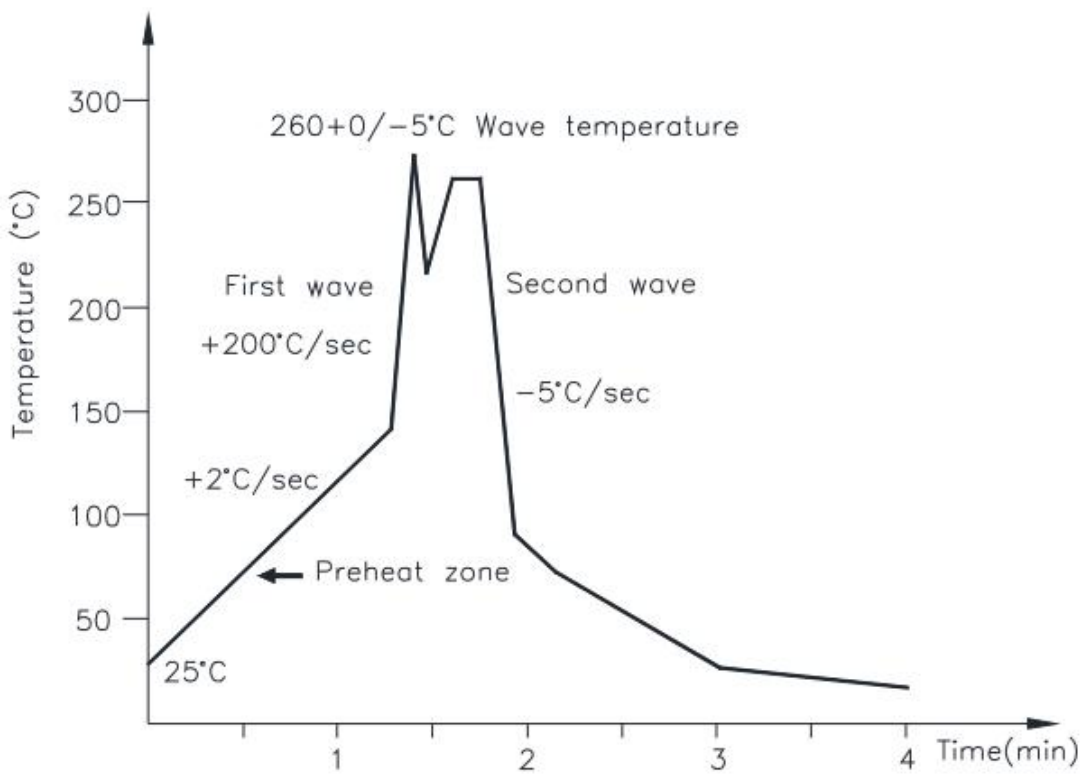

(3).Hand soldering by soldering iron

Allow single lead soldering in every single process. One time soldering is recommended.

Temperature	380+0/-5°C
Time	3 sec max

12.Characteristics Curves

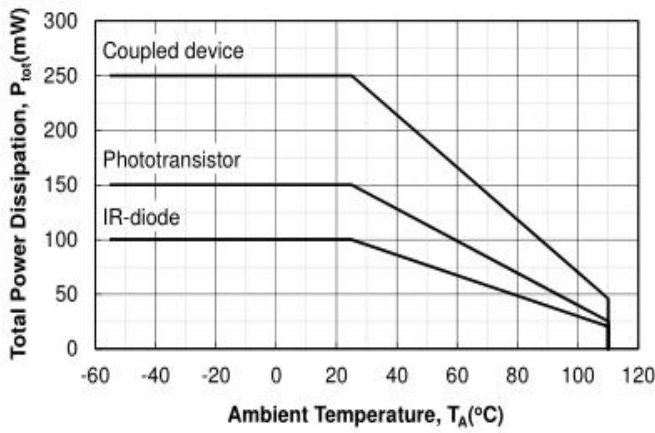

Figure 1. P_{tot} vs. T_A

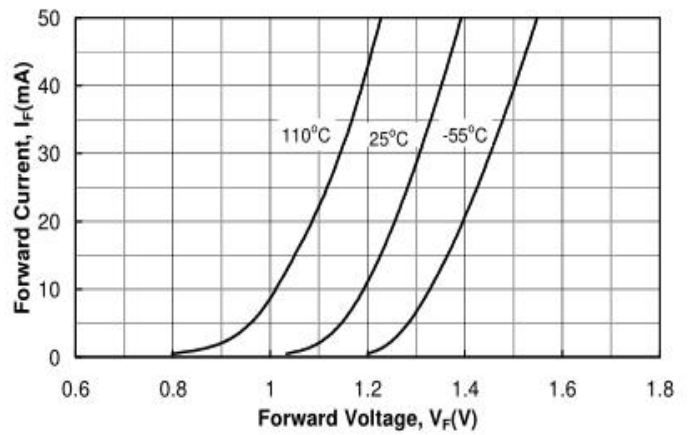

Figure 4. I_F vs. V_F

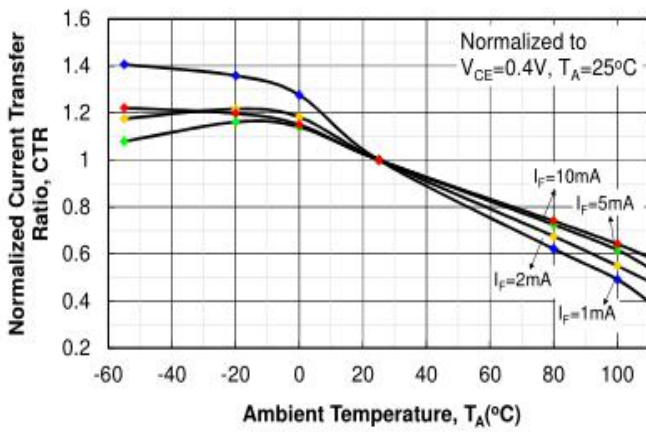

Figure 2. Saturated Normalized CTR vs. T_A

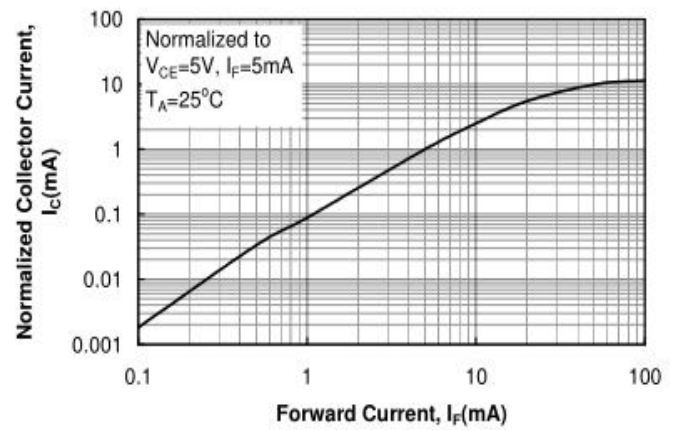

Figure 5. Normalized I_C vs. I_F

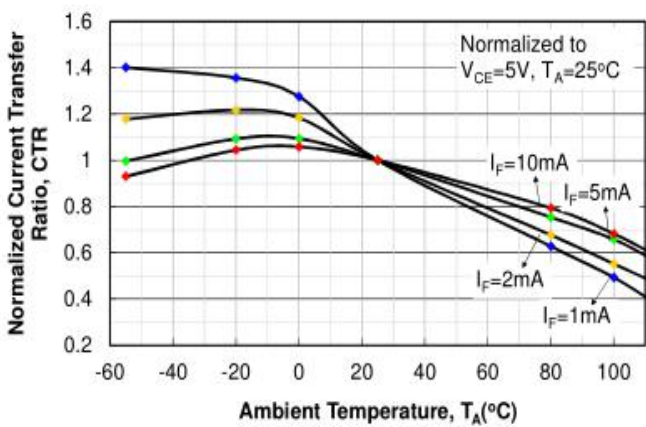

Figure 3. Non-saturated Normalized CTR vs. T_A

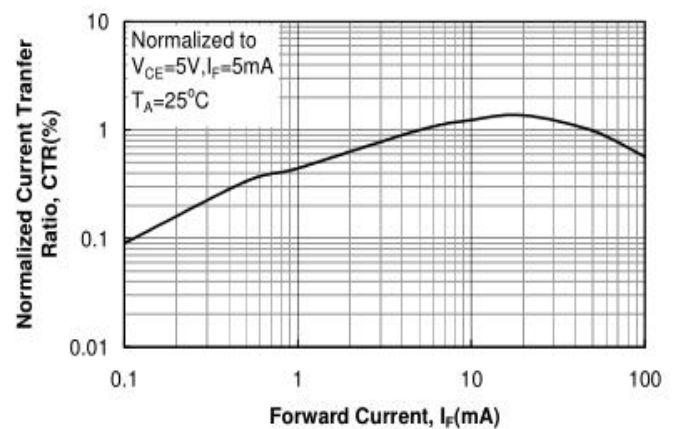

Figure 6. Normalized CTR vs. I_F

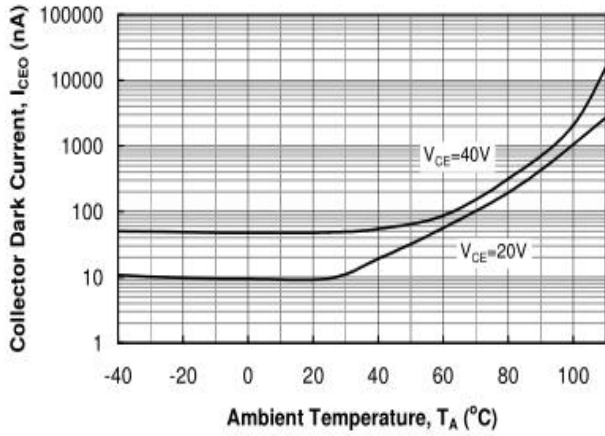

Figure 7. I_{CEO} vs. T_A

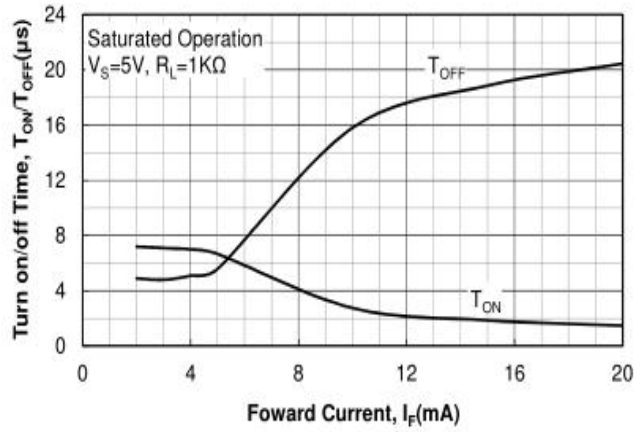

Figure 10. T_{ON} / T_{OFF} vs. I_F

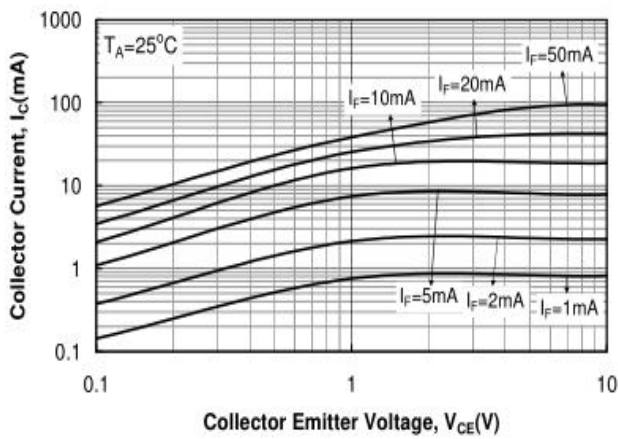

Figure 8. I_C vs. V_{CE}

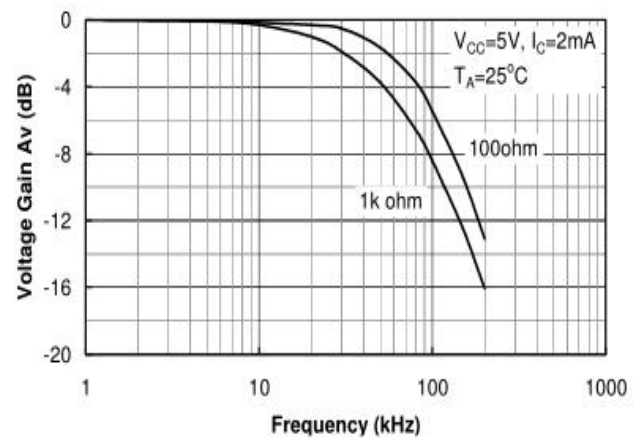

Figure 11. Frequency Response

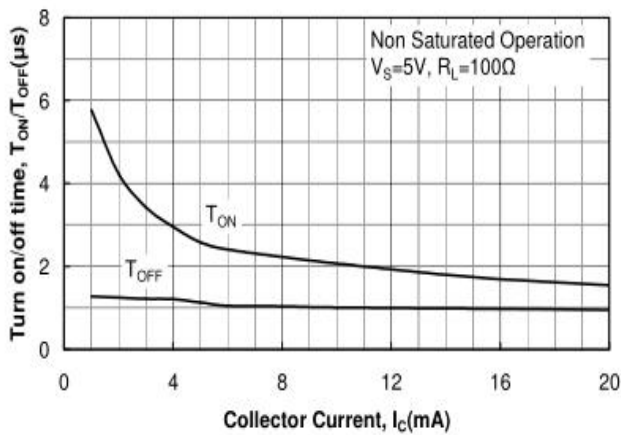

Figure 9. T_{ON} / T_{OFF} vs. I_C